

Global Network



■ SALES & MARKETING

17-2 Jamwon-Dong, Seocho-Gu, Seoul 137-902, Korea
Tel: +82-2-544-1351(Ext. 316, 314) Fax: +82-2-517-7183
E-mail : mspak71@amotech.co.kr ; hjmun@amotech.co.kr

■ FACILITY

5B 1L, 617 Namchon-Dong, Namdong-Gu, Incheon 405-846, Korea
Tel: +82-32-821-0363 Fax: +82-32-811-0283

Global Sales Network

U.S.A. Sales Office

1400 N. Harbor Blvd. Suite#565, Fullerton,
CA 92835, USA
Tel : +1 714 578 5723
Fax : +1 714 578 5724
E-mail : eunice@amotechusa.com

Europe Sales Office

Suite 20, Trinity House, Heather Drive,
Wembley, HA0 1SU, UK
Tel : +44 208 9001 021
Fax : +44 208 9001 844
E-mail : mkcho@amotecheurope.com

Singapore Sales Office

2 International Business Park, #10-11,
the Strategy Tower 1, Singapore
Tel : +65 6568 4105
Fax : +65 6316 1769

Taiwan Sales Office

8F., No.117, Mincyuan Rd., Sindian City,
Taipei County 231, Taiwan (R.O.C.)
Tel: +886-2-8776-2654
Fax: +886-2-8667-1677
E-mail : ericashih@amotech.co.kr

China

Shanghai Office

Rm, 706-707, Green Land Commercial,
No. 1258, Yu Yuan Rd., Shanghai, China
Tel : +86 21 6213 0253
Fax : +86 21 6210 4091
E-mail : vicky_lee@amotech.com.cn

Shenzhen Office

Rm, 202, 2nd Floor, North Block of
Cangsong Building, 6th Tairan Road,
Futian District, Shenzhen, China
Tel : +86 755 8384 3182
Fax : + 86 755 8384 3436
E-mail : shirzh@amotech.com.cn

Beijing Office

Rm.726 Goldland Mansion, No. 1088,
LiangMaQiao Rd., Chaoyang District,
Beijing, China
Tel : +86 10 6464 0942
Fax : +86 10 6460 0418
E-mail : anne@amotech.com.cn

Xiamen Office

Rm.821 SOHO Building No.619,
South Hubin Rd., Xiamen, China
Tel : +86 592 5067 160
Fax : +86 592 5067 160
E-mail : jane@amotech.com.cn



AMOTECH Co., Ltd.

HOME APPLIANCES & MOBILE EMI/ESD PRODUCTS

ESD Suppressor

- Chip Varistor
- EMI/ESD Filter



Advanced Material On **TECH**nology

EMC PRODUCTS

● HIGH SPEED ESD SOLUTION

ASES Series (0402, 0603) / Single Type ESD Suppressor	4P
AMES Series (4-element) / Single Type ESD Suppressor	6P
ADUC Series (0402, 0603) / Ultra Low Capacitance Multi-Channel ESD Suppressor	10P

● GENERAL ESD SOLUTION

SF, SR Series (0402) / Newly Upgraded ESD Solution Series	14P
AVLC Series (0201) / Compact size & Chip Varistor	17P
AVL, AVLC Series / High Power, General Varistor	20P
AVNC Series (0603, 0805) (4-element) / General Array	22P
AVSC Series (0504, 0805) (4-element) / Compact Array (Space Saved)	24P

● EMI / ESD SOLUTION

AMLV 0603 (4-element) / L-C Type EMI-ESD Filter	28P
AVRC Series (0603, 0805) (4-element) / R-C Type	31P
AVRC Series (0504) (2-element) / R-C Type	37P
AVFC Series (0603, 0805) (4-element) / Feed-Thru Type	40P
AVFC Series (0504) (2-element) / Feed-Thru Type	43P

● Tape and Reel Specification	46P
● Soldering Recommendation	47P
● Terminology	48P
● Selection Guidelines & Application Field	50P
● Applications	51P

NOTE

※ customized properties are available upon request.

*1 Insulated Resistance after soldering is 10 MΩ min. [Reflow soldering condition] Temperature profile : 260°C max. , 20 sec.

PB free Solder paste : Tamura (Japan) TLF-204-93S, Measurement shall be made 1 hour after soldering.



Advanced **M**aterial **O**n **T**ECHnology

HIGH SPEED ESD SOLUTION

ASES Series (0402, 0603) / Single Type ESD Suppressor

AMES Series (4-element) / Single Type ESD Suppressor

ADUC Series (0402, 0603) / Ultra Low Capacitance Multi-Channel ESD Suppressor

Overview

ESD-Suppressor is specially designed to protect sensitive electronics from the threat of the electrostatic discharge (ESD). The product reacts almost instantly to the transient voltage and effectively clamps it to the low voltage for the duration of the ESD transient. The product uses voltage variable polymers that inherently produce low capacitance and very low leakage current. Thus the device is virtually invisible to the circuit during normal operational mode. It is especially transparent to the high-speed digital circuits due to the high off-state impedance and low capacitance are not distorted or disrupted as shown by extensive testing. Using the ESD-Suppressor ESD protection, devices maintain signal integrity of highspeed data signals while protecting the circuit from ESD. The nature of the material creates a bidirectional part, which means that only one device per surge path is required to provide complete ESD protection regardless of the surge polarity.



Features

- 0402inch/1005mm size
- IEC 61000-4-2 Level4
- Ultra low capacitance (0.2pF typ.)
- Very low leakage current
- Fast response time
- Bi-directional
- Surface mount

Application

- High Speed Data Ports (USB 2.0, IEEE 1394 , HDMI/DVI)
- Computers & Peripherals (D-TV, Settop Box, DVD Player, Note book, DSC, and Cell phone)

Equivalent Circuit

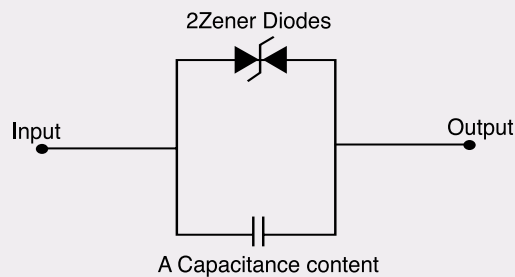

Ordering Information

ASES **12** **U** **02** **0R2**
 ① ② ③ ④ ⑤

① **Series Name**

ASES : Amotech Single type ESD Suppressor

② **Maximum continuous working voltage** : 12 : 12V

③ **Capacitance group** : **U** : Ultra low capacitance

④ **Chip Size** : **02** : 1.0 x 0.5 mm **03** : 1.6 x 0.8 m

⑤ **Typical Capacitance** : **0R2** : 0.2 pF

Electrical Characteristics

Part No.	Rated Voltage Vdc ⁽¹⁾	Clamping Voltage ¹ (Vc_ESD)	Trigger Voltage ² (Vt)	Capacitance (Cp, @ 1MHz)	Leakage Current (IL, @ 12Vdc)	ESD Capability @ IEC61000-4-2 Contact, Air discharge	ESD Pulse Withstand ¹	Operating Temperature
unit	(V)	(V)	(V)	(pF)	(nA)	(KV)		(°C)

0402 (1005) Size

ASES 12U 02 0R2	12 typ	65 typ, 100 max	100 typ	0.2 typ, 0.3 max.	0.1 typ	8 typ, 15 typ.	>1,000 typ.	-40 to +85
-----------------	--------	-----------------	---------	-------------------	---------	----------------	-------------	------------

0603 (1608) Size

ASES 12U 03 0R2	12 typ	65 typ, 100 max	100 typ	0.2 typ, 0.3 max.	0.1 typ	8 typ, 15 typ.	>1,000 typ.	-40 to +85
-----------------	--------	-----------------	---------	-------------------	---------	----------------	-------------	------------

⁽¹⁾Maximum continuous DC working voltage

Dimension Specification (single type)

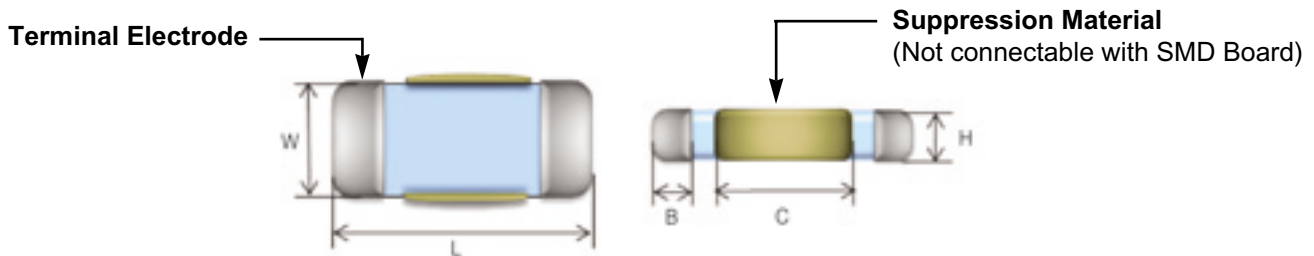

Symbol	L	W	H	B	C
ASES 12U 02 0R2	1.0 ± 0.1	0.5 ± 0.1	0.30 ± 0.05	0.15 ± 0.05	0.55 max
ASES 12U 03 0R2	1.6 ± 0.1	0.8 ± 0.1	0.4 ± 0.05	0.2 ± 0.1	0.55 max

(mm)

Solder Pad Layout (single type)

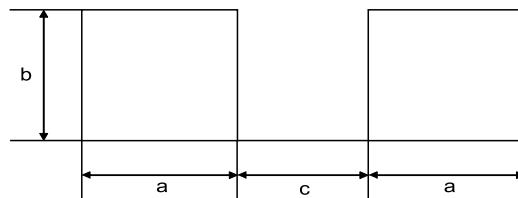

Symbol	A	B	C
ASES 12U 02 0R2	0.4	0.6	0.64
ASES 12U 03 0R2	0.6	0.8	1.1

(mm)

Overview

AMES series is specially designed to protect sensitive electronics from the threat of the electrostatic discharge (ESD). The product reacts almost instantly to the transient voltage and effectively clamps it to the low voltage for the duration of the ESD transient. The product uses voltage variable polymers that inherently produce low capacitance and very low leakage current. Thus the device is virtually invisible to the circuit during normal operational mode. It is especially transparent to the high-speed digital circuits due to the high off-state impedance and low capacitance. Signals are not distorted or disrupted as shown by extensive testing. Using the ESD-Suppressor ESD protection, devices maintain signal integrity of high-speed data signals while protecting the circuit from ESD. The nature of the material creates a bi-directional part, which means that only one device per surge path is required to provide complete ESD protection regardless of the surge polarity.



Features

- 2510mm size
- 4 line ESD protection
- IEC 61000-4-2 Level 4
- Ultra low capacitance (0.2pF typ.)
- Very low leakage current
- Fast response time
- Bi-directional
- Surface mounting package RoHS compliant for global applications.

Application

- High Speed Data Ports (IEEE 1394 , HDMI/DVI)
- Computers & Peripherals (HDTV, Set top box, Notebook, DVD players)

Equivalent Circuit

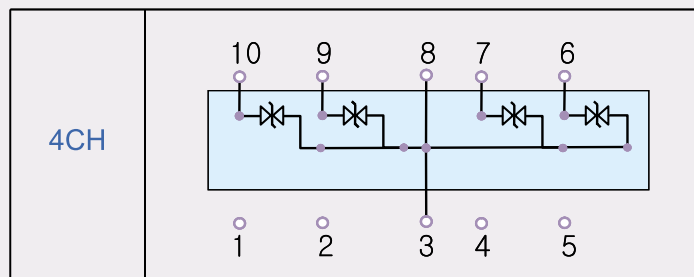

Ordering Information

AMES **12** **U** **05** **Q** **0R2**

① ② ③ ④ ⑤ ⑥

- ① **Series Name**
AMES : Amotech Multi-Channel type ESD Suppressor
- ② **Maximum continuous working voltage** : 12 : 12V
- ③ **Capacitance group** : U : Ultra low capacitance

- ④ **Chip Size** : 05 : 2.5 x 1.0 mm
- ⑤ **Configuration** : Q : Quad array (4-element)
- ⑥ **Typical Capacitance** : 0R2 : 0.2 pF

Electrical Characteristics

Part No.	Rated Voltage Vdc ⁽¹⁾	Clamping Voltage ¹ (Vc_ESD)	Trigger Voltage ² (Vt)	Capacitance (Cp, @ 1MHz)	Leakage Current (IL, @ 12Vdc)	ESD Capability @ IEC61000-4-2 Contact, Air discharge	ESD Pulse Withstand ¹	Operating Temperature
unit	(V)	(V)	(V)	(pF)	(nA)	(KV)		(°C)

Array type 2510 size (4-element)

AMES 12U 05Q 0R2	12 typ	65 typ, 100 max	100 typ	0.2 typ, 0.3 max.	0.1 typ	8 typ, 15 typ.	>1,000 typ.	-40 to +85
------------------	--------	-----------------	---------	-------------------	---------	----------------	-------------	------------

⁽¹⁾Maximum continuous DC working voltage

Dimension Specification

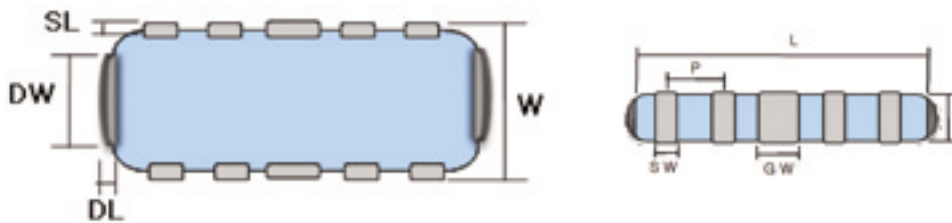

Symbol	L	W	T	DL	DW	SL	SW	GW	P
2510 (4-element)	2.5 ±0.10	1.0 ±0.10	0.58 ±0.10	MAX. 0.2	MAX 0.7	0.25 ±0.10	0.20 ±0.10	0.40 ±0.10	0.50 ±0.10

Solder Pad Layout

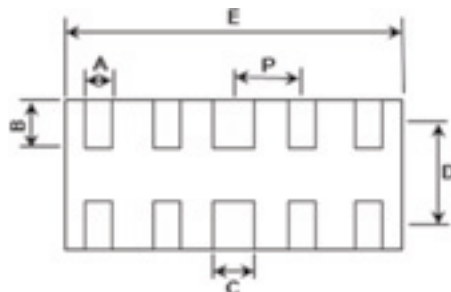

Symbol	A	B	C	D	E	F
2510 (4-element)	0.20	0.42	0.40	1.02	2.50	0.50

ESD Attenuation Test setup

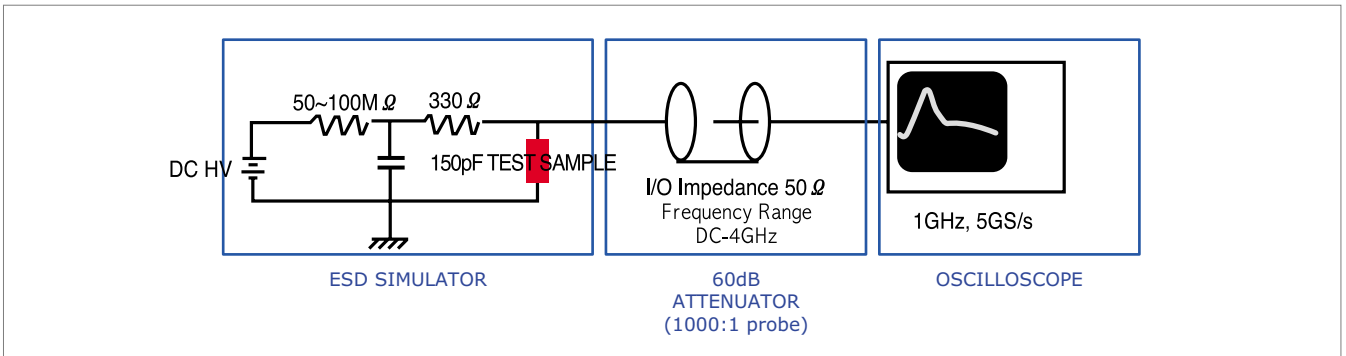

ESD absorption characteristics (voltage waveform)

ESD Suppressor (Single type)

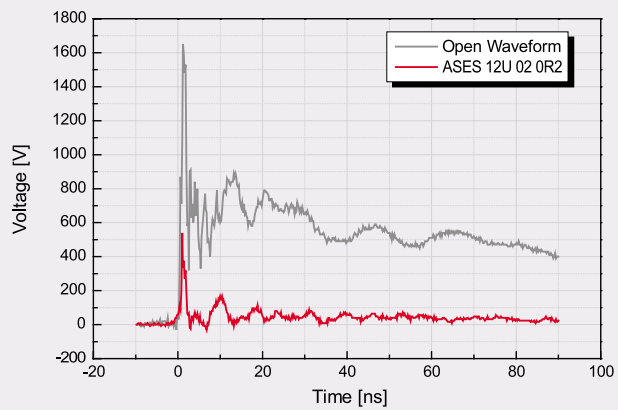

ESD Suppressor (Array type)

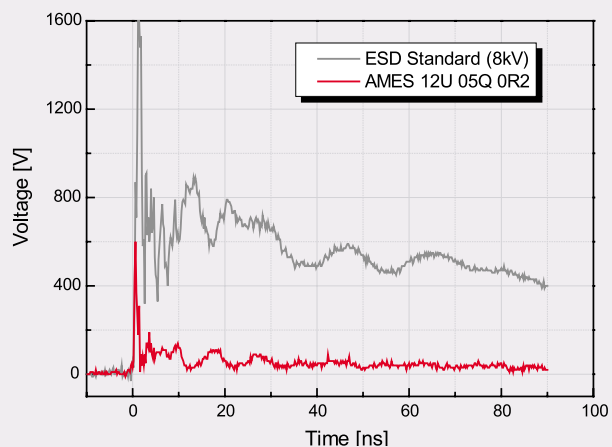

Suppressor TDR data for HDMI

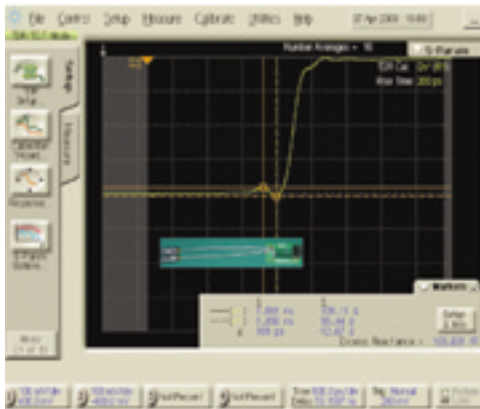

Suppressor Eye Pattern data for HDMI

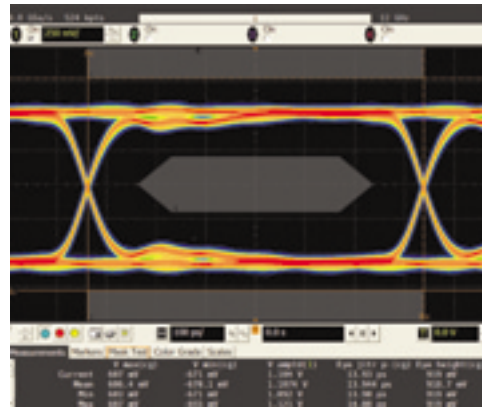

HDMI Eye Pattern Result(1.4Gbps)

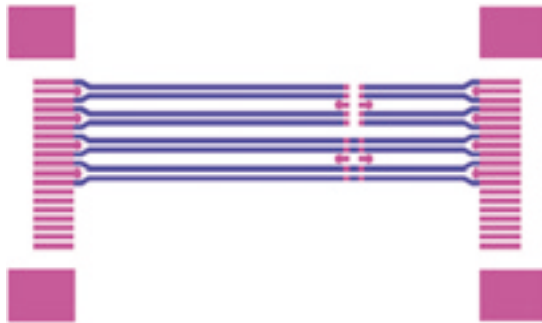

100Ω Differential Impedance
Max 109Ω, Min 96Ω

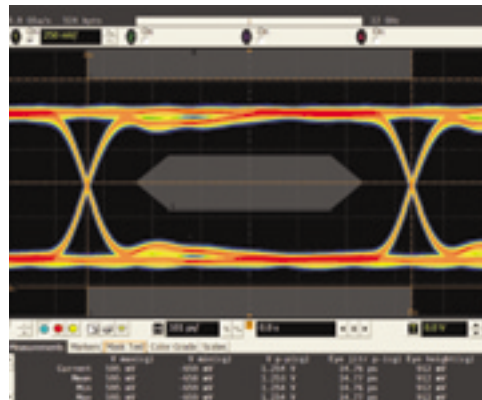

HDMI Eye Pattern Result(2.25Gbps)

Overview

AMO-CAP is an enhanced ESD protection device with low capacitance. This product uses metal-oxide material which has low dielectric constant and high over-current endurance. Using this product ESD protect, devices maintain signal integrity of high speed data line while protecting the circuit from ESD. Thus, this product is suitable for high speed data line and RF part.

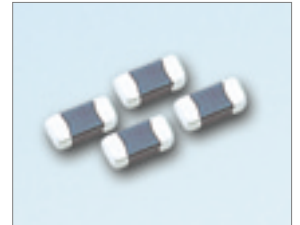

Features

- Multilayer laminated structure
- Ultra low capacitance ideal for high speed data applications.
- High reliability over multi surge
- Forward & Reverse (+, -) direction property
- Low leakage current and inductance
- Easy to control electric capacity
- Excellent reliability against ESD

Application

- This surface mount package protects mobile communications, computers, data processing, test equipment, and many other electronic applications from ESD.

- RF system
- Mobile Phone / PDAs
- ESD Protection for RF Transceiver
- SAW filter
- Wireless Handsets
- Diode switch

Equivalent Circuit

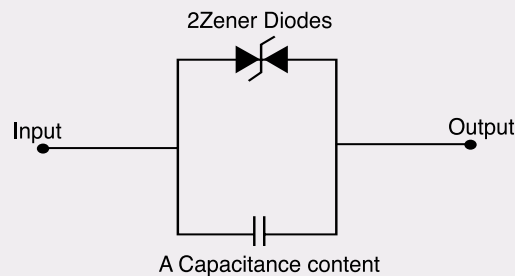

Ordering Information

AD UC 10 S 02 1R1
 ① ② ③ ④ ⑤ ⑥

① **Product group**

AD : Advance metal oxide diode (New varistor material)

② **Capacitance group :**

UC : ~ 10 pF, **LC** : 10 ~ 100 pF, **MC** : 200 pF ~

③ **Working voltage :** **5** : 5.5 V, **10** : 10 V, **30** : 30 V, **40** : 40 V

④ **Vn tolerance :** **S** : Special order **M** : 20 % tolerance

⑤ **Chip Size :** **02** : 1.0 × 0.5 mm, **03** : 1.6 × 0.8 mm

⑥ **Typical Capacitance :**

1R1 : 1.1pF, **3R3** : 3.3 pF, **010** : 10 pF, **200** : 200 pF

Electrical Characteristics

Part No.	Working Voltage Vdc ⁽¹⁾	Breakdown Voltage (Vn) @ 1mA dc	Typical Capacitance (Cp) @ 1MHz, 0.5Vrms	Leakage Current (IL) @ Vdc	Insulation Resistance (IR) @ 3.6 Vdc
unit	(V)	(V)	(pF)	(μ A)	(Ψ)

0402 (1005) size

ADUC 10S 02 0R5	10 max.	95 (75~115)	0.5 (0.3~0.7)	20 max.	10 min.
ADUC 10S 02 1R1	10 max.	85 (65~105)	1.1 (0.8~1.4)	20 max.	10 min.
ADUC 10S 02 1R5	10 max.	50 (30~70)	1.5 (1.0~1.9)	20 max.	10 min.
ADUC 10S 02 3R3	10 max.	30 (21~39)	3.3 (2.3~4.3)	20 max.	10 min.
ADUC 10S 02 005	10 max.	20 (14~26)	5.0 (3.5~6.5)	20 max.	10 min.
ADUC 10S 02 010	10 max.	20 (14~26)	10.0 (7.0~13.0)	20 max.	10 min.

0603 (1608) size

ADUC 10S 03 1R1	10 max.	85 (65~105)	1.1 (0.8~1.4)	20 max.	10 min.
ADUC 10S 03 1R5	10 max.	50 (30~70)	1.5 (1.0~1.9)	20 max.	10 min.
ADUC 10S 03 3R3	10 max.	30 (21~39)	3.3 (2.3~4.3)	20 max.	10 min.
ADUC 10S 03 005	10 max.	20 (14~26)	5.0 (3.5~6.5)	20 max.	10 min.
ADUC 10S 03 010	10 max.	20 (14~26)	10 (7~13)	20 max.	10 min.
ADUC 30S 03 010	30 max.	50 min	10 (7~13)	10 max.	10 min.
ADMC 5M 03 200	5.5 max.	6.4 min	200 typ.	10 @ 3.3V	10 min.
ADMC 5S 03 200	5.5 max.	12 (8.4~15.6)	200 typ.	10 max.	10 min.

(1) Maximum continuous DC working voltage

Dimension Specification

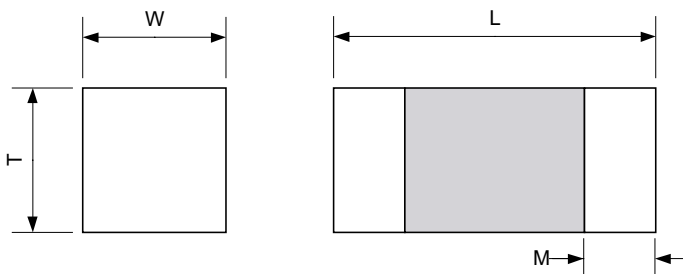

Type	L	W	T	M
0402 (1005)	1.0 ± 0.1	0.5 ± 0.1	Max. 0.6	0.2 ± 0.1
0603 (1608)	1.6 ± 0.15	0.8 ± 0.15	Max. 0.9	0.35 ± 0.15

Solder Pad Layout

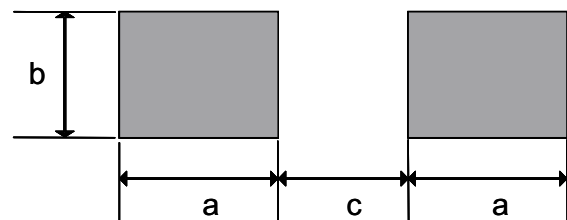

Type	a	b	c
0402 (1005)	0.61	0.51	0.51
0603 (1608)	0.9	0.8	0.8

Frequency Response

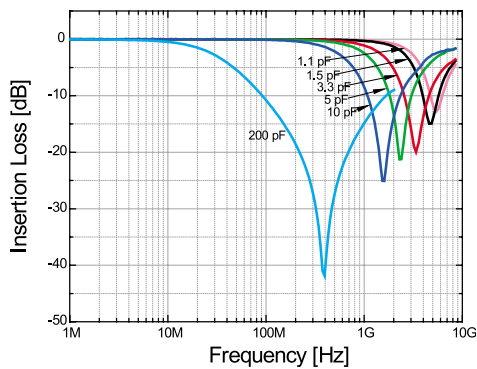

Capacitance vs Frequency characteristics

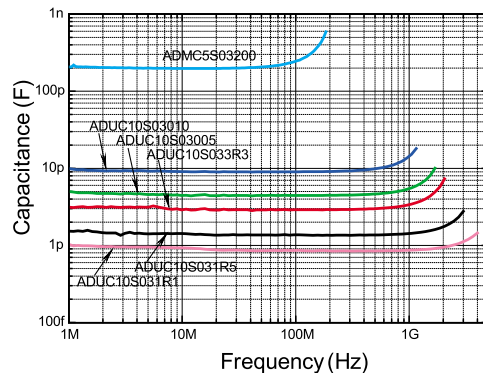

ESD Attenuation Data

- Test Setup

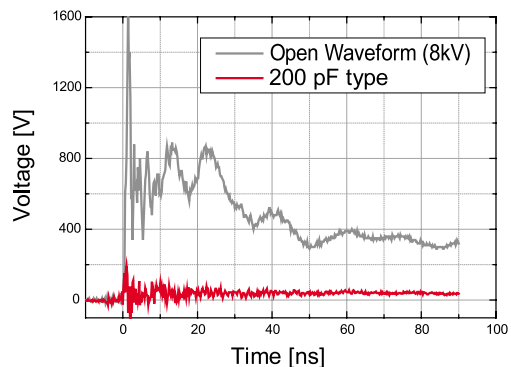
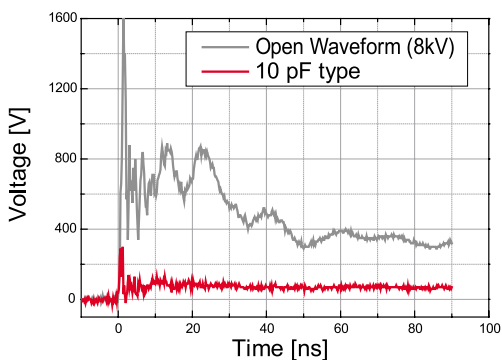
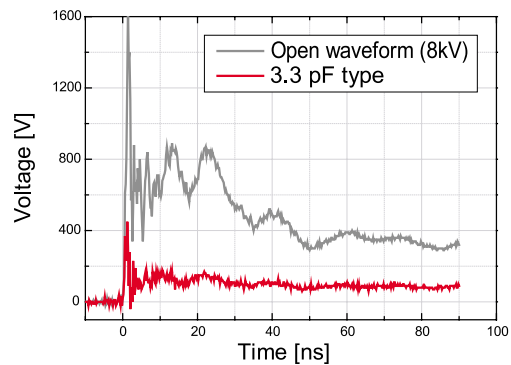
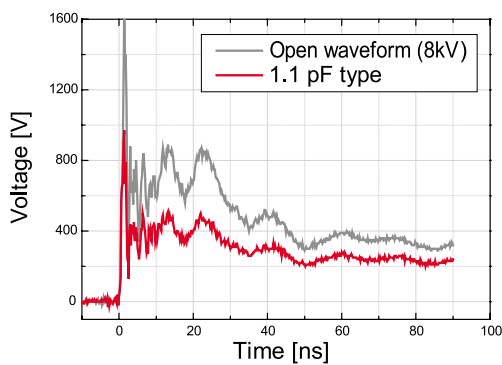
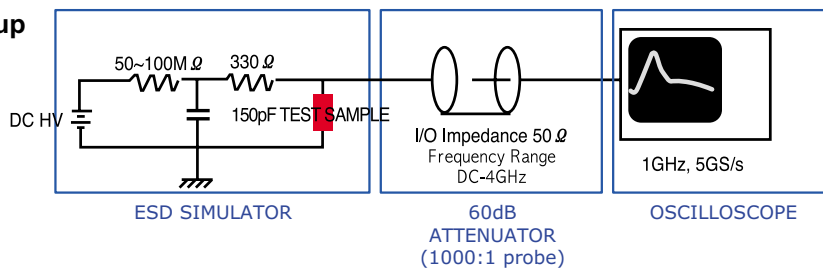

SF, SR Series (0402) / Newly Upgraded ESD Solution Series

AVLC Series (0201) / Compact size & Chip Varistor

AVL, AVLC Series / High Power, General Varistor

AVNC Series (0603, 0805) (4-element) / General Array

AVSC Series (0504, 0805) (4-element) / Compact Array (Space Saved)

Advanced Material On **TECH**nology

GENERAL ESD SOLUTION



SR/SF Series

AMO-Diode

SINGLE RESISTOR TYPE & SINGLE FEED-THRU TYPE

Overview

This product is AMO Diode with more enhanced ESD suppression function than general chip varistor. Its main application fields are various key button-navigation key, side key and key pads and audio part-speaker, receiver, microphone and ear jack. Moreover it shows wide band noise reduction performance.



Features

- Three terminal structure (in, out, 2 GND)
- 0402(1005 mm) size
- IEC 61000-4-2(ESD) Level #4
- Multilayer laminated structure
- Superior ESD performance
- No direction

Application

- Protection for ESD coming into key button, Audio part, etc.,
- Possible to apply variously for elimination of high frequency noise and protection of ESD.

SR Equivalent Circuit

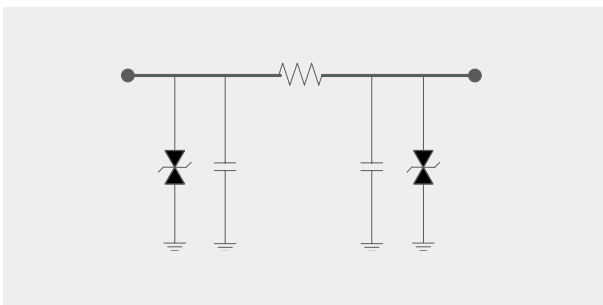

Single SR type

SF Equivalent Circuit

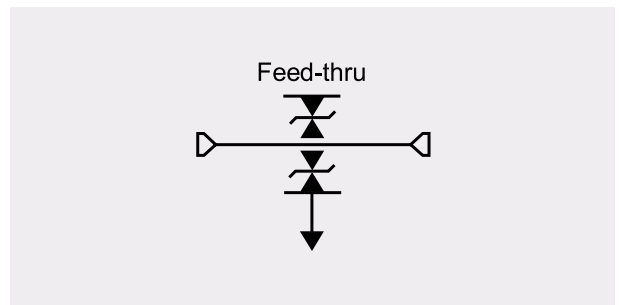

Single SF type

Ordering Information

SR 5 S 02 050 100R

① ② ③ ④ ⑤ ⑥

- Product group**
SR : Single Resistor Type SF : Single Feed - Thru Type
- Working Voltage :**
5 : 5.5V 10 : 10V 30 : 30V 40 : 40V
- Vn tolerance :** S : Special order M : 20 % tolerance

- Chip Size :** 02 : 1.0 x 0.5 mm, 03 : 1.6 x 0.8 mm
- Typical Capacitance :**
010 : 10pF, 020 : 20 pF, 030 : 30 pF, 050 : 50 pF
- Typical Resistance :**
010R : 10Ω, 050R : 50Ω, 100R : 100Ω

SR/SF Series

AMO-Diode

SINGLE RESISTOR TYPE & SINGLE FEED-THRU TYPE

Electrical Characteristics

Part No.	Working Voltage (Vdc)	Breakdown Voltage (Vn) @ 1mA dc	Series resistance between I/O(Rdc)	Rdc tolerance	Capacitance (Cp) @ 1MHz, 0.5Vrms	Capacitance tolerance	Insulation resistance (IR) @3.6 V DC
	(V)	(V)	(Ω)	(%)	(pF)	(%)	(M Ω)

SR Series 0402(1005) size

SR 5S 02 010 010R	5.5	14 ± 4	10	± 30	5+5	± 30	> 10
SR 5S 02 010 050R	5.5	14 ± 4	50	± 30	5+5	± 30	> 10
SR 5S 02 010 100R	5.5	14 ± 4	100	± 30	5+5	± 30	> 10
SR 5S 02 020 100R	5.5	14 ± 4	100	± 30	10+10	± 30	> 10
SR 5S 02 030 010R	5.5	14 ± 4	10	± 30	15+15	± 30	> 10
SR 5S 02 030 050R	5.5	14 ± 4	50	± 30	15+15	± 30	> 10
SR 5S 02 050 050R	5.5	14 ± 4	50	± 30	25+25	± 30	> 10
SR 5S 02 050 100R	5.5	14 ± 4	100	± 30	25+25	± 30	> 10

SF Series 0402(1005) size

SF 5S 02 010	5.5	14 ± 4			10	± 30	> 10
SF 5S 02 030	5.5	14 ± 4			30	± 30	> 10
SF 5S 02 050	5.5	14 ± 4			50	± 30	> 10
SF 5S 02 100	5.5	14 ± 4			100	± 30	> 10

(1) Maximum continuous DC working voltage

Dimension Specification

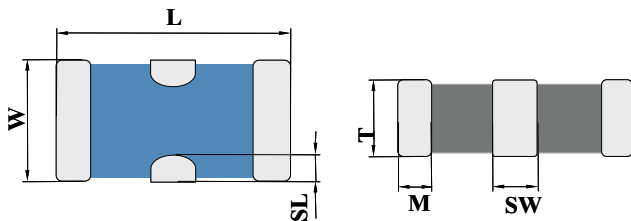

Symbol	L	W	T	M	SW	SL
0402 (1005)	1.0 ± 0.05	0.5 ± 0.05	0.30 ± 0.05	0.15 ± 0.03	0.2 ± 0.05	0.2 ± 0.05

Solder Pad Layout

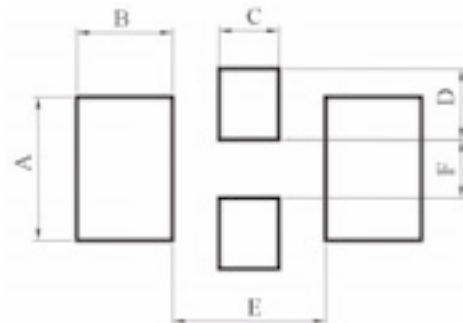

Symbol	A	B	C	D	E	F
0402 (1005)	0.6	0.4	0.25	0.3	0.64	0.24

SR Frequency Response

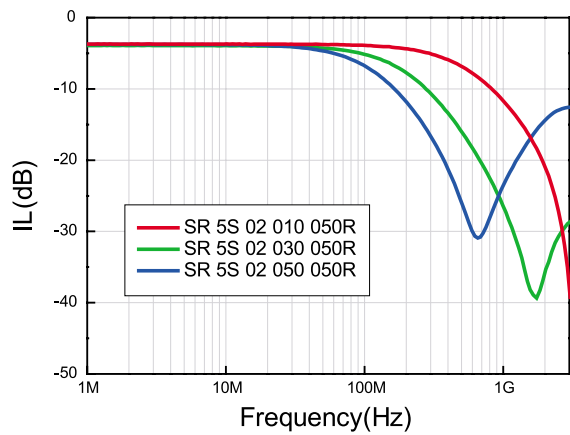

SF Frequency Response

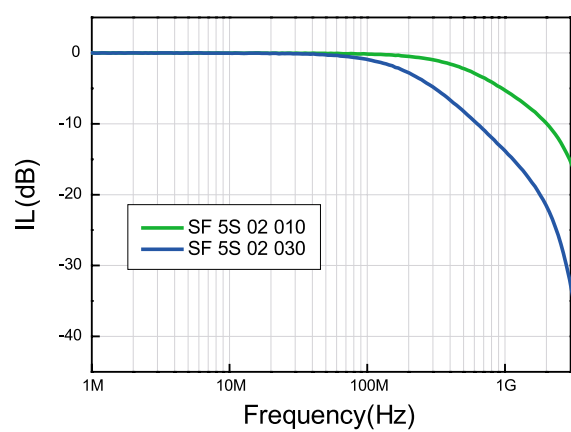

ESD Attenuation Data

- Test Setup

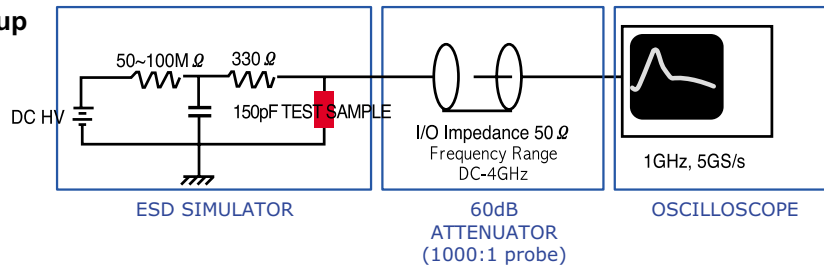

SR ESD Attenuation Characteristics

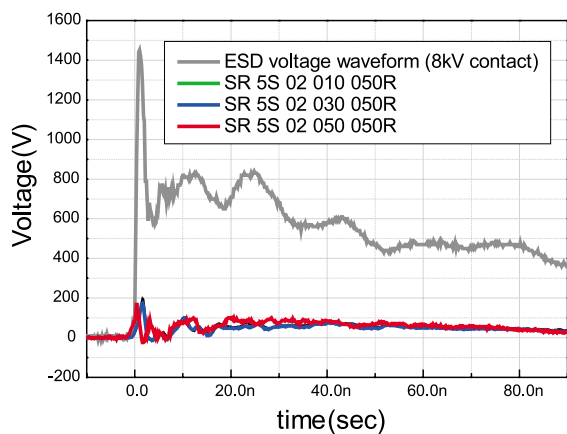

SF ESD Attenuation Characteristics

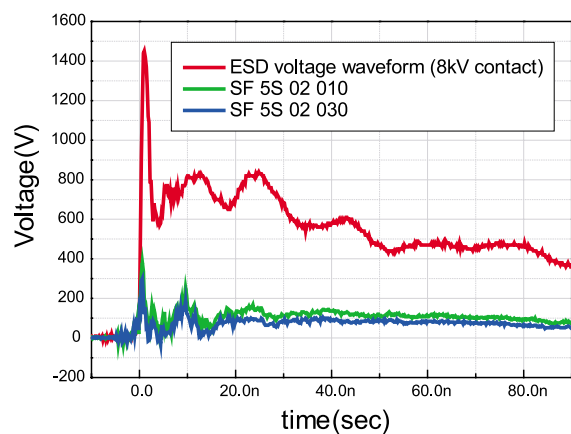

AVLC(0201) Series

Compact Varistor

COMPACT SIZE LOW CAPACITANCE

Overview

This Varistor is a component which acts as a non-conductor on the circuit in normal circumstances. When over-voltage is loaded, it becomes a conductor which diverts over-current from circuits to ground at critical voltage level. Especially, new ultra compact size chip varistor with 0.6 × 0.3 mm dimension can save design space in mobile phone and show even enhanced ESD performance.



Features

- 0201 : 0.6 × 0.3 mm
- Meets IEC 61000-4-2 (ESD) level 4 requirements
- ESD protection > 30 kV
- Fast response time < 1 ns

Application

- All electronic appliances which need ESD protection.
 - LCD Module
 - Mobile Phone / PDAs
 - MP3 Player
 - Digital Camera
 - ESD Protection for sensitive IC
 - I/O Port, Keypad
 - Wireless Handsets
 - Lap top computer
 - Desk top computer
 - Notebook

Equivalent Circuit

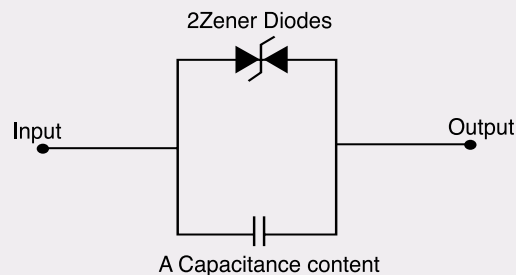

Ordering Information

AVLC **5** **S** **01** **015**

① ② ③ ④ ⑤

① **Series name**

AVLC : Low Capacitance single varistor

② **Working voltage** : **5** : 5.5 V **10** : 10 V

③ **Vn tolerance** : **K** : ± 10 % **L** : ± 20 %

S : Special order

④ **Chip Size** : **01** : 0.6 × 0.3 mm

⑤ **Typical Capacitance** : **005** : 5 pF
015 : 15 pF **030** : 30 pF **100** : 100 pF

Electrical Characteristics

Part No.	Working Voltage (Vdc)	Breakdown Voltage (Vn) @ 1mA dc	Typical Capacitance (Cp) @ 1kHz, 0.5Vrms	Leakage Current (IL) @Vdc	Insulation Resistance (IR) @ 3.6 Vdc
unit	(V)	(V)	(pF)	(μ A)	(Ω)
AVLC 10S 01 005	10 max.	25 (18 ~32)	5 (3.5 ~ 6.5)	20 max.	10 min.
AVLC 5S 01 015	5.5 max.	12.8 (10 ~15.6)	15 (10.5 ~ 19.5)	50 max.	10 min.
AVLC 5S 01 033	5.5 max.	12.8 (10 ~15.6)	33 (23.1 ~ 42.9)	50 max.	10 min.
AVLC 5S 01 050	5.5 max.	12.8 (10 ~15.6)	50 (35.0 ~ 65.0)	50 max.	10 min.
AVLC 5S 01 100	5.5 max.	12.8 (10 ~15.6)	100 (70.0 ~ 130)	50 max.	10 min.

Dimension Specification

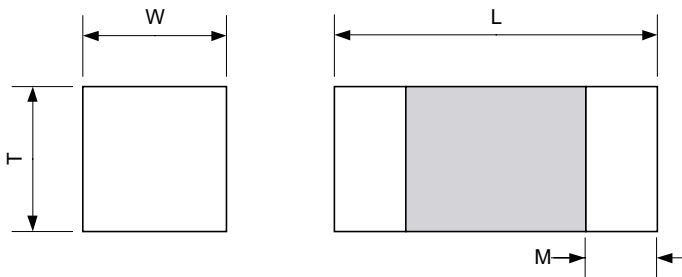

Type	L	W	T	M
0201(0603)mm	0.60 \pm 0.03	0.30 \pm 0.03	0.30 \pm 0.03	Min. 0.1

Solder Pad Layout

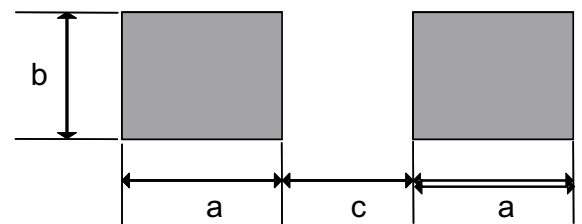

Type	A	B	C
0201(0603)mm	0.2~0.3	0.25~0.3	0.25~0.35

COMPACT SIZE LOW CAPACITANCE

Frequency Response

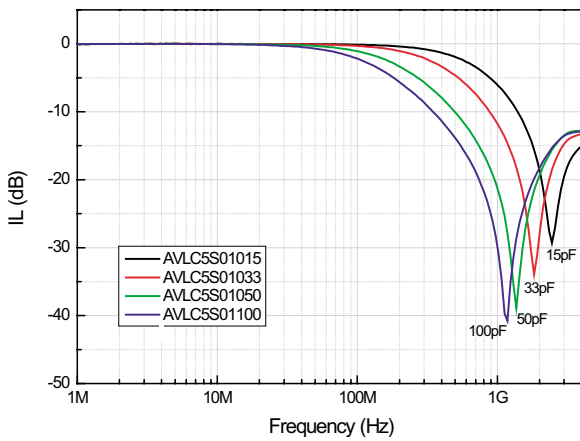

Frequency Response

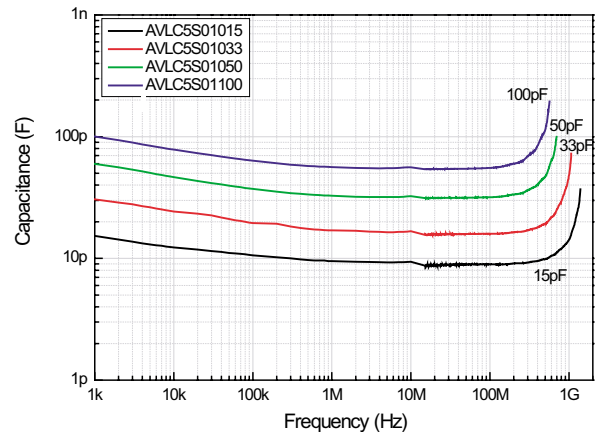

ESD Attenuation Data

- Test Setup

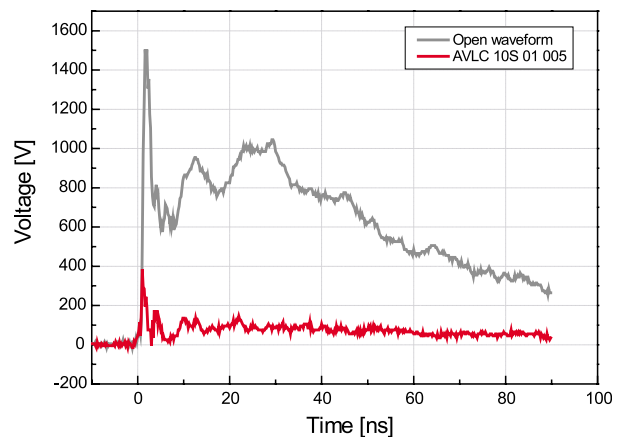
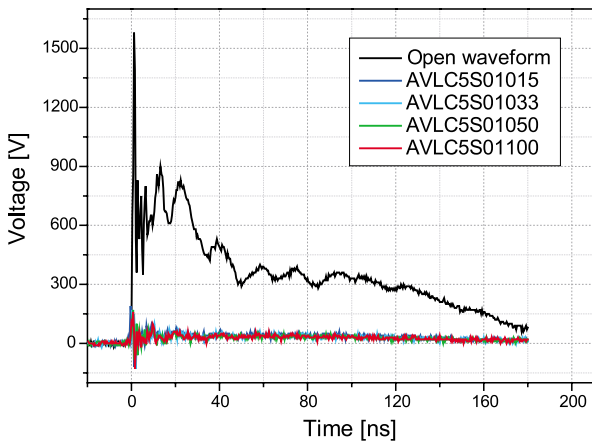
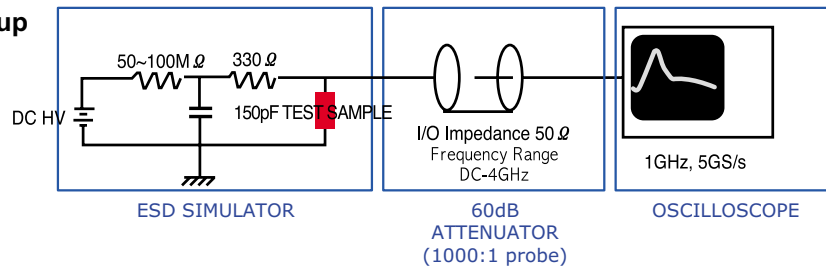

Overview

This Varistor is a component which acts as a non-conductor on the circuit in normal circumstances. When over-voltage is loaded, it becomes a conductor which diverts over-current from circuits to ground at critical voltage level.



Features

- Multilayer construction technology
- Meets IEC 61000-4-2 (ESD), Level 4 requirements
- ESD protection > 30 kV
- Bidirectional clamping and low clamping voltage
- -55°... to + 125°... operating temperature range
- Fast response time < 1 ns

Application

- Mobile Phone / PDAs
- Digital Camera
- ESD Protection for sensitive IC devices
- I/O Port, Keypad for portable devices
- Lap top computer
- Desk top computer
- DVD
- MP3 Player
- Wireless Handsets
- Digital TV
- HDD

Equivalent Circuit

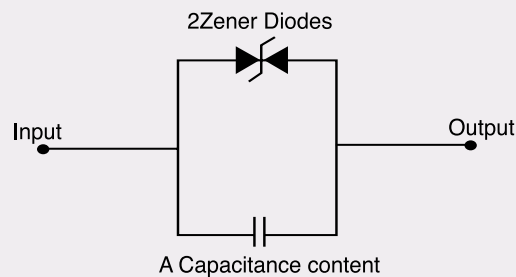

Ordering Information

AVL **5** **M** **02** **200**
 ① ② ③ ④ ⑤

① **Series name**

AVL : Standard Single varistor

AVLC : Low Capacitance single varistor

② **Working Voltage** : **5** : 5.5 V **14** : 14 V **18** : 18 V

③ **Vn tolerance** : **S** : Special order **M** : 20 % tolerance

④ **Chip Size** : **02** : 0402inch (1.0 × 0.5 mm)

03 : 0603inch (1.6 × 0.8 mm)

⑤ **Typical Capacitance** : **AVL** Peak Current : **200** : 20A

AVLC Typical Capacitance : **003** : 3 pF **015** : 15 pF

050 : 50 pF **100** : 100 pF **200** : 200 pF

AVL/AVLC Series General Varistor

HIGH POWER / GENERAL APPLICATION

Electrical Characteristics

Part No.	(Vdc) ⁽¹⁾	Varistor voltage (Vn) @1mA DC	Leakage Current (IL)@Vdc	Cp (@ 1KHz, Vrms =0.5V)	Clamping Voltage (VC)	Peak Current (Imax)	Transient Energy (Wmax)	Insulation Resistance (IR) @3.6V
	(V)	(V)	(μ A)	(pF)	(V)	(A)	(J)	(M Ω)

0402 (1005) size

AVL 5M 02 200	5.5	8 (6.4~9.6)	Max. 20	480 (336~624)	Max. 15.5	Min. 20	Min. 0.05	Min. 10
AVL 14K 02 200	14	18 (16.2~19.8)	Max. 20	160 (112~208)	Max. 35	Min. 20	Min. 0.05	Min. 10
AVLC 5S 02 050	5.5	12 (10 ~ 14)	Max. 20	50 (35 ~ 65)	Max. 25	Min. 10	Min. 0.03	Min. 10
AVLC 5S 02 100	5.5	12 (10 ~ 14)	Max. 20	100 (70 ~ 130)	Max. 25	Min. 10	Min. 0.05	Min. 10
AVLC 5S 02 200	5.5	12 (10 ~ 14)	Max. 20	200 (140 ~ 260)	Max. 25	Min. 10	Min. 0.05	Min. 10
AVLC 14S 02 050	14	21 (18 ~ 24)	Max. 20	50 (35 ~ 65)	Max. 40	Min. 10	Min. 0.03	Min. 10
AVLC 14S 02 100	14	21 (18 ~ 24)	Max. 20	100 (70 ~ 130)	Max. 40	Min. 20	Min. 0.05	Min. 10
AVLC 15S 02 036	15	27 (21.6~32.4)	Max. 20	33 (23.1~42.9)	Max. 40	Min. 10	Min. 0.03	Min. 10
AVLC 18S 02 003	18	125 (90 ~ 160)	Max. 20	@ 1MHz	Max. 300	Min. 1	Min. 0.005	Min. 10
AVLC 18S 02 015	18	28 (24 ~32)	Max. 20	15 (10.5 ~ 19.5)	Max. 45	Min. 10	Min. 0.005	Min. 10

0603 (1608) size

AVL 5M 03 300	5.5	8 (6.4 ~ 9.6)	Max. 20	800 (560 ~ 1040)	Max. 15	Min. 30	Min. 0.1	Min. 10
AVL 14K 03 300	14	18 (16.2 ~ 19.8)	Max. 20	350 (245 ~ 455)	Max. 35	Min. 30	Min. 0.1	Min. 10
AVL 18S 03 300 LC75	18	28 (24~32)	Max. 20	75 (52.5 ~ 97.5)	Max. 40	Min. 30	Min. 0.05	Min. 10
AVL 18S 03 300 LC120	18	28 (24~32)	Max. 20	120 (84 ~ 156)	Max. 40	Min. 30	Min. 0.05	Min. 10

Dimension Specification

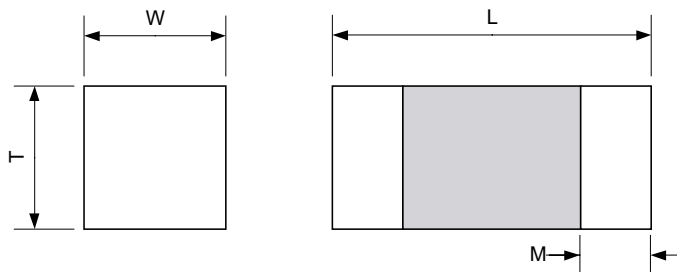

Size(mm)	L	W	T	M
0402 (1005)	1.0 ± 0.10	0.5 ± 0.10	Max. 0.6	0.25 ± 0.15
0603 (1608)	1.6 ± 0.15	0.8 ± 0.15	Max. 0.9	0.35 ± 0.15

Solder Pad Layout

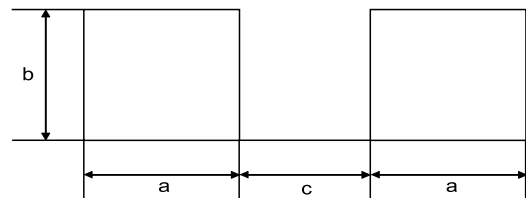

Size(mm)	A	B	C
0402 (1005)	0.61	0.51	0.51
0603 (1608)	0.9	0.8	0.8

Overview

Varistor is a component which acts as a nonconductor on the circuit in normal circumstances. When overvoltage is loaded, it becomes a conductor which diverts overcurrent from circuits to ground at critical voltage level.



Features

- Multilayer laminated structure
- Ultra low capacitance (0.5pF typ.) ideal for high speed data applications.
- High reliability over multi surge
- Forward & Reverse (+, -) direction property
- Low leakage current and inductance
- Easy to control electric capacity
- Excellent reliability against ESD

Application

- The low impedance surface mount package
- LCD Module
- I/O Port Application
- Cellular Phone
- PCMCIA / Compact Flash Card
- RS-232 & RS-423 Data Lines
- DSP Products

Equivalent Circuit

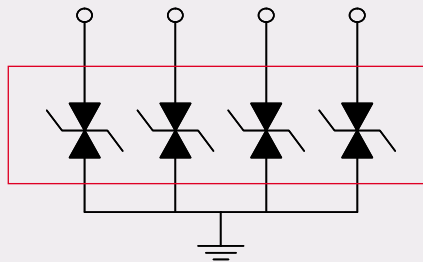

Ordering Information

AVNC **18** **S** **03** **Q** **015**

① ② ③ ④ ⑤ ⑥

① **Series name**

AVNC : General type Chip Array Varistor

② **Maximum continuous working voltage (Vdc) :**

5 : 5.5V **14** : 14V **18** : 18V

③ **Vn tolerance : S** : Special order

④ **Chip dimension : 03** : 0603 (1.60 × 0.80 mm)

05 : 0805 (2.00 × 1.20 mm)

⑤ **Configuration : Q** : 4 elements

⑥ **Capacitance : 015** : 15 pF

050 : 50 pF

MULTILAYER CHIP ARRAY VARISTOR

Electrical Characteristics

Part No.	(Vdc) ⁽¹⁾	Varistor voltage (Vn) @1mA DC	Cp (@ 1kHz, Vrms=0.5V)	Clamping Voltage (VC)	Peak Current (Imax)	Transient Energy	Insulation Resistance (IR) @3.6V
	(V)	(V)	(pF)	(V)	(A)	(J)	(MΩ)

0603(1608mm)Size

AVNC 18S 03Q 015	18 max.	28 (24 ~ 32)	15 (10.5 ~ 19.5)	65	5	0.005	Min. 10
------------------	---------	--------------	------------------	----	---	-------	---------

0805(2012mm)Size

AVNC 5S 05Q 050	5.5 max.	12 (10 ~ 14)	50	25	10	0.03	Min. 10
AVNC 14S 05Q 050	14 max.	21 (18 ~ 24)	50	40	10	0.03	Min. 10
AVNC 18S 05Q 050	18 max.	28 (24 ~ 32)	50	65	5	0.03	Min. 10
AVNC 18S 05Q 015	18 max.	28 (24 ~ 32)	15	65	5	0.005	Min. 10

Dimension Specification

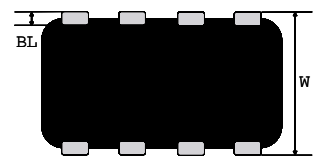
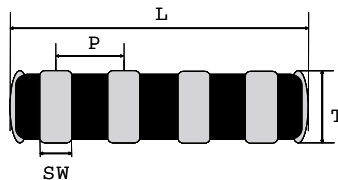

Item	L	W	T	BW	BL	P
0603 (1608) mm	1.60 ± 0.10	0.80 ± 0.10	0.44 ± 0.05	0.20 ± 0.05	0.15 ± 0.05	0.400 ± 0.05
0805 (2012) mm	2.05 ± 0.10	1.25 ± 0.10	0.55 ± 0.10	0.25 ± 0.10	0.25 ± 0.10	0.50 ± 0.10

Solder Pad Layout

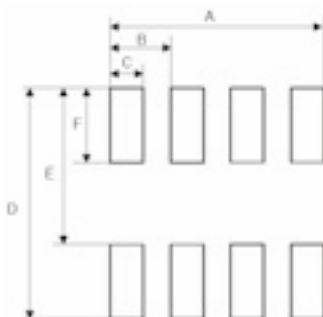

Item	A	B	C	D	E	F
0603 (1608) mm	1.4	0.4	0.2	1.20	0.8	0.4
0805 (2012) mm	1.81	0.51	0.28	1.91	1.27	0.64

Overview

Varistor is a component which acts as a nonconductor on the circuit in normal circumstances. When overvoltage is loaded, it becomes a conductor which diverts overcurrent from circuits to ground at critical voltage level.



Features

- 0504 (1409 mm) size - 4 elements in one chip
- 0805 (2012 mm) size - 8 elements in one chip
- ESD protection > 30 kV
- Fast response time < 1 ns

Application

- LCD Module
- MP3 Player
- ESD Protection for sensitive IC
- Lap top computer
- I/O Port, Keypad for portable devices
- Mobile Phone / PDAs
- Digital Camera
- Wireless Handsets
- Desk top computer

Equivalent Circuit

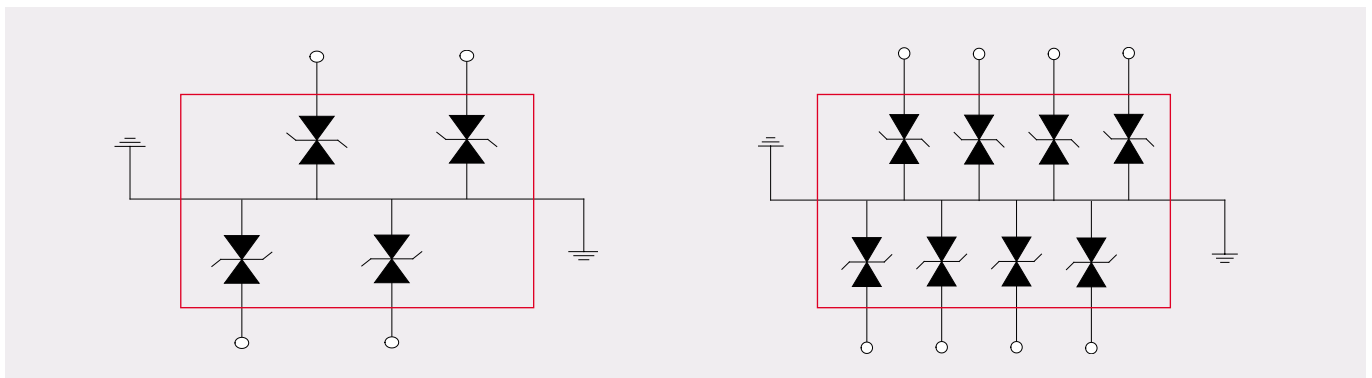

Ordering Information

AVSC **5** **S** **04** **F** **050**

① ② ③ ④ ⑤ ⑥

① **Series name**

AVSC : Compact Array Varistor

② **Maximum continuous working voltage (Vdc) :**

5 : 5.5V **14** : 14V **18** : 18V

③ **Vn tolerance : S** : Special order

④ **Chip dimension : 04** : 0504 (1.4 × 0.9 mm)

05 : 0805 (2.0 × 1.2 mm)

⑤ **Configuration : F** : Four array **E** : Eight array

⑥ **Capacitance : 007** : 07 pF typical **015** : 15 pF typical
025 : 25 pF typical **050** : 50 pF typical

Electrical Characteristics

Part No.	Max. cont. Vdc ⁽¹⁾	Varistor voltage (Vn)	Response time	Cp (@ 1MHz)	Cp toleranc	IR
Unit	(V)	(V)	(nS)	(pF)	(%)	(Ω)

0504 (1409mm) Size

AVSC 18S 04F 007	18	30 (24~36)	<1	7	± 30	Min. 10
AVSC 14S 04F 015	14	23 (18~28)	<1	15	± 30	Min. 10
AVSC 5S 04F 025	5.5	14 (10~18)	<1	25	± 30	Min. 10
AVSC 5S 04F 050	5.5	10 (10~18)	<1	50	± 30	Min. 10

0805 (2012mm) Size

AVSC 18S 05E 007	18	30 (24~36)	<1	7	± 30	Min. 10
AVSC 14S 05E 015	14	23 (18~28)	<1	15	± 30	Min. 10
AVSC 5S 05E 025	5.5	14 (10~18)	<1	25	± 30	Min. 10
AVSC 5S 05E 050	5.5	10 (10~18)	<1	50	± 30	Min. 10

Dimension Specification

4-element

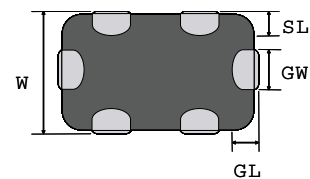
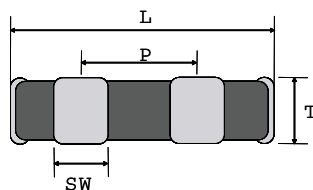
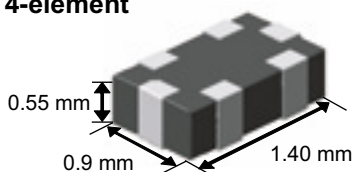

Item	L	W	T	GL	GW	SL	SW	P
0504(1409) mm	1.40±0.10	0.90±0.0	0.55±0.15	0.25±0.10	0.30±0.05	0.25±0.10	0.30±0.05	0.64±0.05

8-element

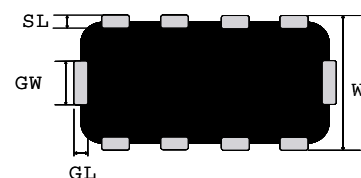
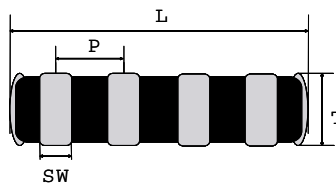
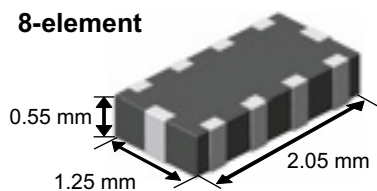

Item	L	W	T	GL	GW	SL	SW	P
0805(2012) mm	2.05±0.10	1.25±0.10	0.55±0.10	0.25±0.10	0.30±0.10	0.25±0.10	0.25±0.10	0.50±0.10

Solder Pad Layout

4-element

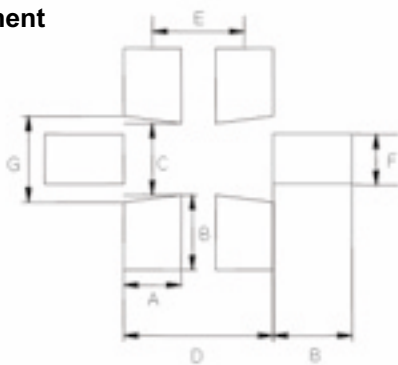

Size(mm)	A	B	C	D	E	F	G
0504(1409)	0.35	0.5	0.5	1.04	0.64	0.35	0.65

8-element

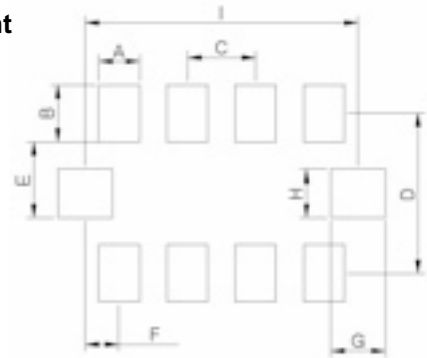

Size(mm)	A	B	C	D	E	F	G	H	I
0805(2012)	0.3	0.42	0.5	1.17	0.55	0.25	0.4	0.35	2

ESD Attenuation Data

- Test Setup

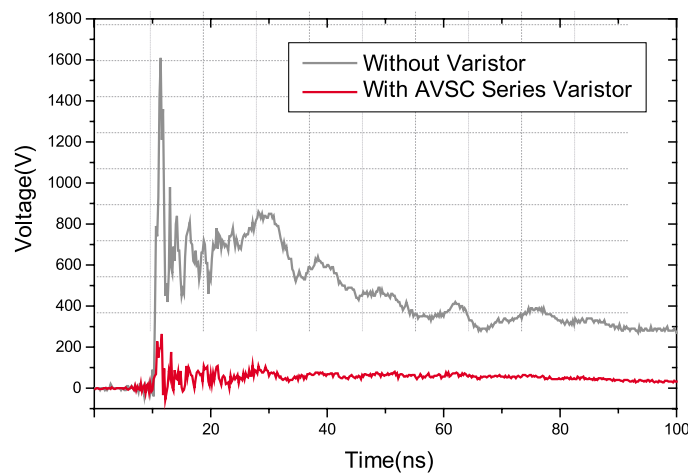
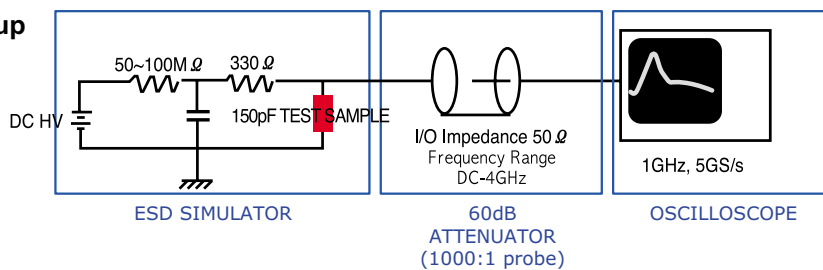



Advanced **M**aterial **O**n **T**ECHnology

EMI/ESD SOLUTION

AMLV 0603 (4-element) / L-C Type EMI-ESD Filter

AVRC Series (0603, 0805) (4-element) / R-C Type

AVRC Series (0504) (2-element) / R-C Type

AVFC Series (0603, 0805) (4-element) / Feed-Thru Type

AVFC Series (0504) (2-element) / Feed-Thru Type

AMLV Series

EMI/ESD Filter

L-C Type 4 Array

Overview

This product is a multi-functioned filter for EMI/ESD protection with L-C structure of type "L", and mainly uses it to interrupt EMI noise at the end of camera and LCD, and uses to protect ESD of high voltage. Especially, it shows its excellent reduction characteristics at the 800 ~ 3,000GHz band in the receiving base band of terminal.



Features

- L-C type 4 channels array filter
- 0603 size
- IEC 61000-4-2 (ESD) Level #4,
- Multilayer laminated structure

Application

- Possible to apply variously for elimination of high frequency noise, and protection of ESD.
- Intercept noise generating from control line and data line of LCD & Camera module.
- Interrupt ESD flowing into the LCD and camera module.

Equivalent Circuit

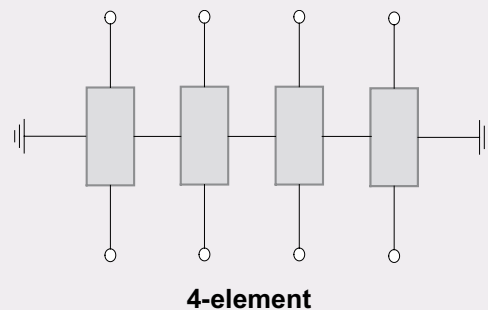
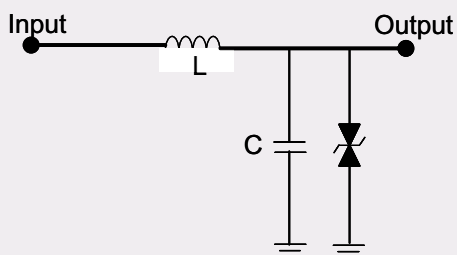

Ordering Information

AMLV 14 S 03 Q 022 200F
① ② ③ ④ ⑤ ⑥ ⑦

① Product group

AM LV : L-C Type EMI & ESD filter

② Working voltage :

5 : 5.5V 14 : 14V 18 : 18V

③ Vn tolerance : S : Special order M : 20 % tolerance

④ Chip Size : 03 : 1.6 x 0.8 mm

⑤ Configuration : Q : Quad array (4-element)

⑥ Typical Capacitance : 022 : 22 pF

⑦ Typical cut-off Frequency :

200F : 200MHz

AMLV Series

EMI/ESD Filter

L-C Type 4 Array

Electrical Characteristics

Part No.	(Vdc) ⁽¹⁾	Varistor voltage (Vn) @1mA DC	Cp (@ 1MHz, Vrms=0.5V)	Cp tolerance	IR (@3V DC)	Cut-off Frequency (-3dB)	Minimum -20dB ATT. Band
	(V)	(V)	(pF)	(%)	(MΩ)	MHz	MHz
AMLV 14S 03Q 012 300F	14	23±5	12	±30	> 10	300	900~6000
AMLV 14S 03Q 022 200F	14	23±5	22	±30	> 10	200	700~6000

Dimension Specification

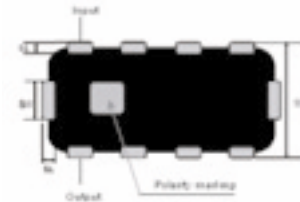
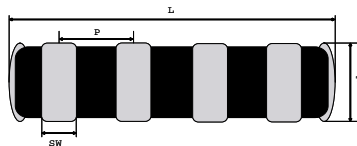
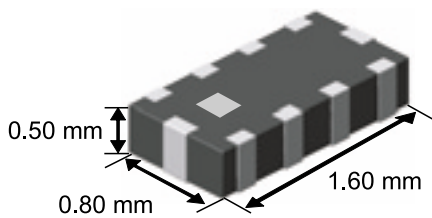

Item	L	W	T	GL	GW	SL	SW	P
Size	1.6±0.1	0.8±0.1	0.5(max.)	0.15±0.05	0.2±0.05	0.15±0.05	0.2±0.05	0.4±0.05

Solder Pad Layout

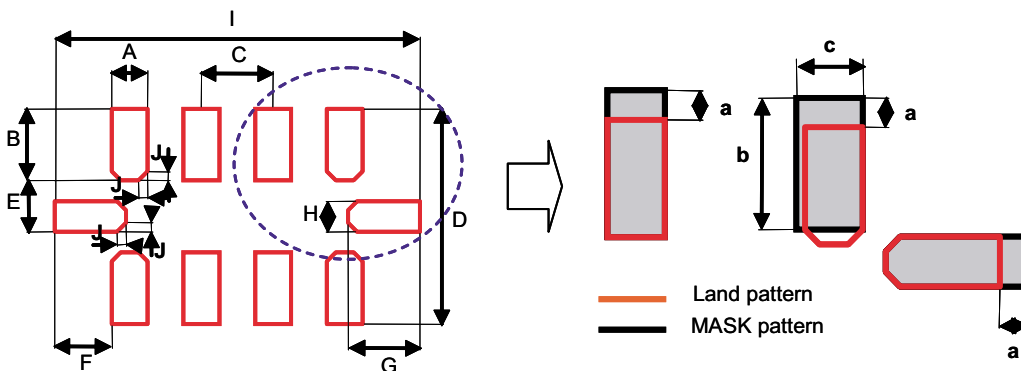

Item	A	B	C	D	E	F	G	H	I	J
Size (mm)	0.2	0.4	0.4	1.2	0.285	0.32	0.4	0.17	2.04	0.05

Item	A	B	C
Size (mm)	0.1	0.45	0.23

AMLV Series

EMI/ESD Filter

L-C Type 4 Array

Frequency Response

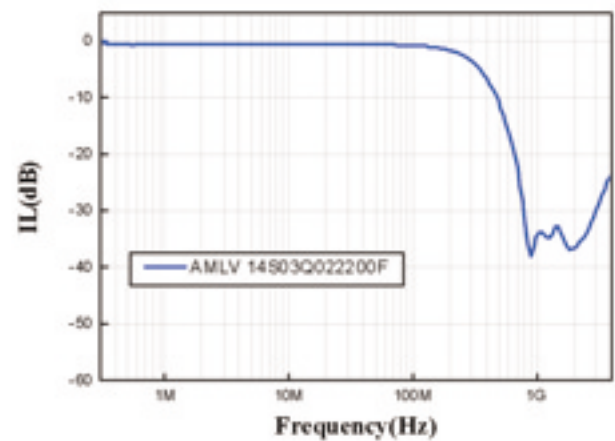
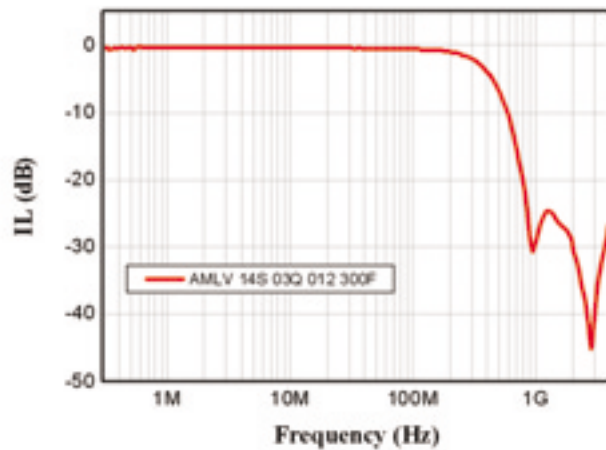

ESD Attenuation Data

- Test Setup

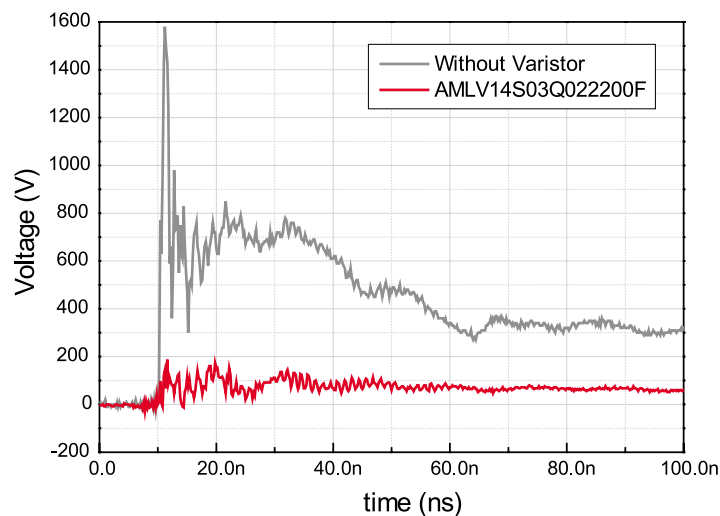
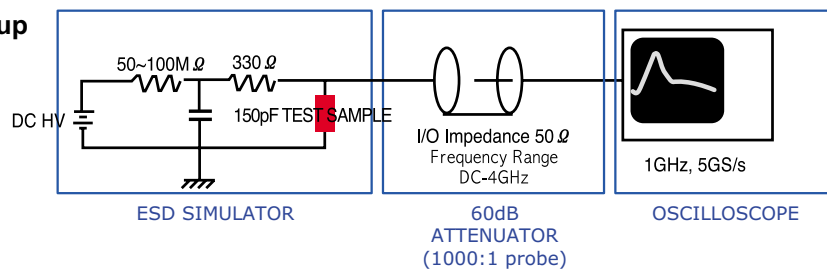

AVRC Series

EMI/ESD Filter

R-C Type 4 Array

Overview

EMI/ESD filter of AMOTECH is an ultra compact sized and multi-functioned filter for EMI/ESD protection with C-R-C structure of type “ π ” (pi), and mainly uses it to interrupt EMI noise at the end of camera and LCD, and uses to protect ESD of high voltage. Especially, it shows its excellent reduction characteristics at the 800 ~ 3,000GHz band in the receiving base band of terminal.



Features

- RC type four channel array filter
- Meets IEC 61000-4-2 (ESD) level 4 requirements
- MLS level #1
- ESD protection > 30 kV
- Fast response time < 1 ns

Application

- Electronic appliance for elimination of high frequency noise, and protection on ESD.
 - LCD module
 - Mobile Phone / PDAs
 - MP3 player
 - Digital camera
 - ESD Protection for sensitive IC
- I/O connection
- Camera module
- Wireless Handsets
- Desk top computer
- Notebook

Equivalent Circuit

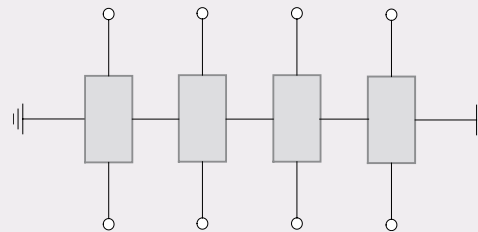
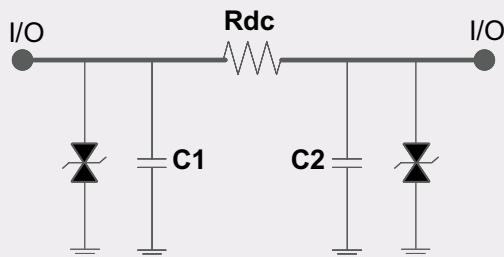

4-array type

Ordering Information

AVRC **14** **S** **03** **Q** **030** **050R**
① ② ③ ④ ⑤ ⑥ ⑦

① Series name

AVRC : R-C Type EMI & ESD filter

② Maximum continuous working voltage (Vdc) :

5 : 5 V 14 : 14 V 18 : 18 V

③ Varistor voltage tolerance : S : Special order

④ Chip Size : 03 : 0603 (1.6 × 0.8 mm) 05 : 0805 (2.0 × 1.2 mm)

⑤ Configuration : Q : Quad array (4 elements)

⑥ Capacitance : 015 : 15pF 030 : 30pF 050 : 50pF 100 : 100pF

⑦ Series Resistance : 010R : 10 ohm 050R : 50 ohm

100R : 100 ohm

AVRC Series

EMI/ESD Filter

R-C Type 4 Array

Electrical Characteristics

Part No.	(Vdc) ⁽¹⁾	Varistor voltage (Vn) @1mA DC	Rdc R series between I/O (2)	Rdc tolerance	Cp (@ 1MHz, Vrms =0.5V) C1+C2	Cp tolerance	IR (@3V DC)	Cut-off Frequency (-3dB)	Minimum -20dB ATT. Band
	(V)	(V)	(Ω)	(%)	(pF)	(%)	(MΩ)	MHz	MHz

0603 (1608) size

AVRC 5S 03Q 050 050R	5.5	14±4	50	±30	25+25	±30	> 10	70	600~3000
AVRC 5S 03Q 050 100R	5.5	14±4	100	±30	25+25	±30	> 10	70	450~3000
AVRC 5S 03Q 050 200R	5.5	14±4	200	±30	25+25	±30	> 10	70	350~3000
AVRC 5S 03Q 050 400R	5.5	14±4	400	±30	25+25	±30	> 10	70	300~3000
AVRC 14S 03Q 030 050R	14	23±5	50	±30	15+15	±30	> 10	100	800~3000
AVRC 14S 03Q 030 100R	14	23±5	100	±30	15+15	±30	> 10	100	700~3000
AVRC 14S 03Q 030 200R	14	23±5	200	±30	15+15	±30	> 10	100	650~3000
AVRC 18S 03Q 015 010R	18	30±6	10	±30	7.5+7.5	±30	> 10	350	1700~3000
AVRC 18S 03Q 015 050R	18	30±6	50	±30	7.5+7.5	±30	> 10	350	1500~3000
AVRC 18S 03Q 015 100R	18	30±6	100	±30	7.5+7.5	±30	> 10	350	1100~3000
AVRC 18S 03Q 007 010R	18	40±8	10	±30	3.5+3.5	±30	> 10	850	3500~5000
AVRC 18S 03Q 007 050R	18	40±8	50	±30	3.5+3.5	±30	> 10	850	3100~5000

0805 (2012) size

AVRC 5S 05Q 050 050R	5.5	14±4	50	±30	25+25	±30	> 10	100	550~3000
AVRC 5S 05Q 050 100R	5.5	14±4	100	±30	25+25	±30	> 10	100	400~3000
AVRC 5S 05Q 050 200R	5.5	14±4	200	±30	25+25	±30	> 10	80	300~3000
AVRC 5S 05Q 100 100R	5.5	14±4	100	±30	50+50	±30	> 10	45	200~3000
AVRC 14S 05Q 030 050R	14	23±5	50	±30	15+15	±30	> 10	150	750~3000
AVRC 14S 05Q 030 100R	14	23±5	100	±30	15+15	±30	> 10	150	700~3000
AVRC 14S 05Q 030 200R	14	23±5	200	±30	15+15	±30	> 10	120	400~3000
AVRC 18S 05Q 007 050R	18	105±45	50	±30	3.5+3.5	±30	> 10	1000	3000~5000
AVRC 18S 05Q 007 100R	18	105±45	100	±30	3.5+3.5	±30	> 10	1000	2800~5000
AVRC 18S 05Q 015 010R	18	30±6	10	±30	7.5+7.5	±30	> 10	700	1900~5000
AVRC 18S 05Q 015 050R	18	30±6	50	±30	7.5+7.5	±30	> 10	450	1500~3000
AVRC 18S 05Q 015 100R	18	30±6	100	±30	7.5+7.5	±30	> 10	400	1100~3000

(1) Maximum continuous DC working voltage

(2) Series resistance between input and output

AVRC Series

EMI/ESD Filter

R-C Type 4 Array

Dimension Specification

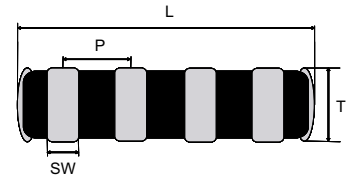
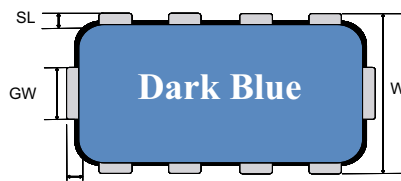
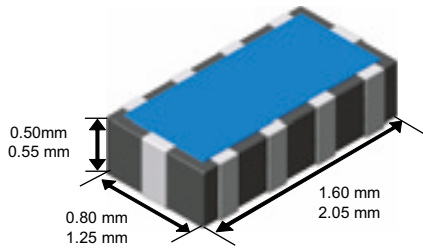

Symbol	L	W	T	GL	GW	SL	SW	P
0603 (1608) size	1.60±0.10	0.80±0.10	0.50 max	0.15±0.05	0.20±0.05	0.15±0.05	0.20±0.05	0.40±0.05
0805 (2012) size	2.05±0.10	1.25±0.10	0.55±0.10	0.25±0.10	0.30±0.10	0.25±0.10	0.25±0.10	0.50±0.10

Solder Pad Layout

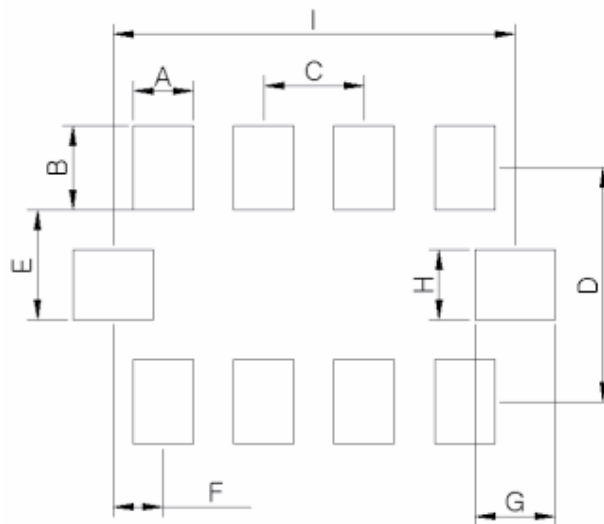

Symbol	A	B	C	D	E	F	G	H	I
0603(1608)size	0.2	0.4	0.4	1.2	0.285	0.32	0.4	0.17	2.04
0805(2012)size	0.3	0.42	0.5	1.17	0.55	0.25	0.4	0.35	2

AVRC Series

EMI/ESD Filter

R-C Type 4 Array

EMI Attenuation Characteristics

- Test Setup

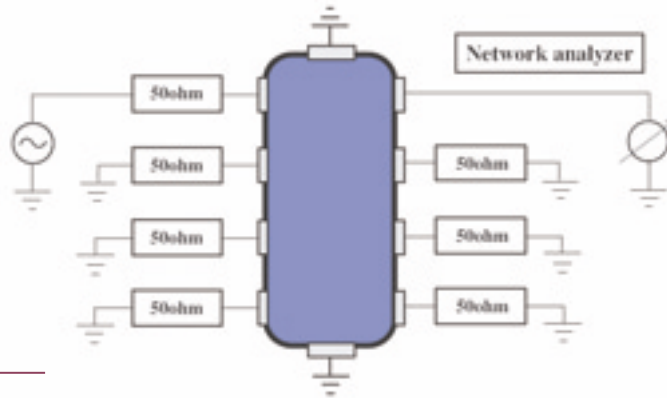

0603 (1608) size

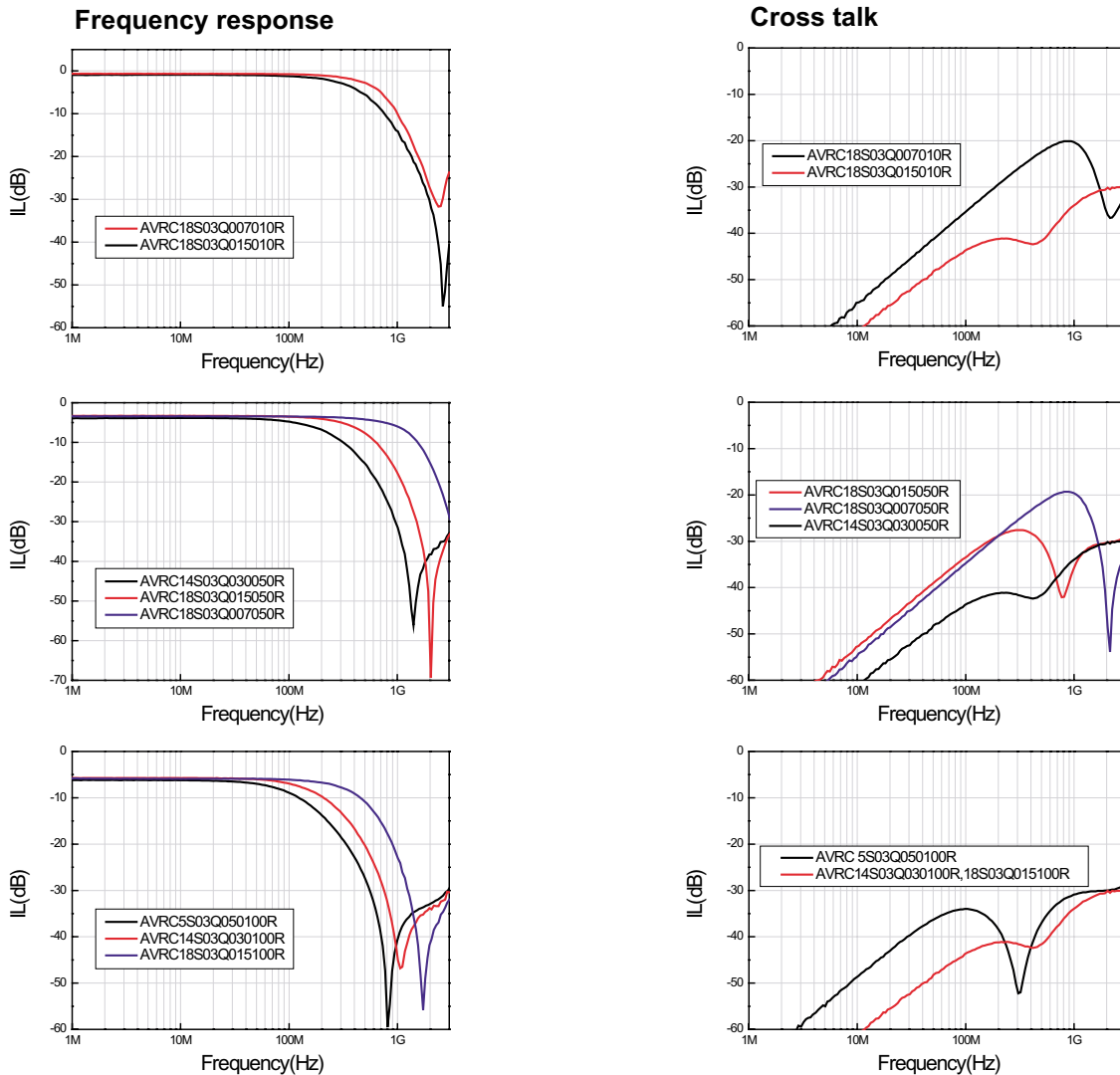

AVRC Series

EMI/ESD Filter

R-C Type 4 Array

● 0603 (1608) size

Frequency response

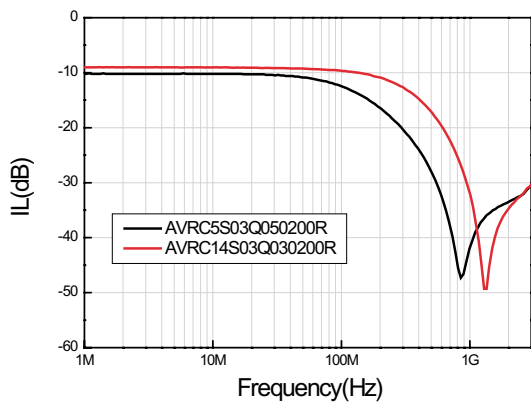

Cross talk

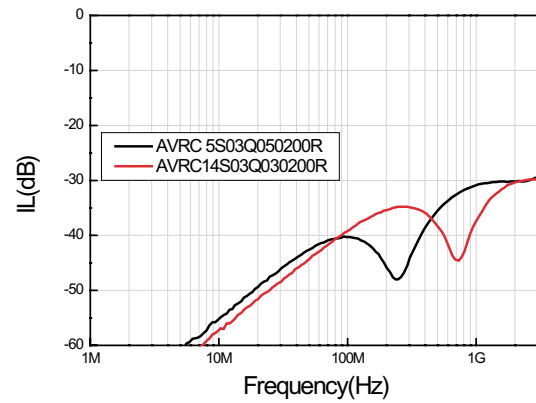
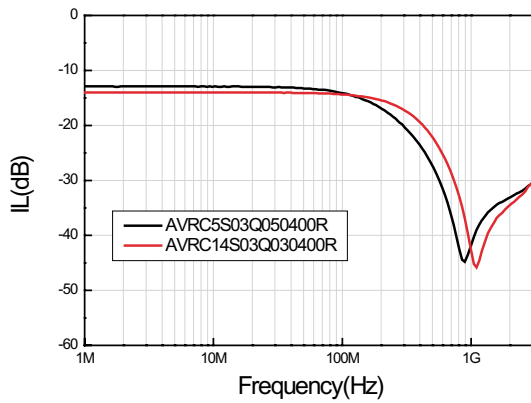
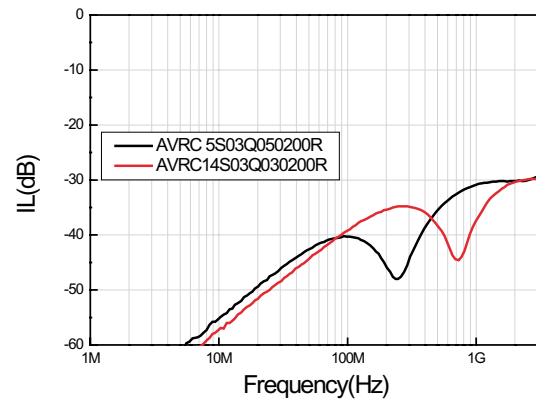

AVRC Series

EMI/ESD Filter

R-C Type 4 Array

EMI Attenuation Characteristics

- Test Setup

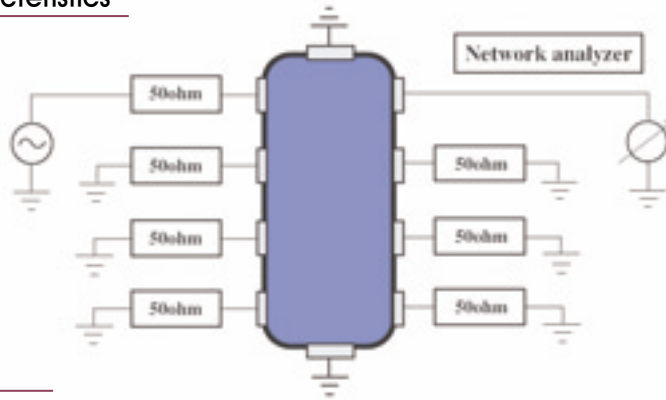

0805 (2012) size

Frequency response

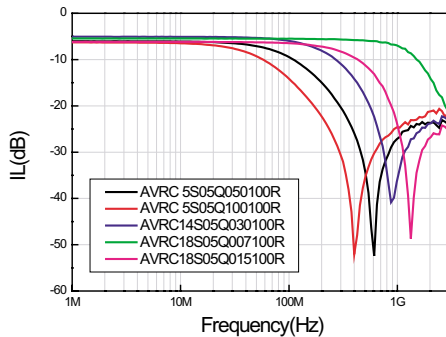
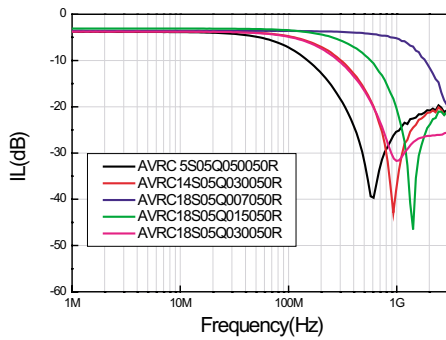
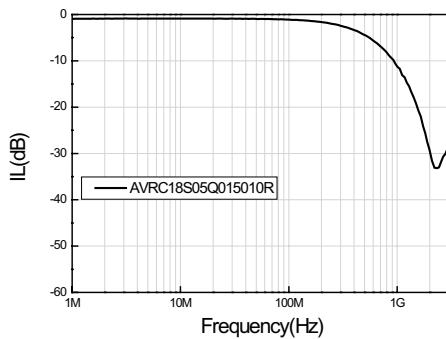

Cross talk

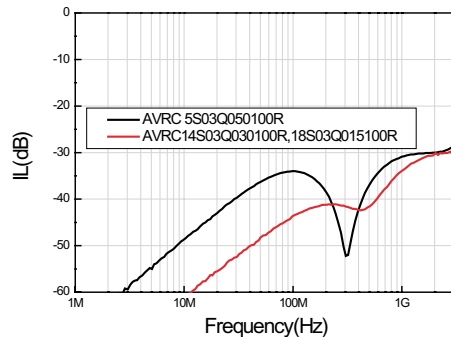
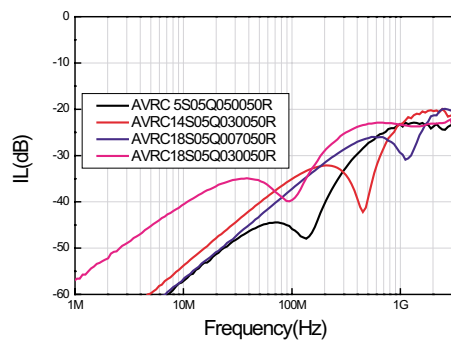
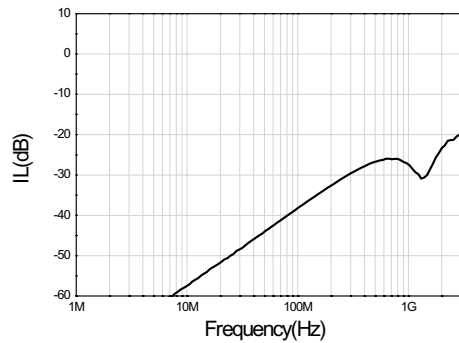

AVRC Series

EMI/ESD Filter

R-C Type 2 Array (Audio part)

Overview

New EMI/ESD filter of AMOTECH is a ultra compact sized and multi-functioned filter for EMI/ESD protection with C-R-C structure of type π (pi), and mainly uses it to interrupt EMI noise at the end of audio part, and uses to protect ESD of high voltage. Especially, it shows its excellent reduction characteristics at the receiving base band of terminal.



Features

- RC type two channel array filter
- 0504 (1409 mm) size
- Meets IEC 61000-4-2 (ESD) level 4 requirements
- ESD protection > 30 kV
- Fast response time < 1 ns

Application

- Electronic appliance for elimination of high frequency noise, and protection on ESD.
 - Mobile Phone / PDAs
 - MP3 player
 - Digital camera
 - ESD Protection for sensitive IC
 - I/O connection
 - Wireless Handsets
 - Desk top computer
 - Notebook

Equivalent Circuit

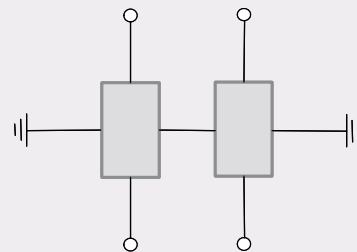
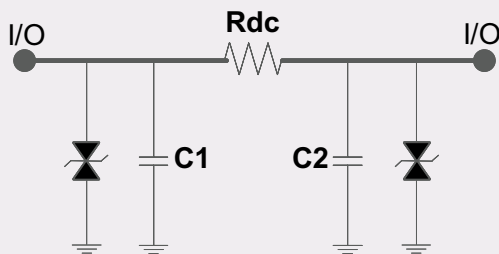

2-array type

Ordering Information

AVRC 14 S 04 D 015 100R
① ② ③ ④ ⑤ ⑥ ⑦

① Series name

AVRC : R-C Type EMI & ESD filter

② Maximum continuous working voltage (Vdc) :

5 : 5V 14 : 14V 18 : 18V

③ Varistor voltage tolerance : S : Special order

④ Chip Size : 04 : 0504 (1.4 x 0.9 mm)

⑤ Configuration : D : Double array (2 elements)

⑥ Capacitance : 015 : C1+C2 = 15 pF 030 : C1+C2 = 30 pF

200 : C1+C2 = 200 pF 350 : C1+C2 = 350 pF

⑦ Typical Resistance : 010R : $10 \pm 3\Omega$ 050R : $050 \pm 15\Omega$

100R : $100 \pm 30\Omega$

AVRC Series

Ultra Compact size EMI/ESD Filter

R-C Type 2 Array (Audio part)

Electrical Characteristics

Part No.		(Vdc) ⁽¹⁾	Varistor voltage (Vn) @1mA DC	Rdc R series between I/O s	Rdc tolerance	Cp (@1KHz, Vrms=0.5V) C1+C2	Cp tolerance	Insulated Resistance (IR) @3V DC	Cut-off Frequency (-3dB)	Minimum -20dB ATT. Band
		(V)	(V)	(Ω)	(%)	(pF)	(%)	(MΩ)	MHz	MHz
Mic.	AVRC 18S 04D 015 100R	18	30±6	100	±30	7.5+7.5	±30	> 10	700	1900~5000
	AVRC 5S 04D 050 100R	5.5	14±4	100	±30	25+25	±30	> 10	100	500~2500
	AVRC 5S 04D 200 100R	5.5	14±4	100	±30	100+100	±30	> 10	100	200~2500
	AVRC 5S 04D 350 100R	5.5	14±4	100	±30	175+175	±30	> 10	100	100~2500
Spk. Rcv.	AVRC 14S 04D 030 010R	14	23±6	10	±30	15+15	±30	> 10	100	1000~2500
	AVRC 5S 04D 200 010R	5.5	14±4	10	±30	100+100	±30	> 10	100	400~2500
	AVRC 5S 04D 350 010R	5.5	14±4	10	±30	175+175	±30	> 10	100	300~2500

- (1) Maximum continuous DC working voltage
 (2) Series resistance between input and output

Dimension Specification

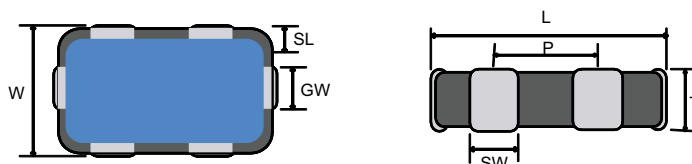

Symbol	L	W	T	GL	GW	SL	SW	P
0504 (1409) size	1.4±0.1	0.9±0.1	0.55±0.15	0.25±0.1	0.3±0.05	0.25±0.1	0.3±0.05	0.64±0.05

Solder Pad Layout



Symbol	A	B	C	D	E	F	G
0504 (1409) size	0.35	0.5	0.5	1.04	0.64	0.35	0.65

AVRC Series

Ultra Compact size EMI/ESD Filter

R-C Type 2 Array (Audio part)

EMI Attenuation Characteristics

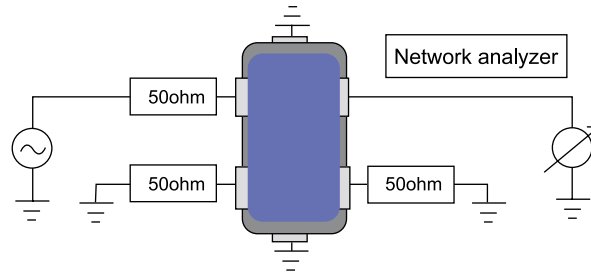

0504 (1409) size

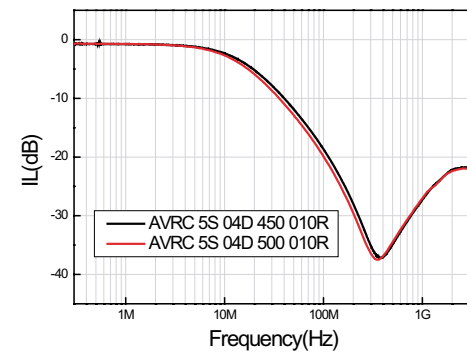
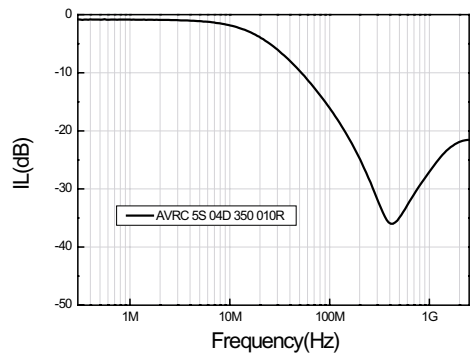
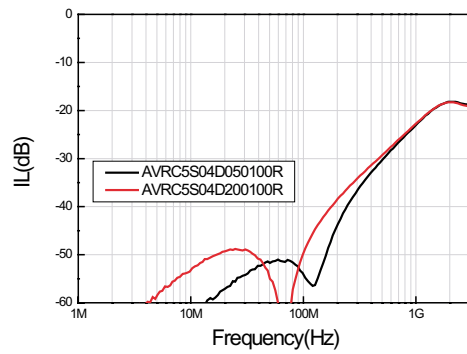
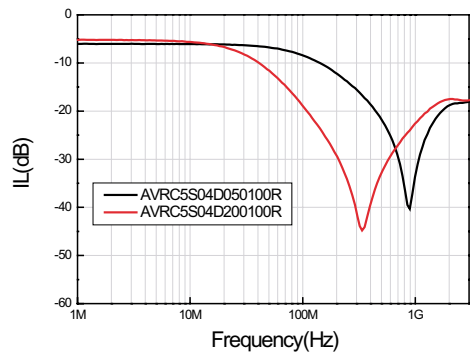
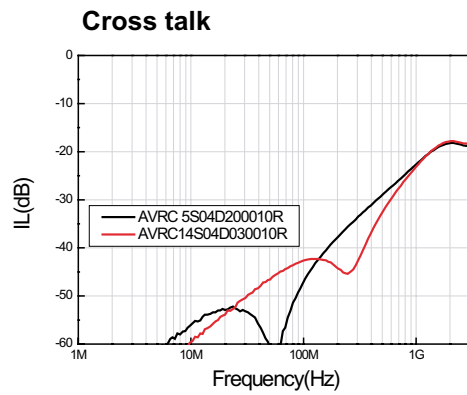
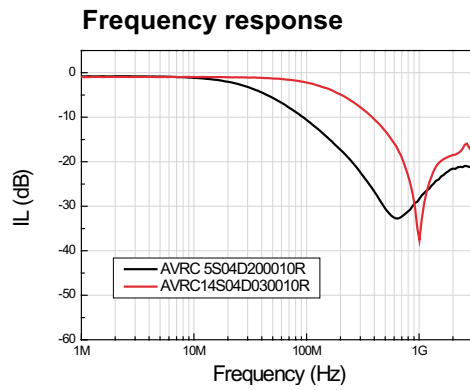

AVFC Series

EMI/ESD Filter

Feed Thru Type 4 Array

Overview

This product is a multi-functioned filter for EMI/ESD protection of Feed through type, and main application fields are ESD protection of power line, remove noise, ESD prevention occurring from audio line such as speaker, receiver, microphone, and ear-jack, also eliminate TDMA noise to enhance audio performance.



Features

- Feed Thru type four channel array filter
- 0805 (2012 mm) size
- 0603 (1608 mm) size
- Meets IEC 61000-4-2 (ESD) level 4 requirements
- ESD protection > 30 kV
- Fast response time < 1 ns

Application

- Electronic appliance for elimination of high frequency noise, and protection on ESD.
 - I/O connection
 - Mobile Phone / PDAs
 - MP3 player
 - Digital camera
 - ESD Protection for sensitive IC
 - power line
 - Serial line
 - Wireless Handsets
 - Desk top computer
 - Notebook

SR Equivalent Circuit

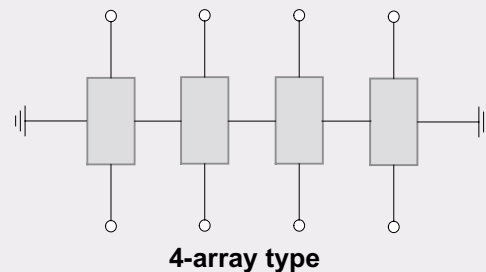
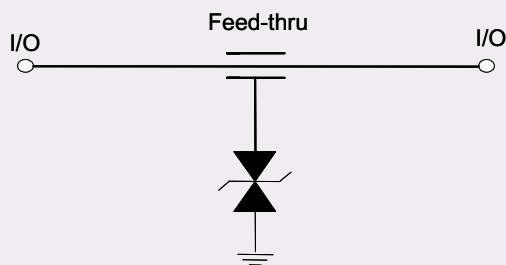

Ordering Information

AVFC **5** **S** **05** **Q** **050**

① ② ③ ④ ⑤ ⑥

- ① **Series Name**
AVFC : Feed Thru Type EMI/ESD Filter
- ② **Maximum continuous working voltage :**
5 : 5.5V 12 : 12V 14 : 14V
- ③ **Varistor voltage tolerance : S :** Special order

- ④ **Chip Size :** 05 : 0805 (2.0 x 1.2mm)
03 : 0603 (1.6 x 0.8 mm)
- ⑤ **Configuration :** Q : 4 element
- ⑥ **Typical Capacitance :** 050 : 50 pF

AVFC Series

EMI/ESD Filter

Feed Thru Type 4 Array

Electrical Characteristics

Part No.	(Vdc) ⁽¹⁾	Varistor voltage (Vn) @1mA DC	Cp (@ 1MHz, Vrms=0.5V)	Cp tolerance	Insulated Resistance IR (@3V DC)	Cut-off Frequency (-3dB)	Minimum -20dB ATT. Band
	(V)	(V)	(pF)	(%)	(MΩ)	MHz	MHz

0603 (1608) Size

AVFC 5S 03Q 033	5.5	14±4	33	±30	> 10	150	1500~3000
-----------------	-----	------	----	-----	------	-----	-----------

0805 (2012) Size

AVFC 5S 05Q 100	5.5	14±4	100	±30	> 10	50	550~3000
AVFC 5S 05Q 050	5.5	14±4	50	±30	> 10	120	1000~3000
AVFC 14S 05Q 030	14	23±5	30	±30	> 10	210	1500~3000
AVFC 18S 05Q 015	18	30±6	15	±30	> 10	450	2500~3000

Dimension Specification

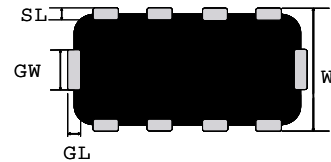
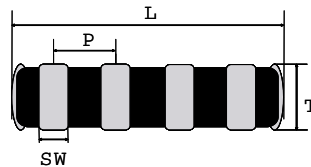
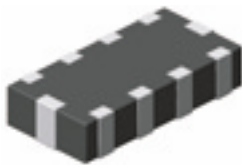

Symbol	L	W	T	GL	GW	SL	SW	P
0603 (1608)	1.6±0.1	0.8±0.1	0.44±0.05	0.15±0.05	0.2±0.05	0.15±0.05	0.2±0.05	0.4±0.05
0805 (2012)	2.05±0.1	1.25±0.1	0.55±0.1	0.25±0.1	0.3±0.1	0.25±0.1	0.25±0.1	0.5±0.1

Solder Pad Layout

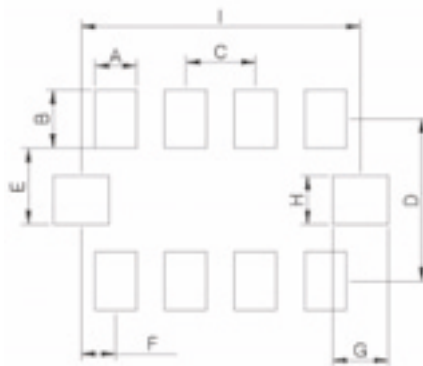

Symbol	A	B	C	D	E	F	G	H	I
0603 (1608)	0.2	0.4	0.4	1.2	0.285	0.32	0.4	0.17	2.04
0805 (2012)	0.3	0.42	0.5	1.17	0.55	0.25	0.4	0.35	2

EMI Attenuation Characteristics

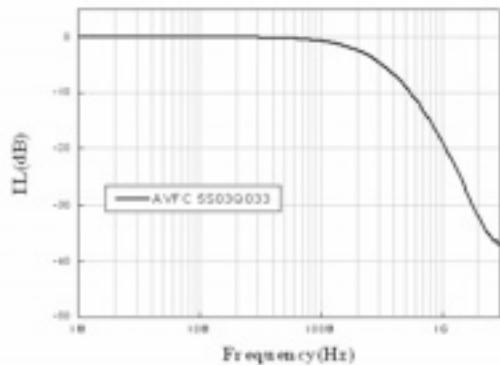
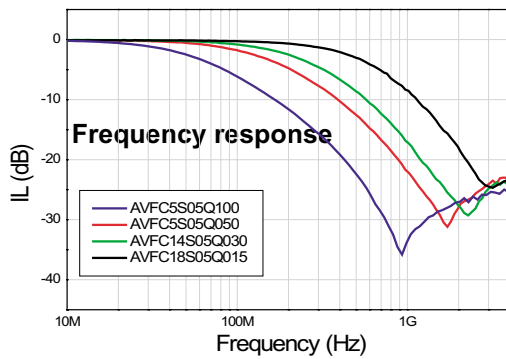
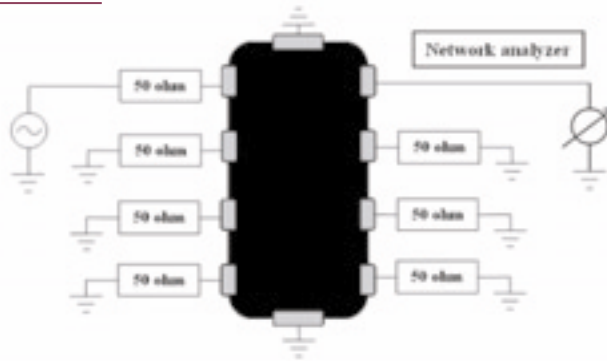

ESD Attenuation Characteristics

- Test Setup

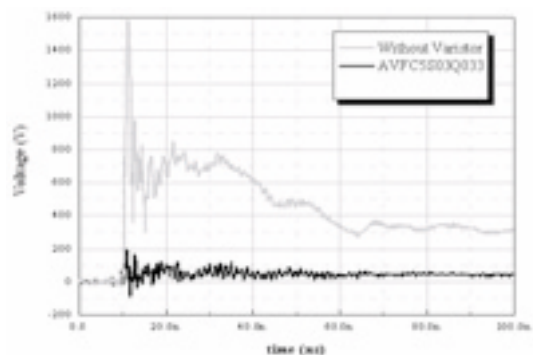
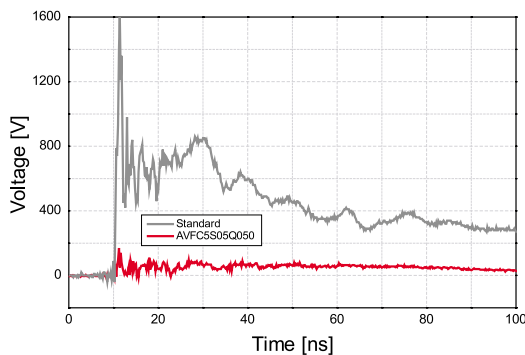
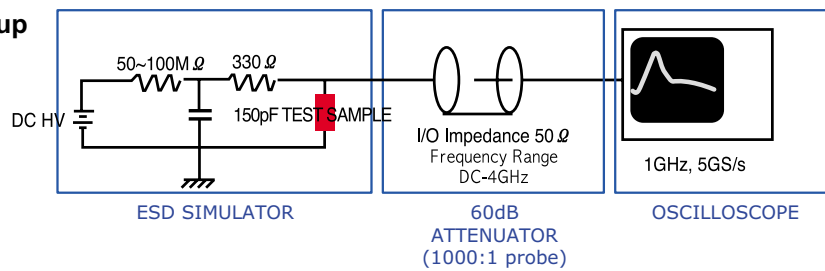

AVFC Series

EMI/ESD Filter

Feed Thru Type 2 Array

Overview

This product is a multi-functioned filter for EMI/ESD protection of Feed through type, and main application fields are ESD protection of power line, remove noise, ESD prevention occurring from audio line such as speaker, receiver, microphone, and ear-jack, also eliminate TDMA noise to enhance audio performance.



Features

- Feed Thru type four channel array filter
- 0504 (1409 mm) size
- Meets IEC 61000-4-2 (ESD) level 4 requirements
- ESD protection > 30 kV
- Fast response time < 1 ns

Application

- Electronic appliance for elimination of high frequency noise, and protection on ESD.
 - I/O connection
 - Mobile Phone / PDAs
 - MP3 player
 - Digital camera
 - ESD Protection for sensitive IC
 - power line
 - Serial line
 - Wireless Handsets
 - Desk top computer
 - Notebook

SR Equivalent Circuit

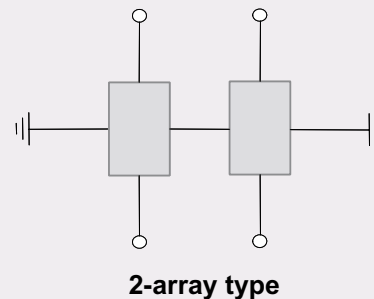
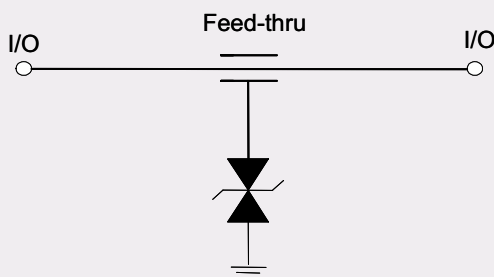

Ordering Information

AVFC **5** **S** **04** **D** **150**

① ② ③ ④ ⑤ ⑥

① Series name

AVFC : Feed Thru Type EMI/ESD Filter

② Maximum continuous working voltage (Vdc) :

5 : 5.5V **12** : 12V **14** : 14V

③ Varistor voltage tolerance : **S** : Special order

④ Chip Size : **04** : 0504 (1.4 x 0.9 mm)

⑤ Configuration :

D : Dual Array (2-element)

⑥ Capacitance :

150 : C1+C2 = 150 pF

AVFC Series

EMI/ESD Filter

Feed Thru Type 2 Array

Electrical Characteristics

Part No.	(Vdc) ⁽¹⁾	Varistor voltage (Vn) @1mA DC	Cp (@ 1MHz, Vrms=0.5V)	Cp tolerance	Insulated Resistance IR (@3V DC)	Cut-off Frequency (-3dB)	Minimum -20dB ATT. Band
	(V)	(V)	(pF)	(%)	(MΩ)	MHz	MHz
AVFC 5S 04D 150	5.5	14 ± 4	100	± 30 (%)	> 10	35	550~4000

Dimension Specification

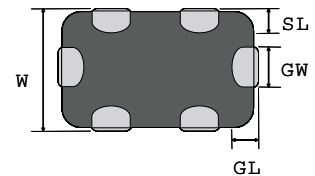
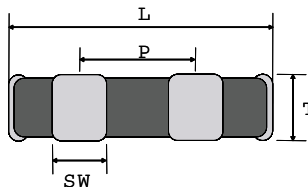
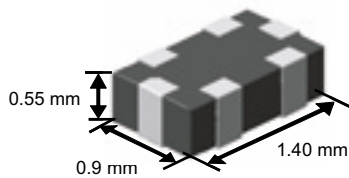

Symbol	L	W	T	GL	GW	SL	SW	P
0504 (1409) size	1.4 ± 0.1	0.9 ± 0	0.55 ± 0.15	0.25 ± 0.1	0.3 ± 0.05	0.25 ± 0.1	0.3 ± 0.05	0.64 ± 0.05

Solder Pad Layout

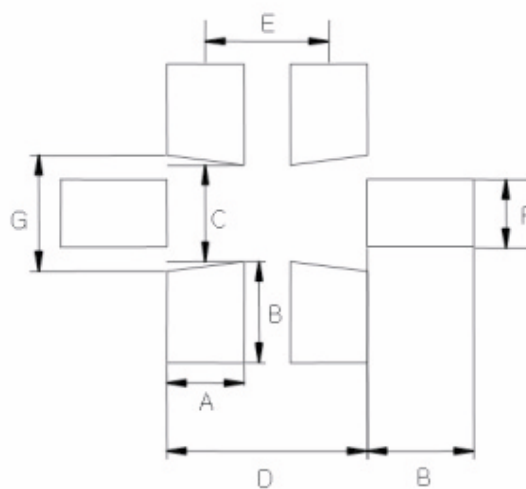

Symbol	A	B	C	D	E	F	G
0504 (1409) size	0.35	0.5	0.5	1.04	0.64	0.35	0.65

AVFC Series

EMI/ESD Filter

Feed Thru Type 2 Array

EMI Attenuation Characteristics

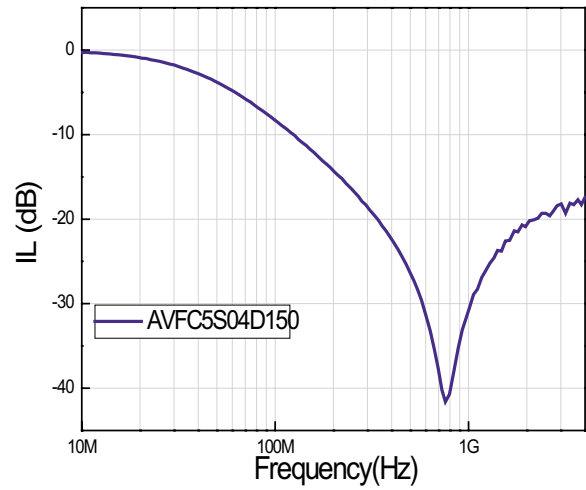
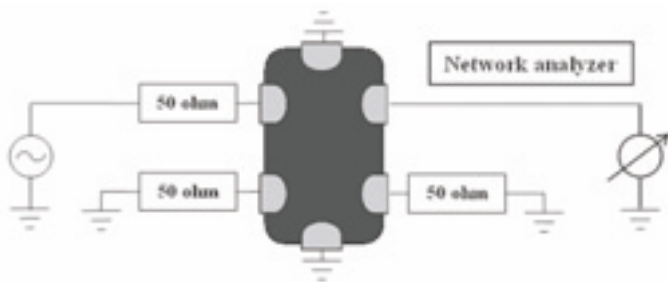

ESD Attenuation Characteristics

- Test Setup

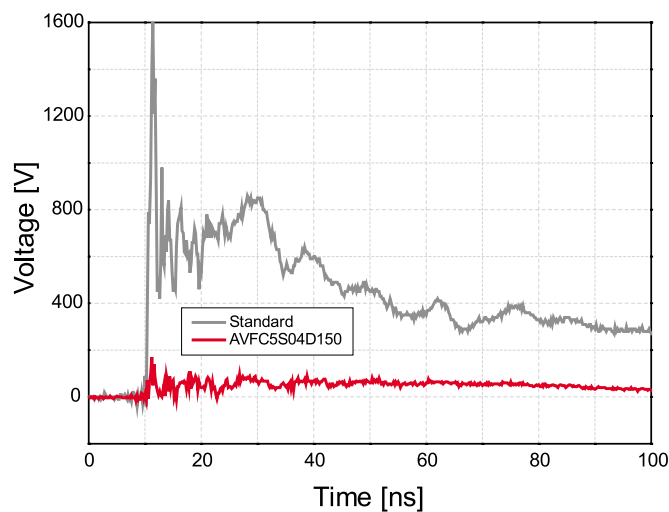
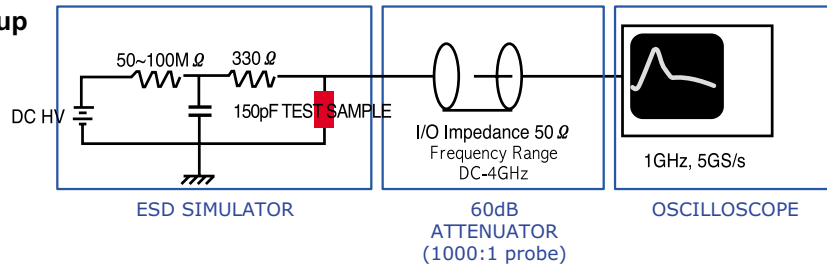

TERMINOLOGY

Term	Symbol	
Rated DC Voltage	Vdc	Maximum continuous DC voltage (<5% ripple) which may be applied to the component under continuous operating conditions at 25°C
Leakage Current	IL	The current passing through the varistor at Vdc and at 25°C
Varistor voltage	Vn	Voltage across the varistor measured at a given reference current In
Clamping Voltage Protection Level	Vc	The peak voltage developed across the varistor under standard atmospheric conditions when passing an 8/20µs class current pulse
Rated Single Pulse Transient Energy	Wmax	Energy which may be dissipated for a single 10/1000µs impulse of a maximum rated current, with rated RMS voltage or rated DC voltage also applied without causing device failure
Rated Peak Single Pulse Transient Current	Imax	Maximum peak current which may be applied for a single 8/20µs impulse, with rated line voltage also applied, without causing device failure
Rated Transient Average Power Dissipation	P	Maximum average which may be dissipated due to a group of pulses occurring within a specified isolated time period, without causing device failure at 25°C
Capacitance	Cp	Capacitance between two terminals of the varistor measured at 1 kHz
Response Time		The time lag between application of a surge and varistor's 'turn-on' conduction action
Insulation Resistance		Minimum resistance between shorted terminals and varistor surface
Isolation Voltage		Minimum voltage applied for one minute between shorted terminals and varistor surface
Operating Temperature		The range of ambient temperature for which the varistor is designed to operate continuously, as defined by the temperature limits of its climatic category
Storage Temperature		Storage temperature range without voltage applied
Current Energy Derating		Derating of maximum values when operated above 85°C

SELECTION GUIDELINES & APPLICATION FIELDS

The selection of Transient Voltage Suppressors involves comparison of device parameter with circuit conditions. The following selection guidelines are recommended:

1. **Select Transient Voltage Suppressors with a rated voltage greater than or equal to the normal operating voltage of the circuit.**
2. **Select Transient Voltage Suppressors which is capable of dissipating the expected transient peak pulse current.**
3. **The Transient Voltage Suppressors clamping voltage should be less than the maximum voltage handling capability of the protected circuit for the same pulse waveform.**
4. **For systems using high speed data rates, Transient Voltage Suppressors capacitance will have to be considered.**

There may be applications where the actual transient current cannot be defined. Often, the designer will have to meet the requirements of certain transient immunity specification. As the very least, identification of the source of the threat is necessary: lightning, inductive switching, ESD, etc.

☉ Summary of Selection

Device Parameter		Circuit Condition
Vdc (V)	≥	120% of Normal circuit operating voltage
I _{max} (A)	≥	Expected transient current
Vc (V)	≤	Maximum allowable voltage across the protected component
Cp (pF)	<	Maximum loading capacitance for signal integrity

Market	Homeappliance	Communication	Computer & Peripheral	Consumer Product	Car Electronics
Application	D-TV / STB / Notebook / Camera HDMI/Dvi Memory Card USB Key Button RF PARTS	Cellular / cordless phone LCD display Programming port Charger Key pads Speaker & Microphone ASIC protection Laser diode protection FETs protection	Personal computer Audio card Keyboards I/O ports RS232/RS422/IEEE 488 Interface card	Security system Sensor protection Key pads Microprocessor reset & I/O protection LCD display CATV LNA FETs protection Logic box protection	ECU protection Multiplex I/O line ABS system Airbag system Audio system Navigation system Smart sensor & actuator Ignition circuit Motor control boards
		Secondary phone line	Printer & Scanner Paper feeders Key pads Opto sensors	Portable equipment Camcorder Cassette player CD player MD player Digital camera PDAs	
		Data line connection	Hard disc drive Vcc protection		
		Line card	FAX / MODEM		
		Fax machine	Note book computer LCD display Audio card Keyboard I/O ports Charger PCMCIA cards		

PACKAGE SPECIFICATION

Carrier tape Specification

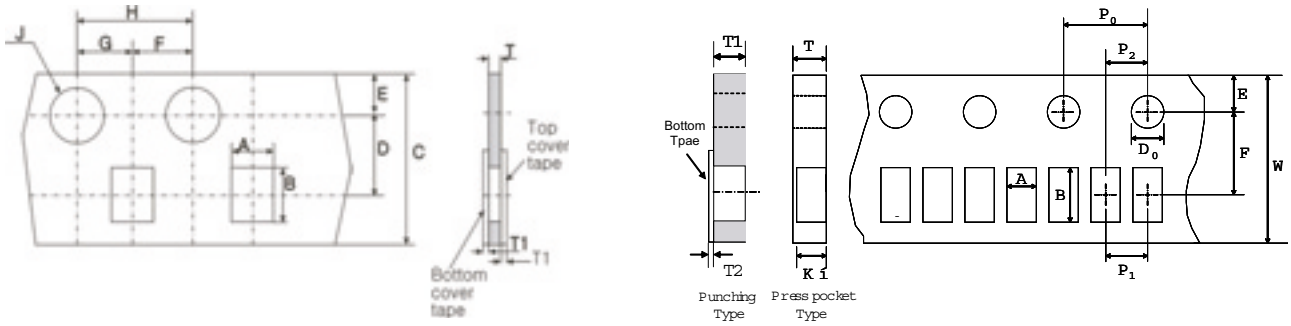

Type	A	B	C	D	E	F	G	H	J	T	T1
0402 (1005)	0.62	1.12	8	3.5	1.75	2	2	4	1.5	0.6	0.1
0603 (1608)	1	1.9	8	3.5	1.8	2	2	4	1.55	0.95	0.1
0805 (2012)	1.55	2.3	8	3.5	1.75	2	2	4	1.55	0.68	0.1

Type	A	B	D0	E	F	P0	P1	P2	W	K'	T	T1	T2
0603 (0201)	0.62	1.12	1.55	1.75	3.5	4	2	2	8	0.6	0.65	0.6	0.1
1005 SF	0.62	1.12	1.55	1.75	3.5	4	2	2	8	0.6	0.48	0.43	0.1
1005 SR	0.62	1.12	1.55	1.75	3.5	4	2	2	8	0.6	0.48	0.43	0.1

Reel Specification

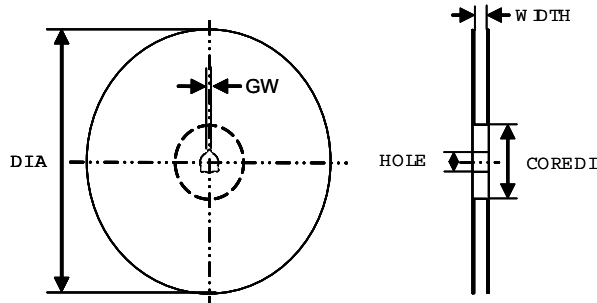

ITEM	DIA	WIDTH	CORE DIA	HOLE	GW
SIZE	178.0±0.5	9.0±0.5	60.0±1.0	13.2±0.3	2±0.3

Label adherence and winding direction

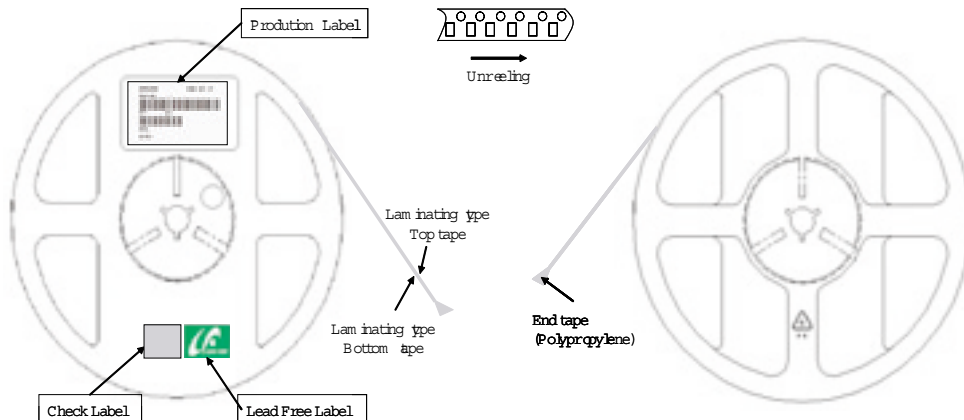

SOLDERING RECOMMENDATION

Sn/Pb Solder paste

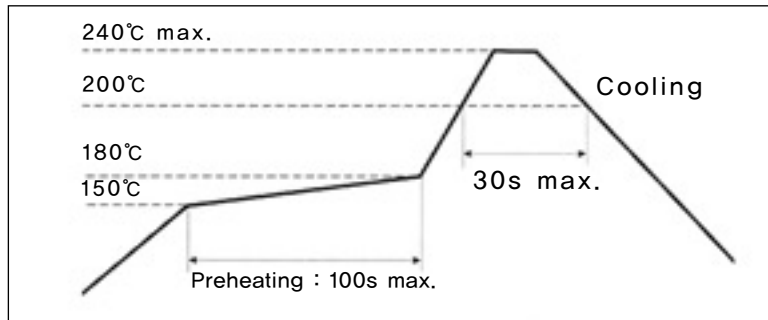

Pb free Solder paste

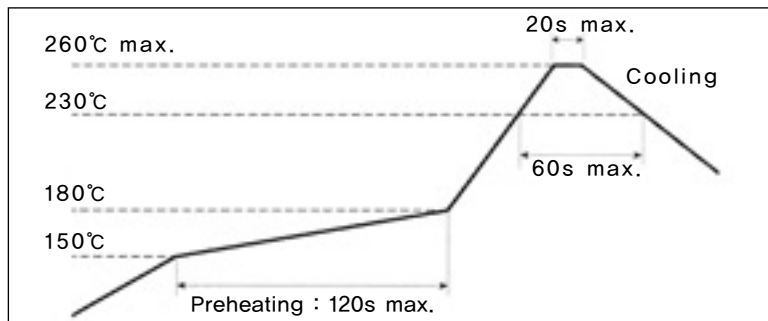

○ **Repair soldering**

Allowable time and temperature for making correction with a soldering iron : $350 \pm 10^{\circ}\text{C}$, 3 sec.

Optimum solder amount when corrections are made using a soldering iron

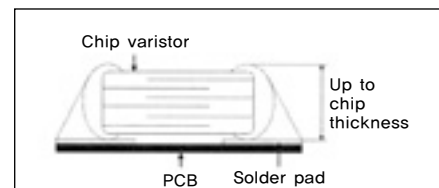

○ **Soldering Guidelines**

- Our chip varistors are designed for reflow soldering only. Do not use flow soldering
- Use Sn/Pb/Ag(62/36/2) or equivalent solder.
- Use non-activated flux(Cl content 0.2% max.)
- Follow the recommended soldering conditions to avoid varistor damage

○ **Storage Recommendation**

The components should be used within 6 months. They are to be left in the original package in order to avoid soldering problems caused by oxidized terminals. Air humidity should be less than 40%.

TYPICAL CIRCUITS REQUIRING PROTECTION

Home Appliance

DSC & Settop Box protection

- Digital Part
 - HDMI/DVI protection
 - RGB protection
 - Memory Card protection
 - USB protection
- Analog Part
 - A/V Io protection
 - S-Video protection

Mobile Phone Protection

Speaker Jack protection
Power Supply protection
Button protection
Data Interface protection
LCD Data Line & Module protection
Antenna Switching Module protection
Module protection
Speaker protection in LCD Module
Key Pad LED protection
USB Interface protection

Notebook & Desktop Computer Protection

LCD protection
Audio Circuit protection
Keyboard protection
I/O port protection

Semiconductor Device Protection

ASIC protection
IC protection
MOSFET protection

Micro Controllers Relays

CMOS relay driver
LM319 relay driver

Sensor Protection

Typical sensor protection
Hall device protection

Preamplifier Protection

Preamplifier protection
Laser Diode protection

DIGITAL TV



Antenna
ASES 12U 02 OR2
ASES 12U 03 OR2

Touch Key
ASES 12U 02 OR2

HDMI/DVI Interface

ASES 12U 02 OR2
ASES 12U 03 OR2
AMES 12U 05 Q OR2

RGB Interface

ADUC 10S 03 010
ADUC 30S 03 010
ADLC 10S 03 015

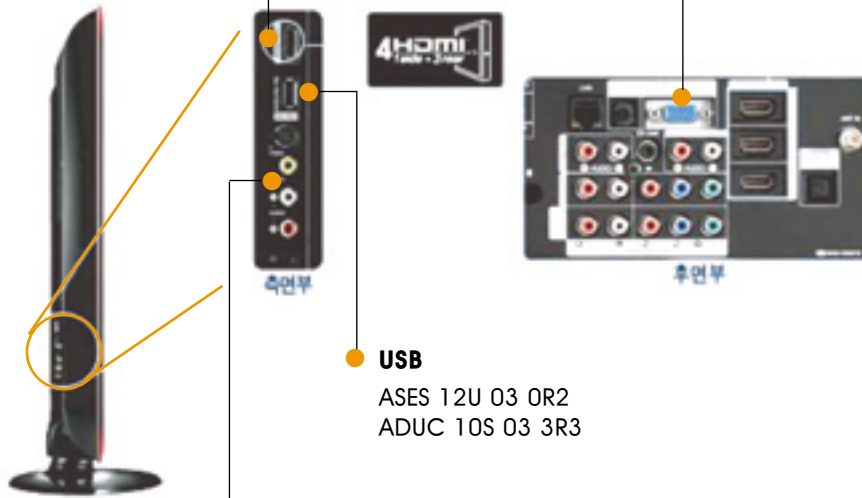

USB
ASES 12U 03 OR2
ADUC 10S 03 3R3

**A/V IO
S-Video
Component**
General Varistor

APPLICATIONS

NOTE BOOK

Antenna
ASES 12U 03 OR2
ASES 12U 02 OR2

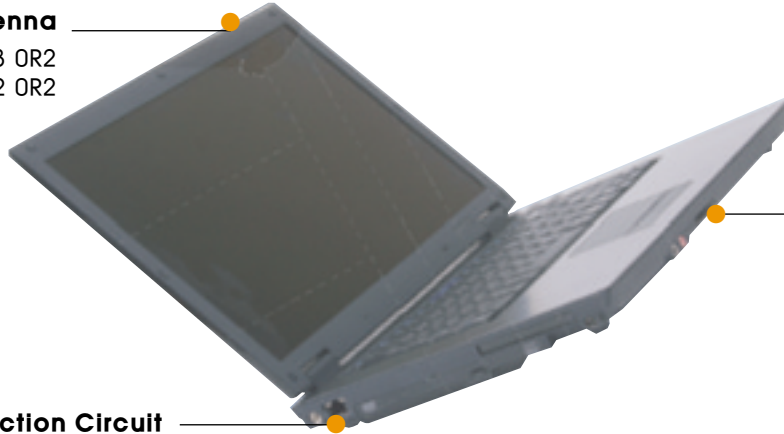

Memory Card
ASES 12U 03 OR2
ASES 12U 02 OR2
ADUC 10S 03 1R1
ADUC 10S 03 1R5

Ethernet Protection Circuit
ASES 12U 03 OR2
ASES 12U 02 OR2

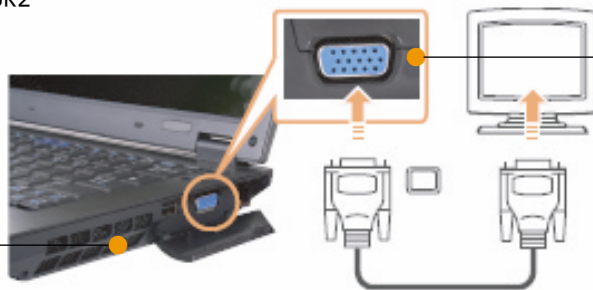

RGB
ASES 12U 02 OR2
ASES 12U 03 OR2
AMES 12U 05 Q OR2

USB
ASES 12U 03 OR2
ADUC 10S 03 3R3

DIGITAL CAMERA

EHDMI/DVI
ASES 12U 03 OR2
ASES 12U 02 OR2
ADUC 10S 03 1R1
ADUC 10S 03 1R5



Memory Card
ASES 12U 03 OR2
ASES 12U 02 OR2
ADUC 10S 03 1R1
ADUC 10S 03 1R5

USB
ASES 12U 03 OR2
ADUC 10S 03 3R3

General Date Line
AVRC 14S 03Q 030 100R
AVRC 14S 05Q 030 100R

APPLICATIONS



Home Appliance

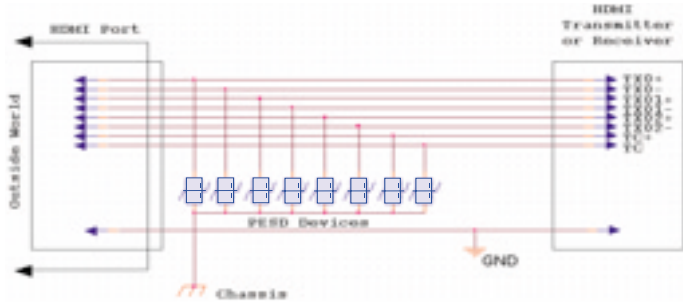

HDMI Line Protection Circuit



ASES 12U 02 0R2
ASES 12U 03 0R2

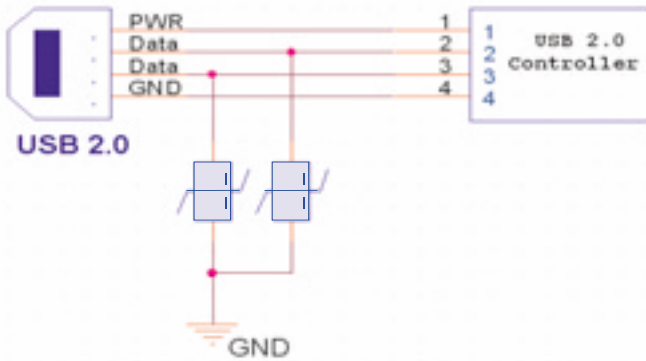

USB Interface Protection Circuit



ASES 12U 02 0R2
ASES 12U 03 0R2

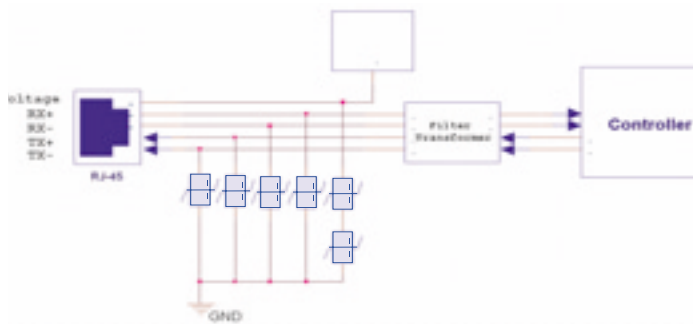

Ethernet Protection Circuit



ASES 12U 02 0R2
ASES 12U 03 0R2

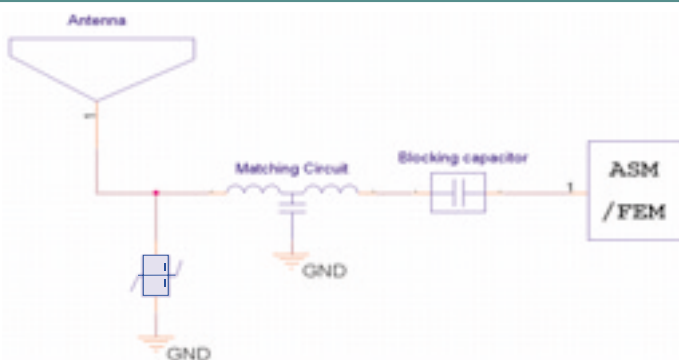

Ant. Protection Circuit



ASES 12U 02 0R2
ASES 12U 03 0R2

Mobile Phone Protection

Required characteristics of ESD Suppressors

■ Speaker jack Protection

- Rated DC Volt. : < 18V
- Energy rating : < 0.05J
- Capacitance : Concern on many designs

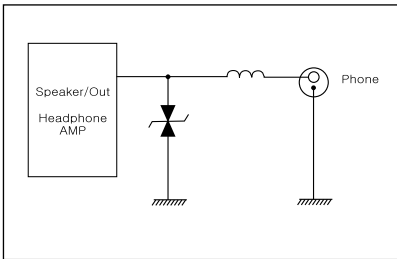

■ Power Supply Protection

- Rated DC Volt. : < 18V
- Energy rating : < 0.05J
- Capacitance : Concern on many designs

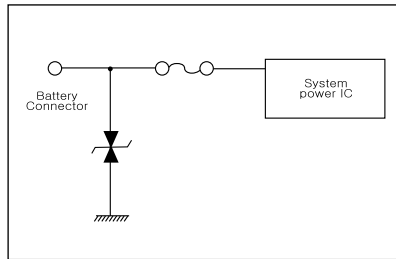

■ LCD data line & Module Protection

- Rated DC Volt. : < 18V
- Energy rating : < 0.05J
- Capacitance : Should be minimized

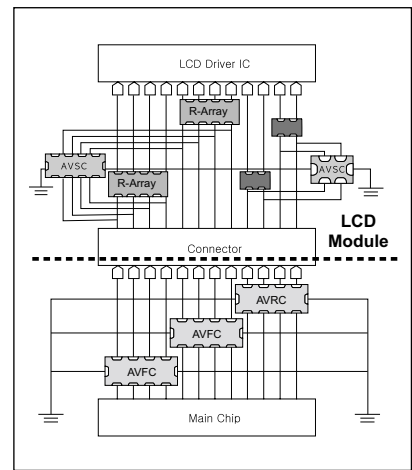

■ Button Protection

- Rated DC Volt. : < 18V
- Energy rating : < 0.05J
- Capacitance : Concern on many designs

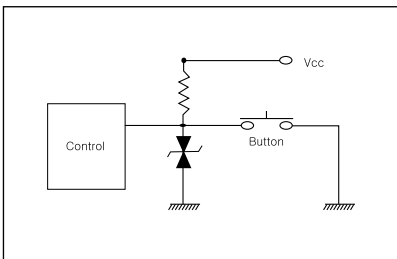

■ Data interface Protection

- Rated DC Volt. : < 18V
- Energy rating : < 0.05J
- Capacitance : Should be minimized

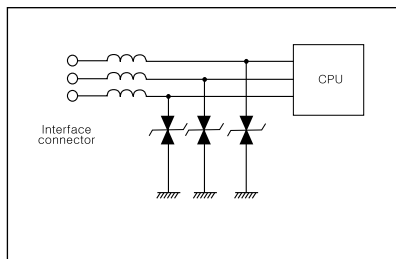

■ Antenna Switching Module Protection

- Rated DC Volt. : < 18V
- Energy rating : < 0.05J
- Capacitance : Should be minimized

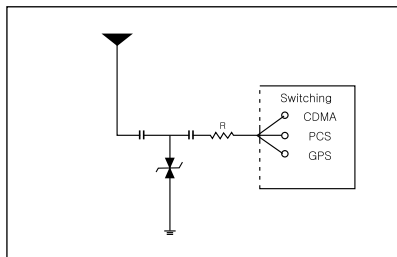

■ Module Protection

- Rated DC Volt. : < 18V
- Energy rating : < 0.1J
- Capacitance : No Concern

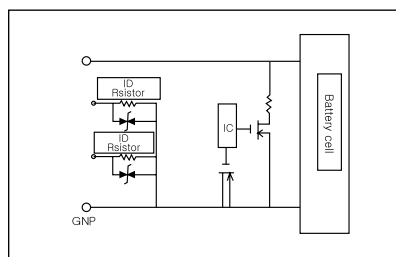

Mobile Phone Protection

Required characteristics of Transient Voltage Suppressors

■ Speaker Protection in LCD Module

- Rated DC Volt. : < 18V
- Energy rating : < 0.05J
- Capacitance : Concern on many designs

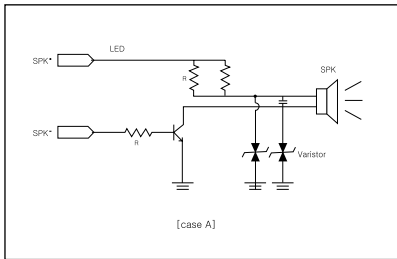

■ Key Pad LED Protection

- Rated DC Volt. : < 18V
- Energy rating : < 0.05J
- Capacitance : Concern on many designs

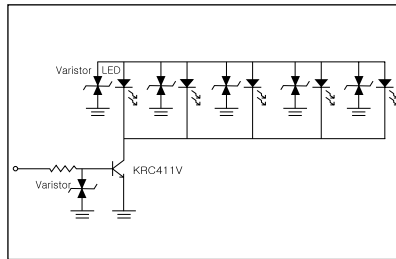

■ USB Interface Protection

- Rated DC Volt. : < 18V
- Energy rating : < 0.05J
- Capacitance : Depend on data transmission rate

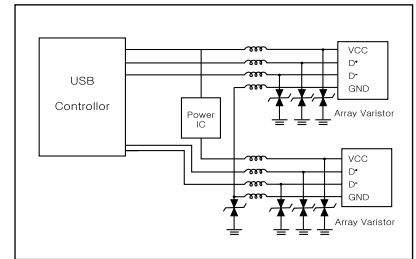

Notebook & Desktop Computer Protection

Required characteristics of Transient Voltage Suppressors

■ LCD Protection

- Rated DC Volt. : < 5.6V
- Energy rating : < 0.1J
- Capacitance : Preferred to be minimum

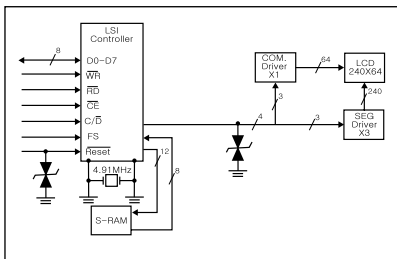

■ Audio Circuit Protection

- Rated DC Volt. : 14V – 18V
- Energy rating : Typically 0.1J
- Capacitance : No concern

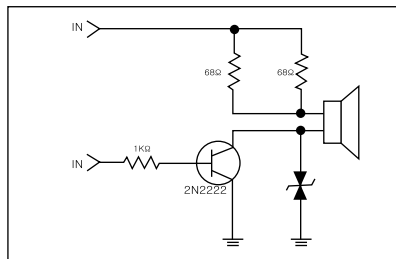

■ Keyboard Protection

- Rated DC Volt. : > 5.6V
- Energy rating : < 0.4J
- Capacitance : Preferred to be minimum

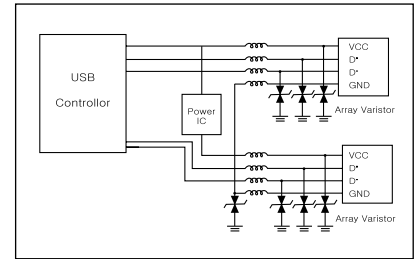

■ I/O Port Protection

- Rated DC Volt. : 14V – 18V
- Energy rating : Typically 0.05J – 0.1J
- Capacitance : Should be minimized

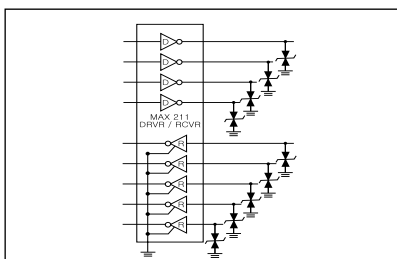

Semiconductor Device Protection

■ ASIC Protection

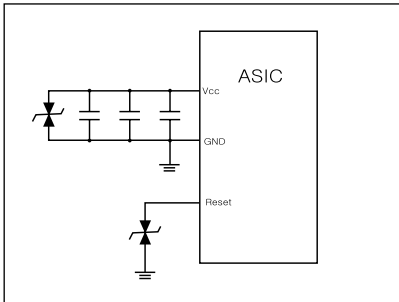

■ IC Protection

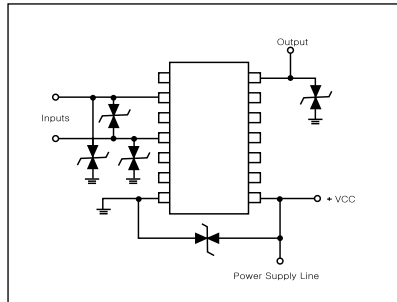

■ MOSFET Protection

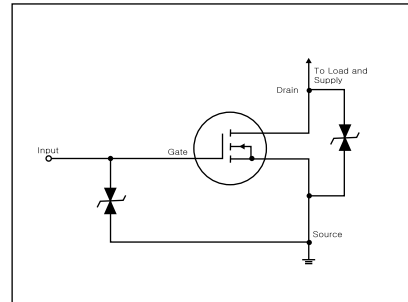

Micro Controllers Relays/Sensor Protection

Required characteristics of Transient Voltage Suppressors

■ CMOS Relay Drivers

- Rated DC Volt. : \geq Relay voltage
- Energy rating : Typically $> 0.3J$
- Capacitance : No concern

■ LM319 Relay Driver

- Rated DC Volt. : \geq Relay voltage
- Energy rating : Typically $> 0.3J$
- Capacitance : No concern

■ Typical Sensor Protection

- Rated DC Volt. : Typically $> 14V$
- Energy rating : Typically $> 0.4J$
- Capacitance : No concern

■ Hall Device Protection

- Rated DC Volt. : \geq Control voltage
- Energy rating : Typically $> 0.3J$
- Capacitance : No concern

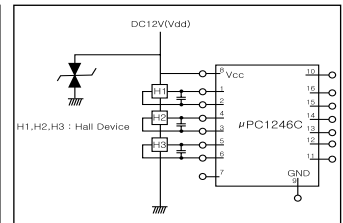
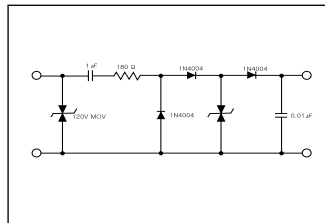
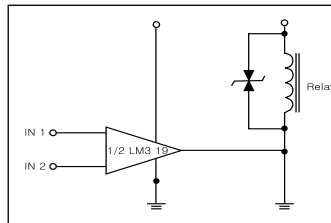
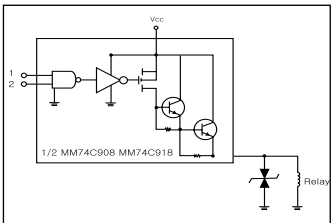

Preamplifier/Optics Protection

Required characteristics of Transient Voltage Suppressors

■ Preamplifier Protection

- Rated DC Volt. : Typically 18V – 26V
- Energy rating : 0.05J – 0.9J
- Capacitance : Concern on many designs

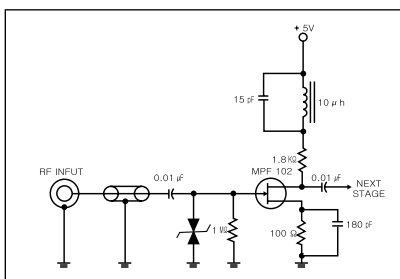

■ Laser Diode Protection

- Rated DC Volt. : $\geq 18V$
- Energy rating : 0.1J
- Capacitance : Should be minimized

