

CORNING



Microwave Gilbert[®] Push-on
Interconnects

Table of Contents

Table of Contents

Connect to Precision and Performance	4
Custom Designs	5
Corning Optical Communications RF LLC	6
Reference Guide	8
GPO® Products	10
GPO® Specifications	11
GPO Blind Mate Interconnects	12
GPO to Cable Connectors	14
GPO PCB Mounts	22
GPO Edge Mounts	26
GPO Shrouds	27
GPO Flange-Mounts	32
GPO Multiposition Blocks	35
GPO Accessories	38
GPPO® Products	41
GPPO® Specifications	42
GPPO Blind Mate Interconnects	43
GPPO to Cable Connectors	45
GPPO PCB Mounts	52
GPPO Edge Mounts	57
GPPO Shrouds	58
GPPO Flange Mounts	61
GPPO Multiposition Blocks	63
GPPO Accessories	65

G3PO™ Products	69
G3PO™ Specifications	70
G3PO Blind Mate Interconnects	71
G3PO to Cable Connectors	73
G3PO PCB Mounts	76
G3PO Edge Mounts	78
G3PO Shrouds	79
G3PO Multiposition Blocks	82
G3PO Accessories	86
G4PO™ Products	89
G4PO™ Specifications	90
G4PO Blind Mate Interconnects	91
G4PO to Cable Connectors	92
G4PO PCB Mounts	93
G4PO Edge Mounts	95
G4PO Shrouds	96
G4PO Multiposition Blocks	97
G4PO Accessories	100
Cryogenic Products	101
Cryogenic Specifications	102
Cryogenic Blind Mate Interconnects	103
Cryogenic Cable Connectors	104
Cryogenic PCB Mounts	111
Cryogenic Edge Mounts	112
Cryogenic Shrouds	113
Cryogenic Multiposition Blocks	114
Cryogenic Accessories	115
MIL-C-38999 Products	116
38999 Specifications	117
MIL-C-38999 Cable Connectors	118

Adapters 124

Adapter Matrix.....	125
GPO® Female Adapters.....	126
GPO Male Adapters.....	130
GPPO® Female Adapters.....	134
GPPO Male Adapters.....	139
G3PO™ Female Adapters.....	144
G3PO Male Adapters.....	147
G4PO™ Male Adapters.....	151

Tools 152

Installation/Removal Tools.....	153
Driver Tools.....	157
Locating Tools.....	159
Retaining Tools.....	160
Seal Locating Tools.....	161
Centering Tools.....	162
Cable Fixtures.....	163
Miscellaneous.....	164

Technical Guide 166

Test Capabilities.....	167
Custom Packaging.....	168
Introduction.....	169
Materials and Finishes.....	171
GPO.....	172
GPPO.....	176
G3PO.....	180
G4PO.....	184
Electrical – GPO, GPPO, G3PO, and G4PO.....	185
Board-to-Board Tolerance Analysis.....	187

Are you Corning connected? 192



Connect to Precision and Performance

Corning is one of the world's leading innovators in materials science. For more than 165 years, we have applied our unparalleled expertise in specialty glass, ceramics, and optical physics to develop products that have created new industries and transformed people's lives.

Our Optical Communications segment delivers connectivity to every edge of the network, from optical fiber, cable, hardware, and equipment to fully-optimized solutions for high-speed communications networks.

With over 50 years of leading-edge design experience, Corning Optical Communications RF LLC offers Gilbert® high-performance connectors used in telecommunications, test, measurement, aerospace, and defense.

ISO 9001:2015 certified

Custom Designs

To quickly design and manufacture specialized interconnects meeting unique electrical, mechanical, and environmental specifications, our expert engineers, technicians, and machinists will collaborate with you on a custom design for your application.

Our tailored design solutions include multiposition blocks, hermetic shrouds, cable connectors, PCB mounts, blind mate interconnects, loads, and adapters. Special packaging is also available, such as custom trays as well as tape and reel for automated pick and placement. Other customizable options include selective plating and solder dipping.

A typical design cycle begins with a discussion with a dedicated Corning applications engineer to understand your interconnect requirements. Our library of designs are used as a basis for assessing your needs so that your exact requirements may be met with the highest efficiency.

After receipt of order, our design engineer will create 3D CAD models which are optimized for electrical performance using electromagnetic simulation software to enable tuning for a specific frequency range or broadband performance. Complex designs may require mechanical analysis using finite element analysis software.

Complete with high-precision Swiss turning centers and CNC mills, our dedicated machine shop is equipped to produce the custom designs you need. We also maintain a plating shop for passivation or plating of metallic components. Many validation tests are performed in-house. Electrical tests include voltage standing wave ratio, dielectric withstanding voltage, and insulation resistance. Mechanical tests include durability and mating forces. Environmental tests include thermal cycling, humidity, and salt spray.

Connect with our customer care team for more information:

1-828-901-5000 (International)

800-743-2675 (United States and Canada)

ccsamericas@corning.com

www.corning.com/microwave

Corning Optical Communications RF LLC

1957



Gilbert Engineering was founded in Arizona

1990



Created the second generation push-on connector, GPPO®

1984



Developed the first push-on microwave connector, GPO®

1992



Oak Industries acquired Gilbert Engineering

2000



Corning Incorporated
acquired Gilbert
Engineering

2005

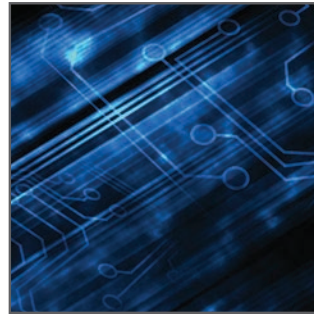

Gilbert Engineering
was integrated
into Corning Optical
Communications

2016



Invested in technology
team to enhance R&D
capabilities

2003



Created the third
generation push-on
connector, G3PO™

2010



Created the fourth
generation push-on
connector, G4PO™



Reference Guide

Symbols

CC	Center Conductor	LD	Limited Detent	RF	Radio Frequency	SQ	Square
CM	Catchers Mitt	mm	Millimeter	R/P	Reference Plane	VSWR	Voltage Standing Wave Ratio
dB	Decibel	MP	Microporous	SB	Smooth Bore	XD	Extra Deep
FD	Full Detent	PCB	Printed Circuit Board	SI	Short Interface	Ø	Diameter
GHz	Gigahertz	R/A	Right-Angle	S/R	Semi-Rigid		

Common Materials and Finishes

- Beryllium copper per ASTM B 196 and/or ASTM B 197.
Gold plate per ASTM B 488 over electrolytic nickel per SAE AMS QQ N 290.
- CRES 303 per ASTM A 484 and ASTM A 582 or ASTM A 555 and ASTM A 581. Passivate per SAE AMS 2700.
- Brass per ASTM B 16. Gold plate per ASTM B 488 over electrolytic nickel per SAE AMS QQ N 290.
- Virgin Teflon® PTFE fluorocarbon per ASTM D 1710.
- Kovar® Iron-nickel-cobalt sealing alloy per ASTM F 15.
Gold plate per ASTM B 488 over electrolytic nickel per SAE AMS QQ N 290.
- Corning® 7070 glass or equivalent.
- Ultem® 1000 (Polyetherimide) per ASTM D 5205.
- Torlon® (Polyamide-Imide) per ASTM D 5204.

Standard Tolerances

All dimensions are in inches, interpretation per ANSI Y14.5.

.XX ± .010

.XXX ± .005

Fractions ± 1/64

Angular ± 5°

Typical machine surface finish 63 micro-inches

Detent

A captivation system was developed for the GPO®, GPPO®, G3PO™ and G4PO™ interconnect systems that provides predictable levels of retention without the use of bulky coupling nuts. This feature is characterized as the connector’s detent.

The GPO product is designed with three available detent levels, and two detents exist within the smaller GPPO, G3PO and G4PO series. This is accommodated by the incorporation of a ring in the male pin connector (commonly known as the shroud). This “detent ring” interacts with the mating connector (female contact) to captivate the pair together.

Each of the detent levels, full detent, limited detent (available only in the GPO series), and smooth bore (or zero detent) provide different levels of force required to mate and demate the connectors.

	Engage*				Disengage*				Cycles*			
	GPO	GPPO	G3PO	G4PO	GPO	GPPO	G3PO	G4PO	GPO	GPPO	G3PO	G4PO
Full Detent	7.0 lbs	4.5 lbs	2.5 lbs	.65 lbs	9.0 lbs	6.5 lbs	4.5 lbs	2.2 lbs	100 min	100 min	100 min	100 min
Limited Detent	5.0 lbs	N/A	N/A	N/A	7.0 lbs	N/A	N/A	N/A	500 min	N/A	N/A	N/A
Smooth Bore	3.0 lbs	2.5 lbs	1.2 lbs	.20 lbs	0.5 lbs	1.5 lbs	1.0 lbs	.15 lbs	1,000 min	500 min	500 min	500 min

*The figures listed for the engage/disengage forces are typical and based upon actual data.

Proper care should be used when designing your system to select the required forces for engaging and disengaging. The level of detent selected will also have an impact on the number of engage/disengage cycles. Note, female cable connectors MUST be used with a full-detent male to maintain a fully mated condition during shock and vibration.



GPO® Products

- Center-to-center spacing of 0.170-in available for increased package density
- Frequency from DC to 40 GHz
- Designed to accommodate both radial and axial misalignment with negligible Voltage Standing Wave Ratio (VSWR) charge
- Commonly known as Sub-Miniature Push-On (SMP)



GPO® Specifications

General Characteristics

Impedance	50 Ohms nominal
Frequency range	DC to 40 GHz
Temperature range	-65°C to 165°C

Electrical Characteristics

VSWR	1.15:1 to 26.5 GHz typical; < 1.5:1 typical to 40 GHz
Insertion loss	.04 √f (GHz)
DWV @ sea level	500 V _{rms}
Insulation resistance	5,000 megohms minimum
Contact resistance	
Outer conductor	2 milliohms maximum
Inner conductor	6 milliohms maximum
RF leakage	-80 dB to 3 GHz, -65 dB to 26.5 GHz

Mechanical Characteristics

Mate/demate cycles	FD - 100 min, LD - 500 min, SB - 1,000 min
Force to engage/disengage	FD - 7.0 lb typ/9.0 lb typ LD - 5.0 lb typ/7.0 lb typ SB - 3.0 lb typ/0.5 lb typ
Tolerated misalignment	
Radial	+/- 0.0010
Axial	0.010 (flush to 0.010 from the reference plane)

Environmental Characteristics

Thermal shock	MIL-STD-202, Method 107, Condition B
Salt spray	MIL-STD-202, Method 101
Vibration	MIL-STD-202, Method 204
Shock	MIL-STD-202, Method 213, Condition I
Moisture resistance	MIL-STD-202, Method 106, except Step 7B

Materials (typical)

Bodies	Beryllium copper per ASTM B196 and or/ASTM B197
Outer contacts	Beryllium copper per ASTM B196 and or/ASTM B197
Center contacts	Beryllium copper per ASTM B196 and or/ASTM B197
Insulators	PTFE fluorocarbon per ASTM D1710
Springs	17-7 Stainless Steel per ASTM A313-95A

Finish (typical)

Bodies	Gold plated per MIL-G-45204, Type I, Grade C, Class 1, over nickel plate per SAE AMS-QQ-N-290
Contacts	Gold plated per MIL-G-45204, Type I, Grade C, Class 1, over nickel plate per SAE AMS-QQ-N-290

GPO® Blind Mate Interconnects

Female Blind Mate Interconnect (Bullet) Connector – Standard

Catalog Number	Length (inches)	Recommended Tools	Assembly Procedure	Notes
A1A1-0001-02	.224	A095-A99-01	-	
A1A1-0001-01	.254	A095-A99-01	-	
A1A1-0001-07	.286	A095-A99-01	-	
A1A1-0001-03	.395	A095-A99-01	-	
A1A1-0001-44	.420	A095-A99-01	-	
A1A1-0001-25	.517	A095-A99-01	-	
A1A1-0001-21	1.000	A095-A99-01	-	
A1A1-0001-42	1.471	A095-A99-01	-	

*Many more bullet lengths are available upon request. Contact for details.

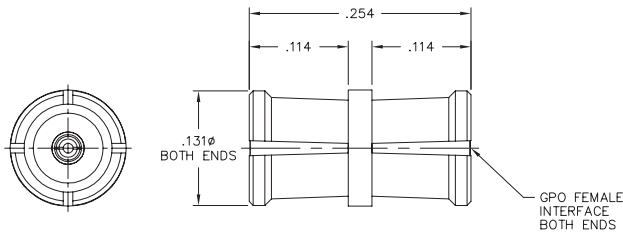

A1A1-0001-01



A1A1-0001-01



A1A1-0001-25

Female Blind Mate Interconnect (Bullet) Connector – Alignment Features

Catalog Number	Length (inches)	Recommended Tools	Assembly Procedure	Notes
A1A1-0001-35	.621	A095-A99-01	-	Gasket included
A1A1-0001-24	.651	A095-A99-01	-	Gasket included
A1A1-0001-71-1856	1.856	A095-A99-01	-	Gasket included

*O-rings and gaskets are for alignment only and are not to be used for shielding applications.

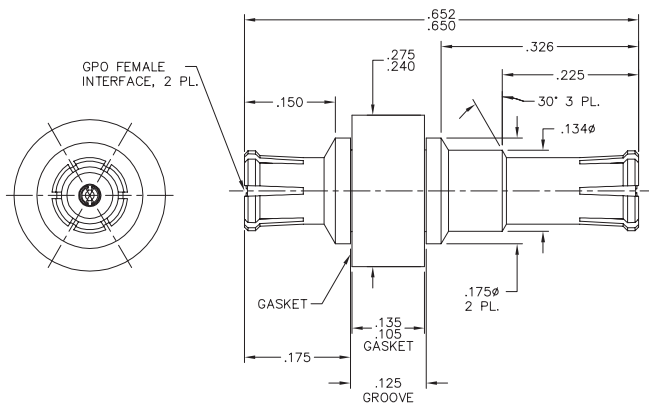

A1A1-0001-24



Front: A1A1-0001-24



Back: A1A1-0001-24

GPO® Blind Mate Interconnects

Female Blind Mate Interconnect (Bullet) Connector – Spring Loaded/Self-Adjusting

Catalog Number	Relaxed Length (inches)	Compressed Length (inches)	Recommended Tools	Assembly Procedure	Notes
A1A1-0001-09	.675	.600	A095-A99-01	-	
A1A1-0001-34	.777	.702	A095-A99-01	-	
A1A1-0009-04	.806	.731	A095-A99-01	-	
A1A1-0009-08	.840	.765	A095-A99-01	-	
A1A1-0009-05	1.001	.926	A095-A99-01	-	
A1A1-0009-01	1.470	1.395	A095-A99-01	-	
A1A1-0009-06	2.259	2.184	A095-A99-01	-	

*O-rings and gaskets are for alignment only and are not to be used for shielding applications.

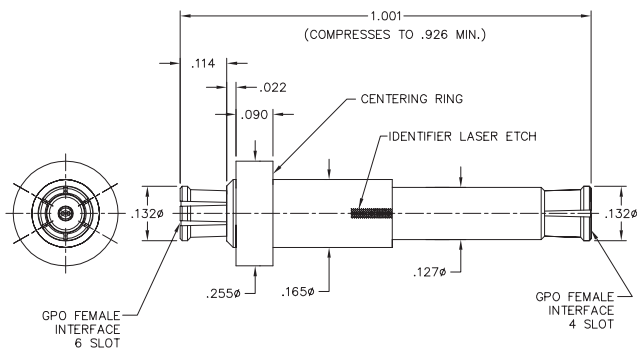

A1A1-0009-05



Front: A1A1-0009-05



Back: A1A1-0009-05

GPO® to .047 Cable Connectors

Female Straight to .047 Semi-Rigid (S/R) Cable

Catalog Number	Recommended Tools	Assembly Procedure	Notes
A014-B11-01	A098-A98-08/A098-A99-10/A098-A99-02, A096-A99-02, A096-A99-06, L096-A99-02	AP01-002	

*Semi-flex cable can be substituted in place of .047 semi-rigid.
 **Additional cable options for GPO® female straight connectors are available.

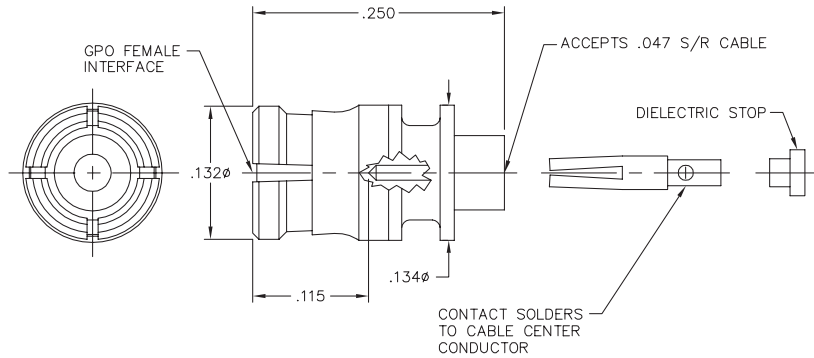

A014-B11-01

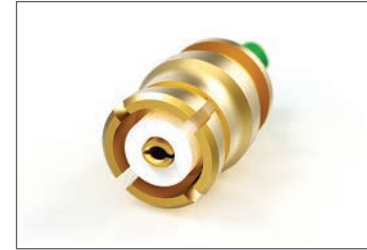

A014-B11-01

Female Right-Angle (R/A) to .047 Semi-Rigid (S/R) Cable

Catalog Number	Recommended Tools	Assembly Procedure	Notes
A015-B11-01	A096-A99-01, A096-A99-07, L096-A99-02, A098-A99-08	AP01-097	
A015-B11-02	A096-A99-01, A096-A99-07, L096-A99-02, A098-A99-08	AP01-097	
A015-B71-03	A096-A99-01, A096-A99-02, L096-A99-02, A098-A99-08	AP01-073	Swept contact

*Semi-flex cable can be substituted in place of .047 semi-rigid.
 **Additional cable options for GPO female right-angle connectors are available.

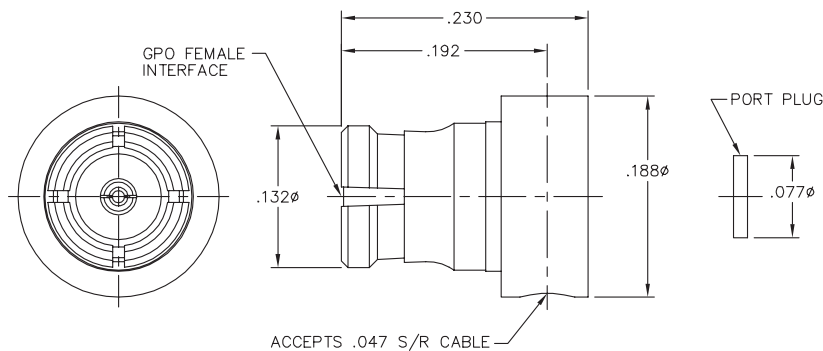

A015-B11-01



A015-B11-01

GPO® to .047 Cable Connectors

Male Flange-Mount to .047 Semi-Rigid (S/R) Cable

Catalog Number	Recommended Tools	Assembly Procedure	Notes
A001-B8X-01	A096-A99-03, A096-A99-04, L096-A99-02	AP01-014	Flange diameter \varnothing .480 Flange width .188 Hole spacing .328 Hole size \varnothing .093
A001-B8X-02	A096-A99-03, A096-A99-04, L096-A99-02	AP01-014	Flange diameter \varnothing .400 Flange width .188 Hole spacing .282 Hole size \varnothing .073

*Semi-flex cable can be substituted in place of .047 semi-rigid.
**Additional cable options for GPO® male flange-mount connectors are available.

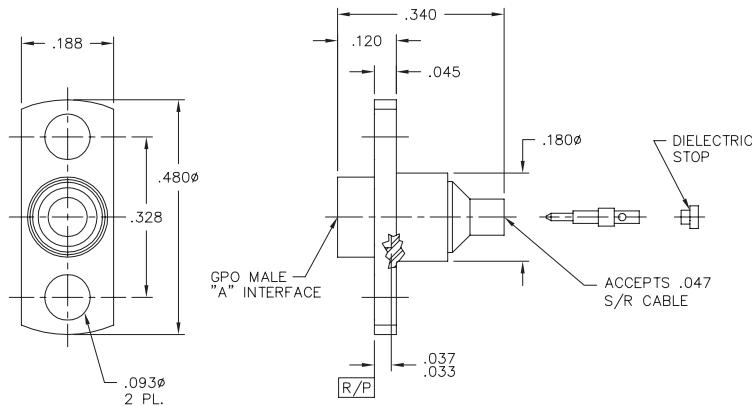

A001-B8X-01



A001-B8X-01

Male Bulkhead to .047 Semi-Rigid (S/R) Cable

Catalog Number	Recommended Tools	Assembly Procedure	Notes
A016-B8X-01	A096-A99-03, A096-A99-04, Fixture OSI Model No. T-4567, A097-A99-04 (FD)/A097-A99-05 (LD)/A097-A99-06 (SB)	AP01-063	
A016-B85-04	A096-A99-03, A096-A99-04, Fixture OMNI Model No. T-4567, A097-A99-04	AP01-023	

*Semi-flex cable can be substituted in place of .047 semi-rigid.
**Additional cable options for GPO male bulkhead connectors are available.

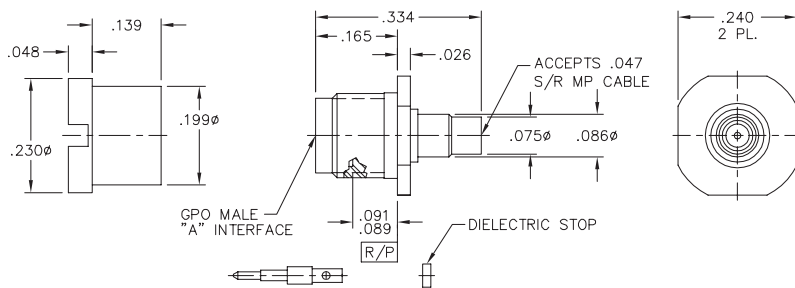

A016-B8X-01



A016-B8X-01

GPO® to .047 Cable Connectors

Female Snap-In to .047 Semi-Rigid (S/R) Cable

Catalog Number	Recommended Tools	Assembly Procedure	Notes
A018-B71-01	A096-A99-02, A096-A99-06, L096-A99-02, A098-A99-05	IS-7822-1	
A018-B71-02	A096-A99-02, A096-A99-06, L096-A99-02, A098-A99-05	IS-7822-1	

*Semi-flex cable can be substituted in place of .047 semi-rigid.
 **Additional cable options for GPO® female snap-in connectors are available.

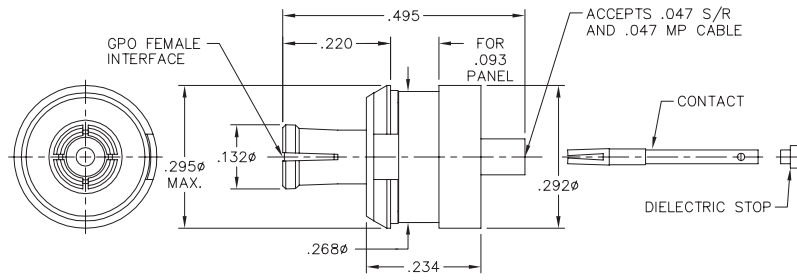

A018-B71-01



A018-B71-01

Female Straight to .086 Semi-Rigid (S/R) Cable

Catalog Number	Recommended Tools	Assembly Procedure	Notes
A014-D11-01	A098-A98-08/A098-A99-10/A098-A99-02, A096-A99-06, L096-A99-01	AP01-114	Includes anti-rock/EMI ring
A014-D71-01	A098-A98-08/A098-A99-10/A098-A99-02	-	Includes anti-rock/EMI ring

*Semi-flex cable can be substituted in place of .086 semi-rigid.
 **Additional cable options for GPO female straight connectors are available.

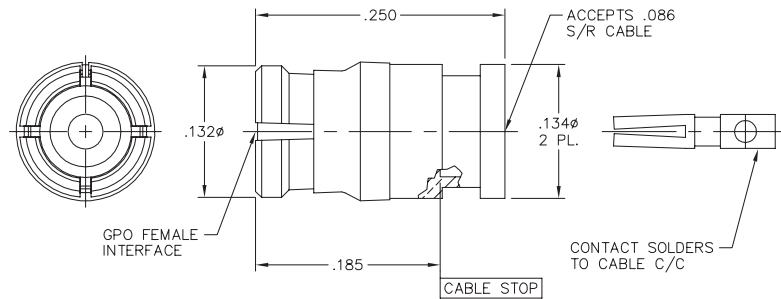

A014-D11-01



A014-D11-01

GPO® to .086 Cable Connectors

Female Right-Angle (R/A) to .086 Semi-Rigid (S/R) Cable

Catalog Number	Recommended Tools	Assembly Procedure	Notes
A015-D11-01	A096-A99-01, A096-A99-07, L096-A99-01	AP01-115	
A015-D11-03	A096-A99-01, A096-A99-07, L096-A99-01	AP01-072	Swept contact

*Semi-flex cable can be substituted in place of .086 semi-rigid.
 **Additional cable options for GPO® female right-angle connectors are available.

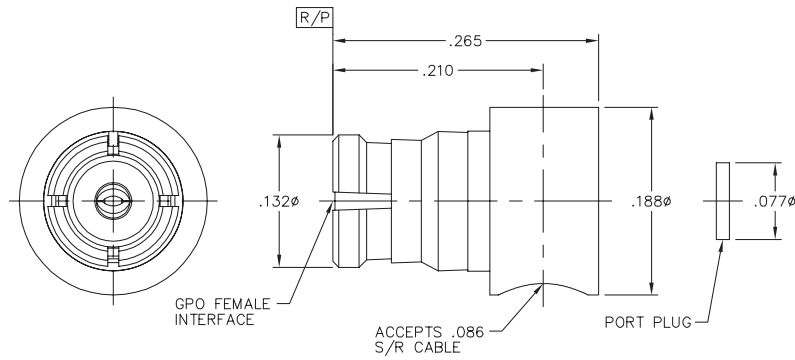

A015-D11-01



A015-D11-01

Male Right-Angle (R/A) to .086 Semi-Rigid (S/R) Cable

Catalog Number	Recommended Tools	Assembly Procedure	Notes
A015-D3X-04	A096-A99-04	AP01-038	Mirror of A015-D3X-04
A015-D3X-05	A096-A99-04	AP01-038	Mirror of A015-D3X-05

*Semi-flex cable can be substituted in place of .086 semi-rigid.
 **Additional cable options for GPO right-angle connectors are available.

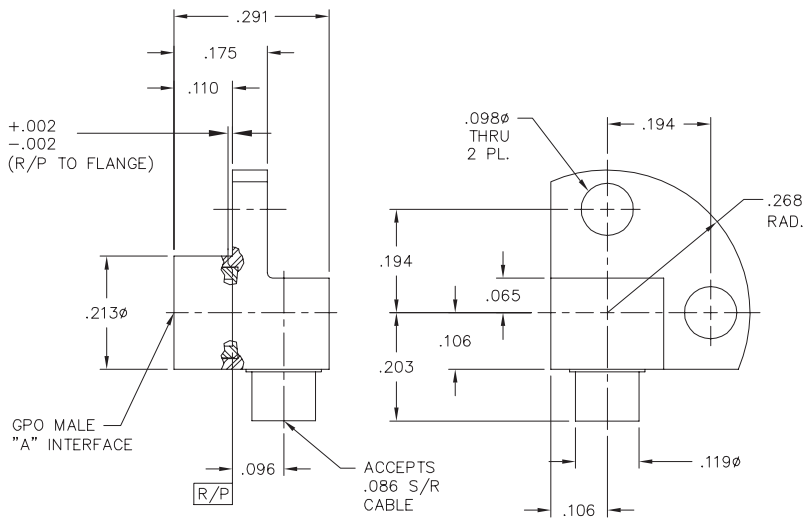

A015-D3X-05



A015-D3X-05

GPO® to .086 Cable Connectors

Male Flange-Mount to .086 Semi-Rigid (S/R) Cable

Catalog Number	Recommended Tools	Assembly Procedure	Notes
A001-D8X-01	A096-A99-03, A099-A99-04, L096-A99-01	AP01-015	Flange diameter \varnothing .480 Flange width .188 Hole spacing .328 Hole size \varnothing .093
A001-D8X-02	A096-A99-03, A099-A99-04, L096-A99-01	AP01-015	Flange diameter \varnothing .400 Flange width .188 Hole spacing .282 Hole size \varnothing .073
A014-D8X-03	A096-A99-03, A096-A99-04, OSI Model No. T-4567	IS-7051-9	Flange height .403 Flange width .188 Hole size \varnothing .093

*Semi-flex cable can be substituted in place of .086 semi-rigid.
**Additional cable options for GPO® male flange connectors are available.

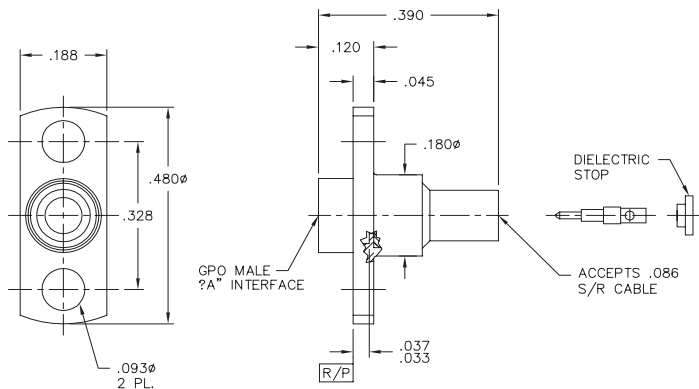

A001-D8X-01



A001-D8X-01

Male Bulkhead to .086 Semi-Rigid (S/R) Cable

Catalog Number	Recommended Tools	Assembly Procedure	Notes
A016-D7X-03	9001-932-3, A096-A99-02, A096-A99-03, L096-A99-01	AP01-123	
A016-D8X-01	A096-A99-02, A096-A99-03, OSI Model No. T-4567	AP01-050	

*Semi-flex cable can be substituted in place of .086 semi-rigid.
**Additional cable options for GPO male bulkhead connectors are available.

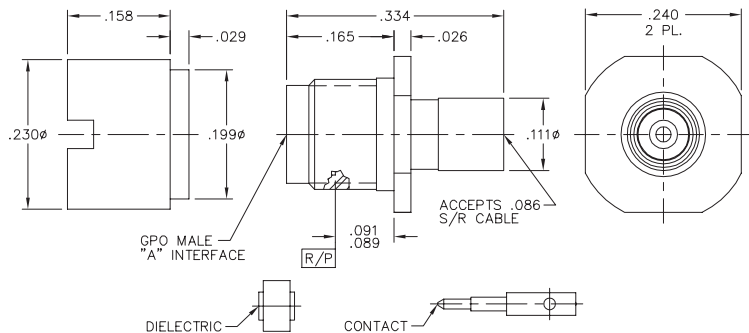

A016-D7X-03

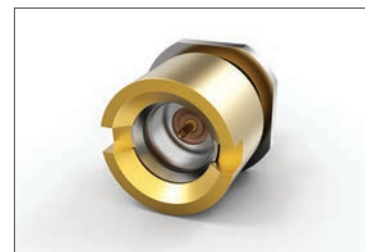

A016-D7X-03

GPO® to .086 Cable Connectors

Female Snap-In to .086 Semi-Rigid (S/R) Cable

Catalog Number	Recommended Tools	Assembly Procedure	Notes
A014-D11-06	A096-A99-02, A096-A99-06, L096-A99-01, L096-A99-04, 9001-984-0, 9160-107-3	-	
A018-D11-01	A096-A99-02, A096-A99-06, L096-A99-01, L096-A99-04, 9001-984-0, 9160-107-3	IS-7504-1	

*Semi-flex cable can be substituted in place of .086 semi-rigid.
 **Additional cable options for GPO® female snap-in connectors are available.

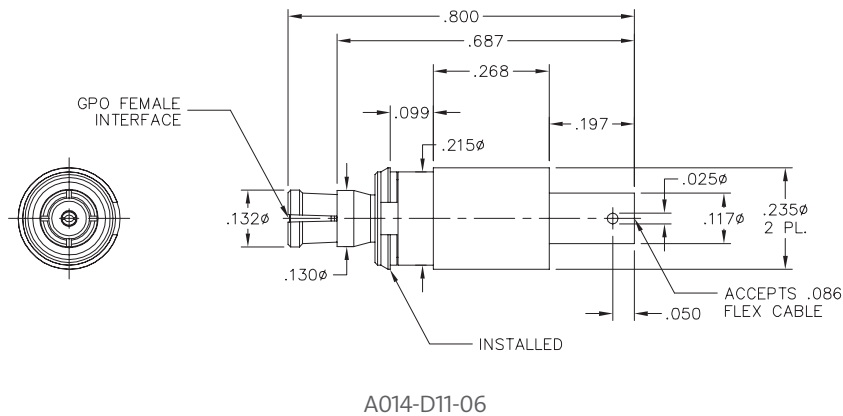

A014-D11-06

Male Snap-In to .086 Semi-Rigid (S/R) Cable

Catalog Number	Recommended Tools	Assembly Procedure	Notes
A016-D5X-01	A096-A99-03, L096-A99-01, L096-A99-04	AP01-087	

*Semi-flex cable can be substituted in place of .086 semi-rigid.
 **Additional cable options for GPO male snap-in connectors are available.

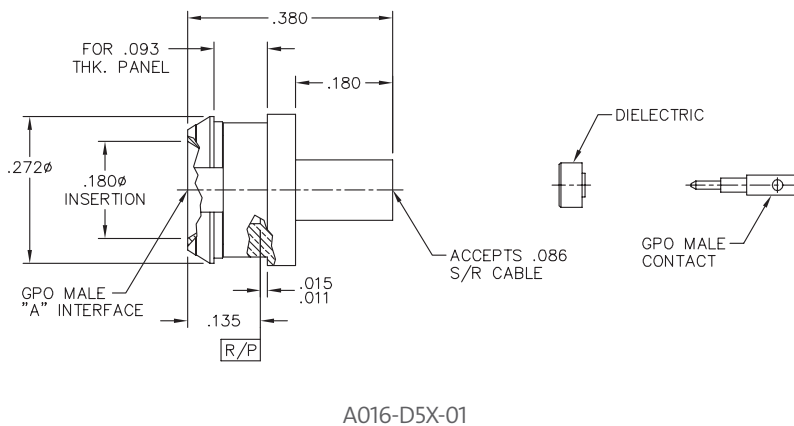

A016-D5X-01

GPO® to .141 Cable Connectors

Female Straight to .141 Semi-Rigid (S/R) Cable

Catalog Number	Recommended Tools	Assembly Procedure	Notes
A014-R11-01	L096-A99-05, T-4700-1, A096-A99-06	IS-7481-1	

*Semi-flex cable can be substituted in place of .141 semi-rigid.

**Additional cable options for GPO® female straight connectors are available.

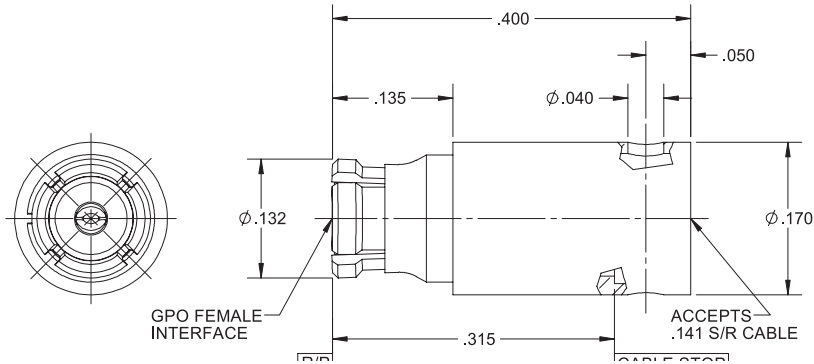

A014-R11-01



A014-R11-01

Male Flange-Mount to .141 Semi-Rigid (S/R) Cable

Catalog Number	Recommended Tools	Assembly Procedure	Notes
A014-R3X-01	-	-	

*Semi-flex cable can be substituted in place of .141 semi-rigid.

**Additional cable options for GPO male flange connectors are available.

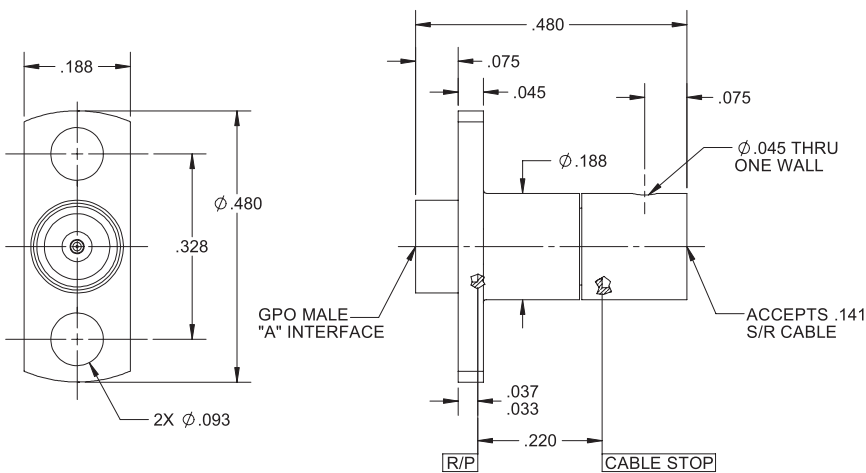

A014-R3X-01



A014-R3X-01

GPO® to .141 Cable Connectors

Male Snap-In to .141 Semi-Rigid (S/R) Cable

Catalog Number	Recommended Tools	Assembly Procedure	Notes
A018-R96-01	-	AP01-151	

*Semi-flex cable can be substituted in place of .141 semi-rigid.

**Additional cable options for GPO® male snap-in connectors are available.

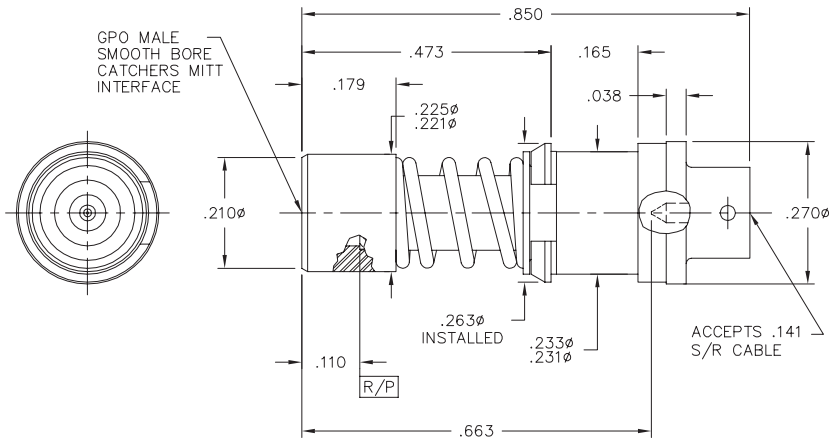

A018-R96-01



A018-R96-01

GPO® Vertical Launch PCB Mounts

Male Straight to PCB, Square Body

Catalog Number	Recommended Tools	Assembly Procedure	Notes
A008-L1X-01	-	-	.140 leg length
A008-L1X-03	-	-	.100 leg length

*Additional leg length, body styles, and packaging options for GPO® male straight to PCB connectors are available.

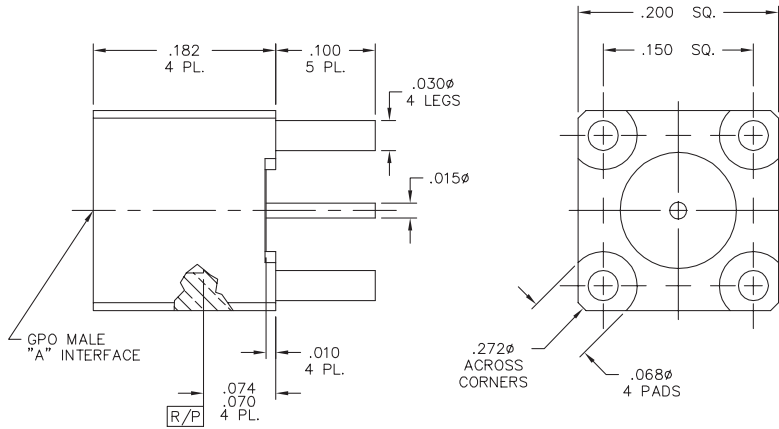

A008-L1X-03

A008-L1X-03

Male Straight to PCB, Round Body

Catalog Number	Recommended Tools	Assembly Procedure	Notes
A008-L3X-01	-	-	.100 leg length
A008-L3X-01-T	-	-	.100 leg length, solder dipped
A008-L3X-01-T @T13	-	-	.100 leg length, solder dipped, on tape and reel
A008-L3X-02	-	-	.140 leg length
A008-L3X-02-T	-	-	.140 leg length, solder dipped
A008-L3X-08	-	-	.065 leg length
A008-L3X-13-TAB-T	-	-	.025, .050, .075, .100, .125 leg length, solder dipped

*Additional leg length, body styles, and packaging options for GPO male straight to PCB connectors are available.

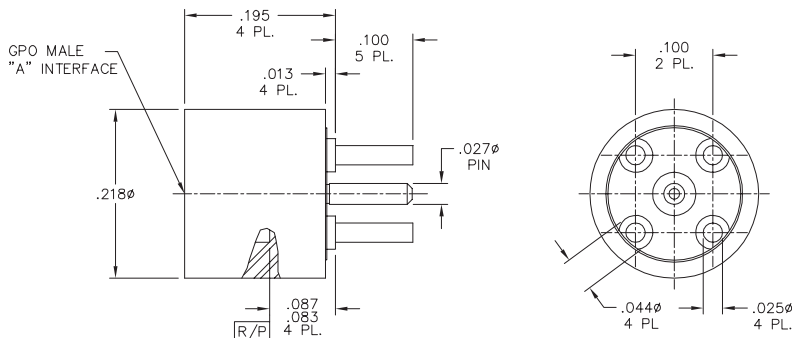

A008-L3X-01

A008-L3X-01

GPO® Vertical Launch PCB Mounts

Male Straight to PCB, Separate Center Conductor (C/C)

Catalog Number	Recommended Tools	Assembly Procedure	Notes
A008-L3X-05	-	-	.145 leg length
A008-L3X-05-T	-	-	.145 leg length, solder dipped
A008-L9X-10-TAB	-	-	.100, .125, .150, .175 leg length, alignment plug

*Additional leg length, body styles, and packaging options for GPO® male straight to PCB connectors are available.

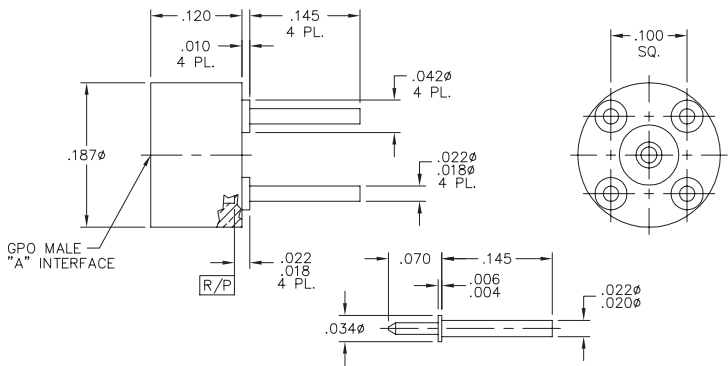

A008-L3X-05



A008-L3X-05

Male Straight to PCB, Right-Angle (R/A) Center Conductor (C/C)

Catalog Number	Recommended Tools	Assembly Procedure	Notes
A012-P9X-01	-	-	No legs
A012-P9X-01-T	-	-	No legs, solder dipped
A012-P9X-01-T @ T13	-	-	No legs, solder dipped, on tape and reel
A012-P9X-02	-	-	No legs
A012-P9X-04	-	-	.140 leg length
A012-P9X-04-T	-	-	.140 leg length, solder dipped
A012-P9X-04-T @ T13	-	-	.140 leg length, solder dipped, on tape and reel

*Additional leg length, body styles, and packaging options for GPO male straight to PCB connectors are available.

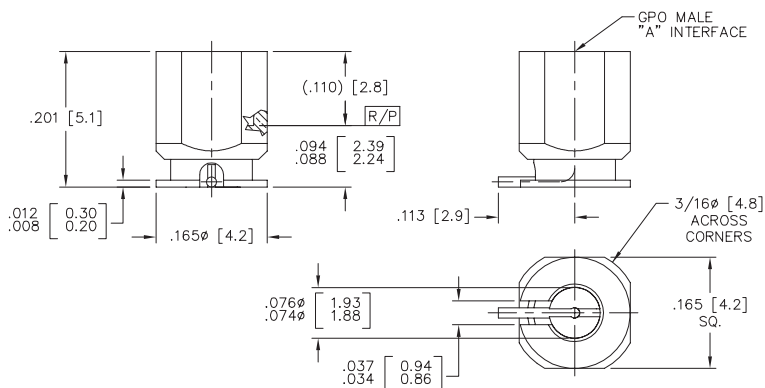

A012-P9X-01



A012-P9X-01

GPO® Vertical Launch PCB Mounts

Male Straight to PCB, Right-Angle (R/A) Center Conductor (C/C) Reverse Mount

Catalog Number	Recommended Tools	Assembly Procedure	Notes
A012-P9X-12	-	-	Reverse mount through board
A012-P9X-12-T	-	-	Reverse mount through board, solder dipped

*Additional leg length, body styles, and packaging options for GPO® male straight to PCB connectors are available.

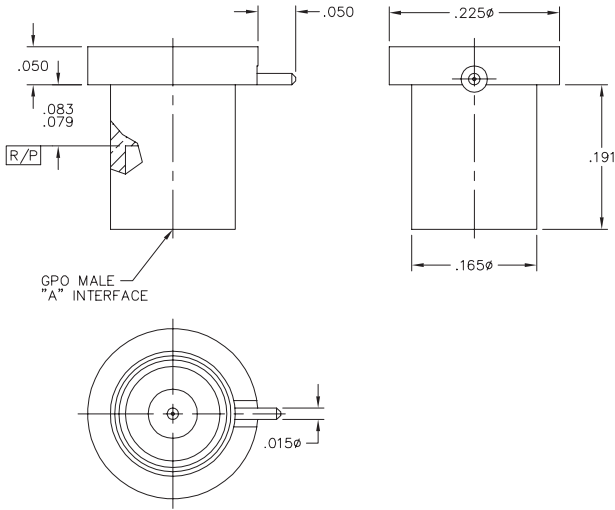

A012-P9X-12



A012-P9X-12

Male Straight to PCB, Separate Right-Angle (R/A) Center Conductor (C/C)

Catalog Number	Recommended Tools	Assembly Procedure	Notes
A008-T1X-01-T	-	-	.020 leg length (two legs), solder dipped, alignment plug
A008-P3X-01	-	-	.125 leg length
A008-P3X-01-T	-	-	.125 leg length, solder dipped

*Additional leg length, body styles, and packaging options for GPO male straight to PCB connectors are available.

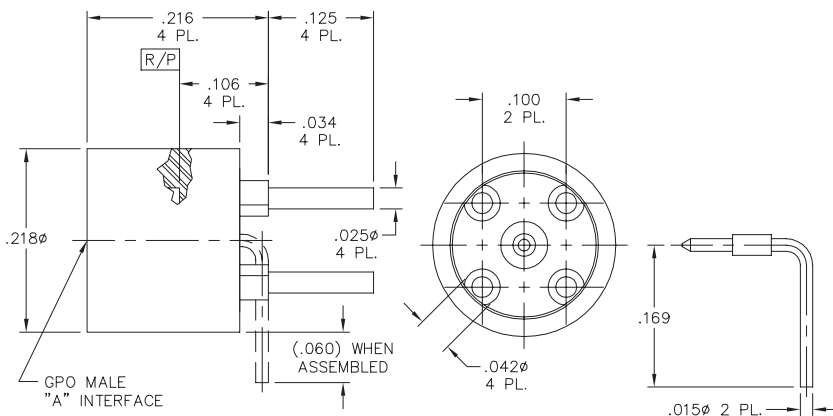

A008-P3X-01



A008-P3X-01

GPO® Right-Angle PCB Mounts

Male Right-Angle to PCB

Catalog Number	Recommended Tools	Assembly Procedure	Notes
A009-P3X-01	-	-	.096 leg length
A009-P3X-01-T	-	-	.096 leg length, solder dipped
A009-P3X-01-T @ T13	-	-	.096 leg length, solder dipped, on tape and reel
A009-P3X-03	-	-	.140 leg length
A009-P3X-03-T	-	-	.140 leg length, solder dipped
A009-P3X-03-T @ T13	-	-	.140 leg length, solder dipped, on tape and reel
A009-P9X-12-TAB-T	-	-	.025, .050, .075, .100, .125 leg length, solder dipped

*Additional leg length, body styles, and packaging options for GPO® male right-angle angle to PCB connectors are available.

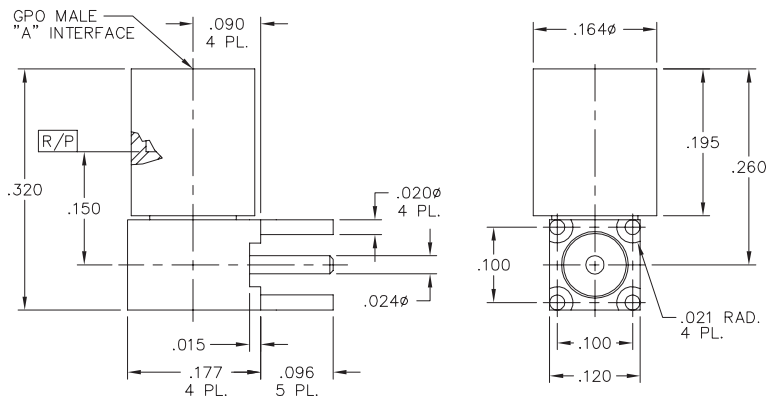

A009-P3X-01



A009-P3X-01

Male Right-Angle Z-Pin to PCB

Catalog Number	Recommended Tools	Assembly Procedure	Notes
A009-P9X-01	-	-	.190 leg length
A009-P9X-03	-	-	.150 leg length

*Additional leg length, body styles, and packaging options for GPO male right-angle to PCB connectors are available.

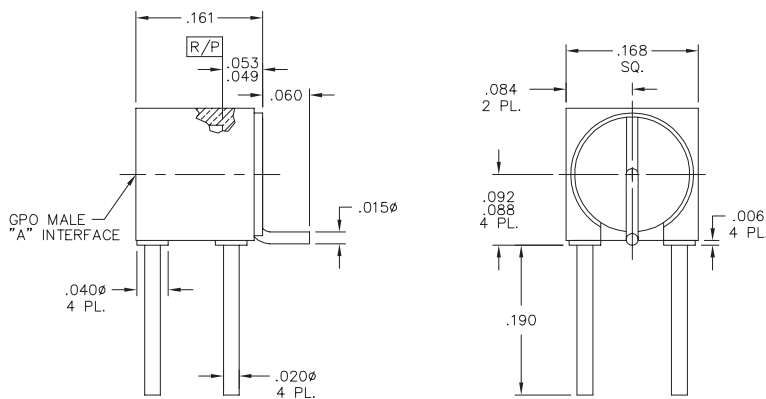

A009-P9X-01



A009-P9X-01

GPO® Edge Mounts

Male Edge Flush Mount

Catalog Number	Recommended Tools	Assembly Procedure	Notes
A010-L1X-02	-	-	
A010-L1X-02-T	-	-	Solder dipped
A010-L1X-02-T @ T13	-	-	Solder dipped, on tape and reel
A010-L16-08	-	-	
A010-L16-08-T	-	-	Solder dipped

*Additional body styles and packaging options for GPO® male edge-mount to PCB connectors are available.

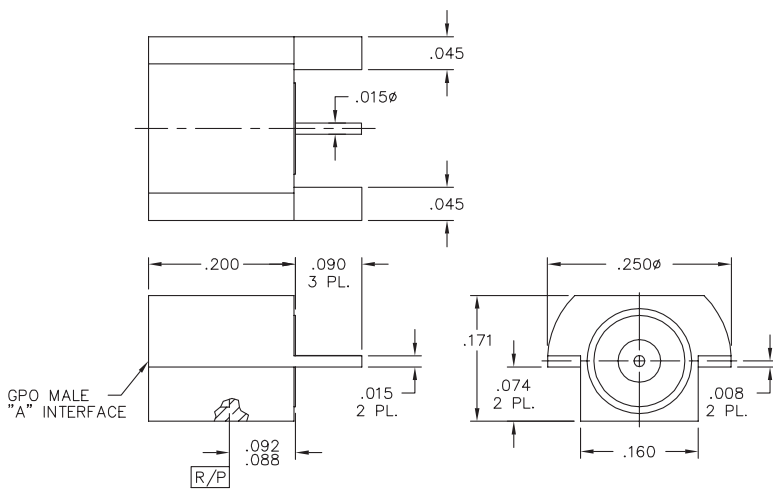

A010-L1X-02

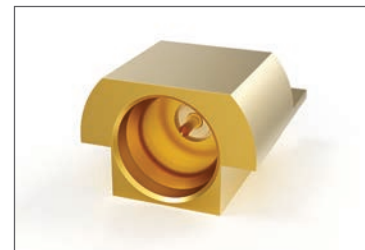

A010-L1X-02

Male Edge Mount

Catalog Number	Recommended Tools	Assembly Procedure	Notes
A010-L3X-02	-	-	

*Additional body styles and packaging options for GPO male edge-mount to PCB connectors are available.

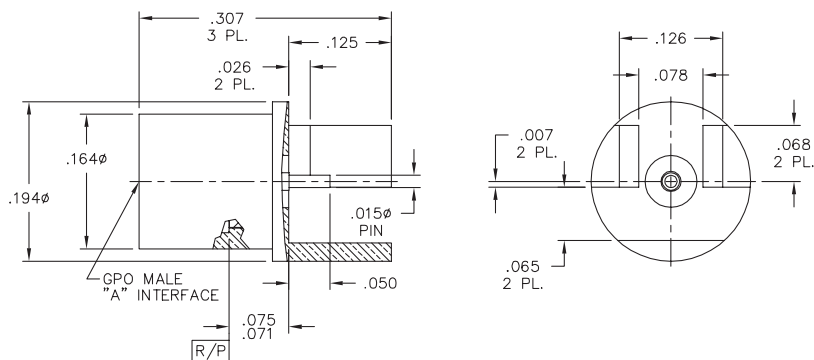

A010-L3X-02



A010-L3X-02

GPO® Thread-In Shrouds

Male Thread-In Shroud (No Pin)

Catalog Number	Recommended Tools	Assembly Procedure	Notes
A003-A2X-01	L091-A99-01, L091-A99-02, A090-A99-01, A097-A99-01 (FD), A097-A99-02 (LD), A097-A99-03 (SB)	AP01-024	

*Additional body styles and packaging options for GPO® thread-in connectors are available.

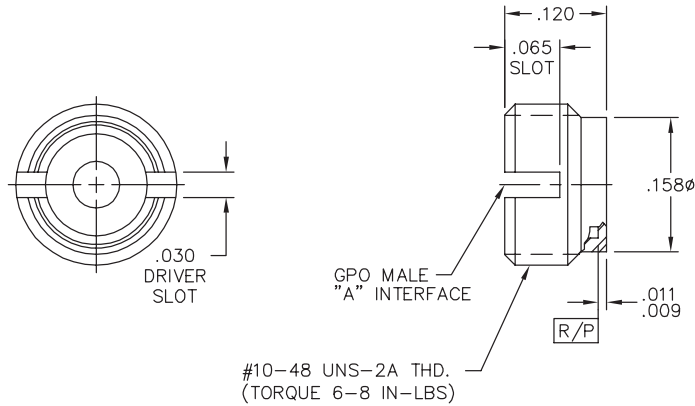

A003-A2X-01



A003-A2X-01

Male Thread-In Shroud (With Pin)

Catalog Number	Recommended Tools	Assembly Procedure	Notes
A003-L3X-01	A097-A99-01 (FD), A097-A99-02 (LD), A097-A99-03 (SB)	-	.080 pin length
A003-L3X-02	L091-A99-01, L091-A99-02, A090-A99-01, A097-A99-01 (FD), A097-A99-02 (LD), A097-A99-03 (SB)	-	.065 pin length
A007-L43-14	-	-	.100 pin length, hermetic
A003-L9X-02	L091-A99-01, L091-A99-02, A090-A99-01, A097-A99-01 (FD), A097-A99-02 (LD), A097-A99-03 (SB)	-	.057 pin length
A003-L36-14-TAB	L091-A99-01, L091-A99-02, A090-A99-03	AP01-057	.070, .100, .200, .350 pin length

*Additional body styles and packaging options for GPO thread-in connectors are available.

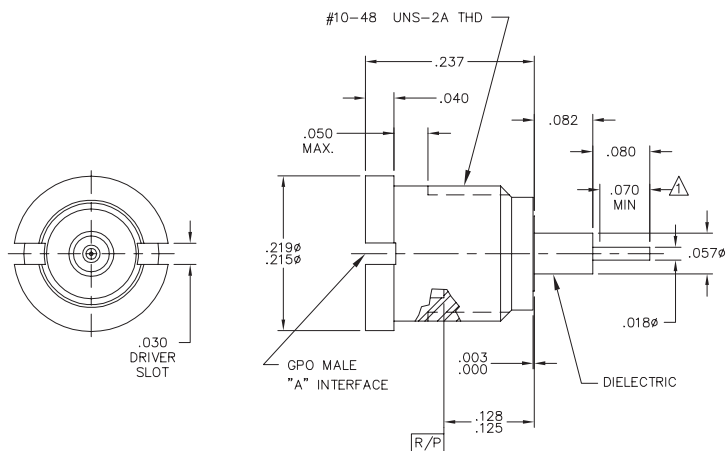

A003-L3X-01



A003-L3X-01

GPO® Thread-In Shrouds

Male Thread-In Shroud (Accepts Pin Subassembly)

Catalog Number	Recommended Tools	Assembly Procedure	Notes
A003-N3X-01	A097-A99-01 (FD), A097-A99-02 (LD), A097-A99-03 (SB), A097-A99-07	AP01-104	Accepts Ø.012 pin subassembly
A003-N3X-02	A097-A99-01 (FD), A097-A99-02 (LD), A097-A99-03 (SB), A097-A99-07	AP01-104	Accepts Ø.012 pin subassembly

*Additional body styles and packaging options for GPO® thread-in connectors are available.

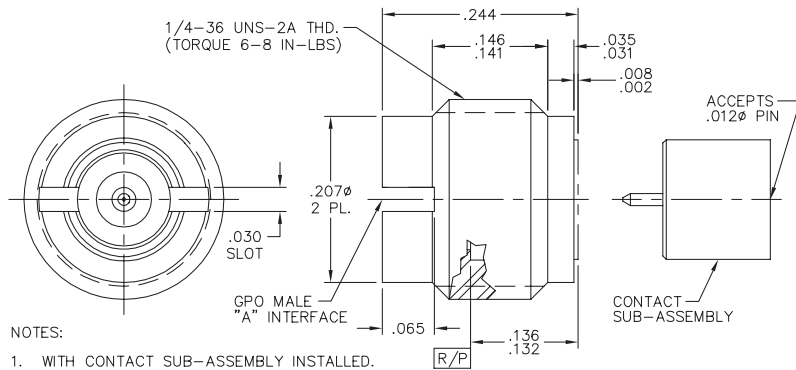

A003-N3X-01



A003-N3X-01

GPO Press-In Shrouds

Male Press-In Shroud

Catalog Number	Recommended Tools	Assembly Procedure	Notes
A005-L3X-01	A090-A99-08	AP01-070	

*Additional body styles and packaging options for GPO press-in connectors are available.

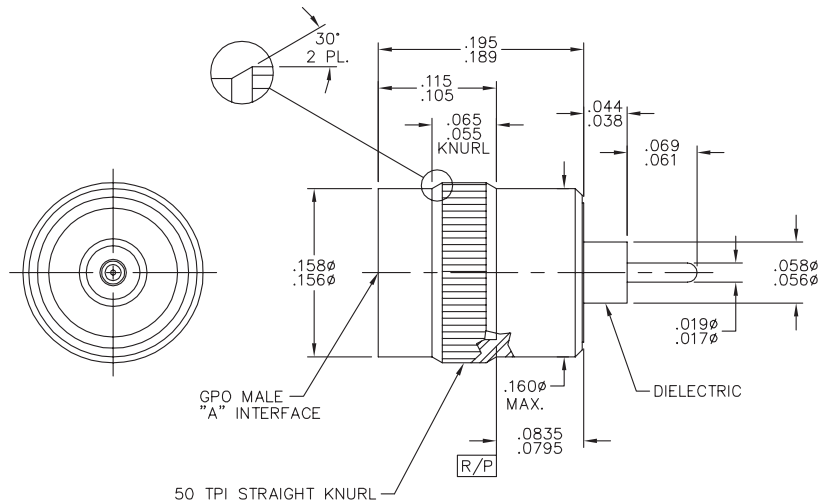

A005-L3X-01



A005-L3X-01

GPO® Solder-On Shrouds

Male Solder-On Shroud with Pin

Catalog Number	Recommended Tools	Assembly Procedure	Notes
A012-T95-01	-	-	Accepts Ø.015 pin (included), alignment plug
A012-T93-02-T	-	-	Accepts Ø.015 pin (included), solder dipped, alignment plug
A012-L9X-04-T	-	-	Accepts Ø.015 pin (included), solder dipped, alignment plug

*Additional body styles and packaging options for GPO® shroud connectors are available.

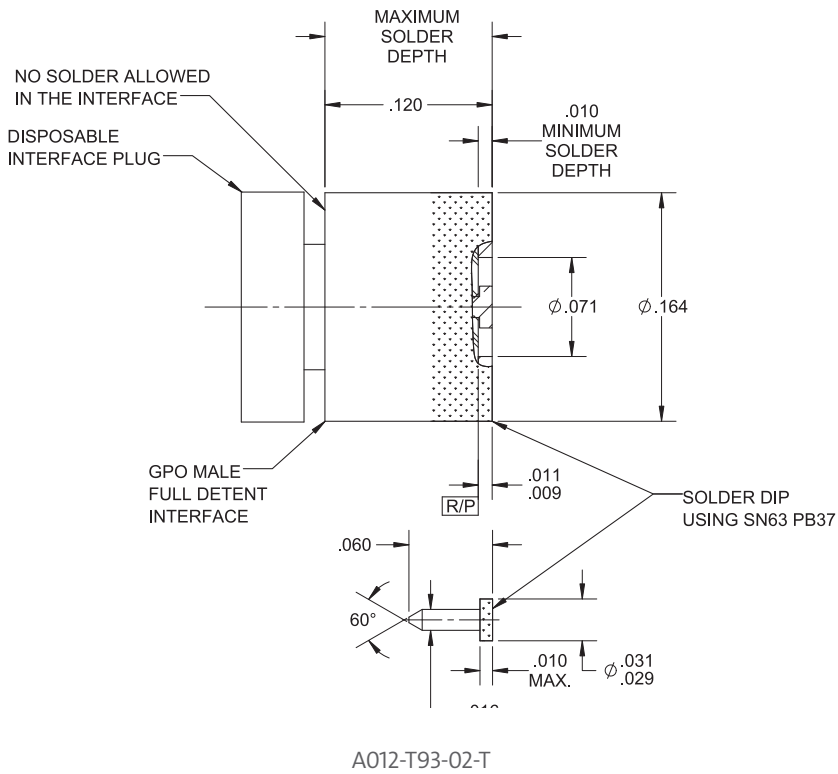

A012-T93-02-T

GPO® Hermetic Shrouds

Male Hermetic Shroud (Full Shroud)

Catalog Number	Recommended Tools	Assembly Procedure	Notes
A007-L4X-01-TAB-R	-	-	Radius pin, pin lengths of .030 to .145-in .005 increments, full body
A007-L4X-01-TAB-S	-	-	Square pin, pin lengths of .030 to .145-in .005 increments, full body
A007-L4X-03-TAB-R	-	-	Radius pin, pin lengths of .030 to .145-in .005 increments, short body
A007-L4X-04-TAB-R	-	-	Radius pin, pin lengths of .030 to .145-in .005 increments, short body
A007-L4X-04-TAB-S	-	-	Square pin, pin lengths of .030 to .145-in .005 increments, short body
A012-T4X-01	-	-	Low-temperature ceramics

*Additional body styles and packaging options for GPO® shroud connectors are available.
 **Full body equals standard interface dimensions and short body equals a compressed/shorter interface.

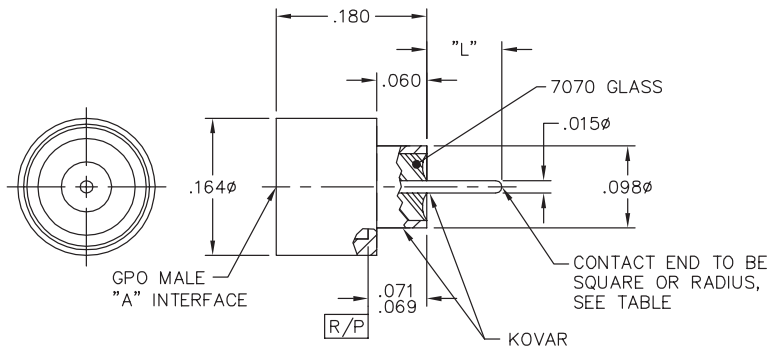

A007-L4X-01-TAB-R

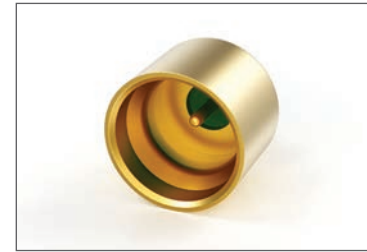

A007-L4X-01-TAB-R

Male Hermetic Shroud (Half Shroud)

Catalog Number	Recommended Tools	Assembly Procedure	Notes
A007-L4X-02-TAB-R	-	-	Radius pin, pin lengths of .030 to .145-in .005 increments, full body
A007-L4X-02-TAB-S	-	-	Square pin, pin lengths of .030 to .145-in .005 increments, full body

*Additional body styles and packaging options for GPO shroud connectors are available.
 **Full body equals standard interface dimensions and short body equals a compressed/shorter interface.

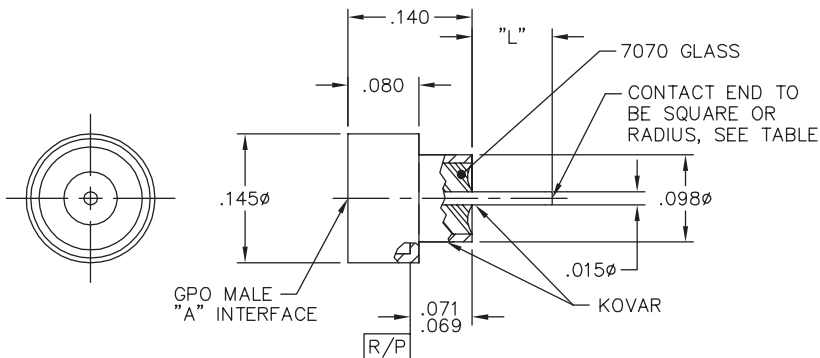

A007-L4X-02-TAB-S



A007-L4X-02-TAB-S

GPO® Hermetic Shrouds

Male Hermetic Shroud

Catalog Number	Recommended Tools	Assembly Procedure	Notes
A007-L4X-31	-	-	
A007-L4X-31-T	-	-	Solder dipped
A007-L4X-09	-	-	
A007-L4X-10-T	-	-	Solder dipped

*Additional body styles and packaging options for GPO® shroud connectors are available.

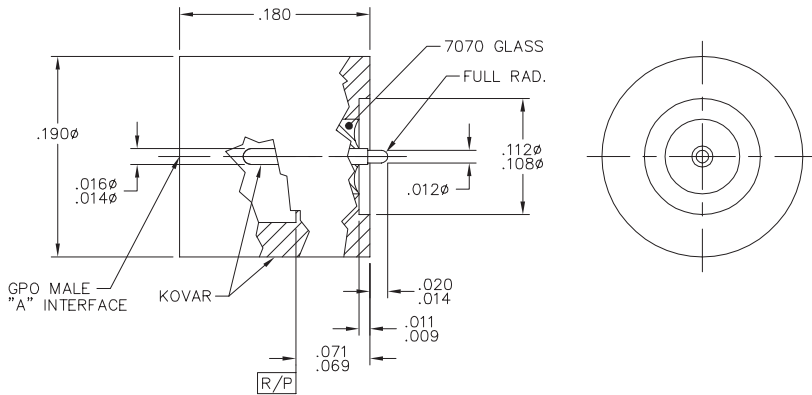

A007-L4X-31

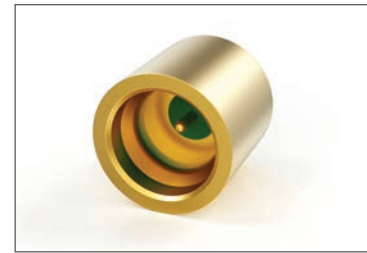

A007-L4X-31

GPO® Flange-Mounts

Male Flange-Mount (Two-Hole, No Center Conductor)

Catalog Number	Recommended Tools	Assembly Procedure	Notes
A001-A2X-03	A090-A99-11, A090-A99-03	AP01-009	Flange diameter \varnothing .480 Flange width .165 Hole spacing .328 Hole size \varnothing .098
A001-A2X-04	A090-A99-10, A090-A99-03	AP01-009	Flange diameter \varnothing .400 Flange width .165 Hole spacing .282 Hole size \varnothing .073
A001-A2X-07	A090-A99-09, A090-A99-03	AP01-009	Flange diameter \varnothing .625 Flange width .165 Hole spacing .481 Hole size \varnothing .103

*Additional body styles and packaging options for GPO® flange-mount connectors are available.

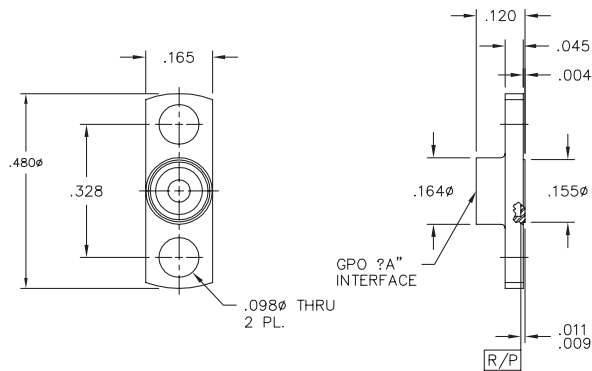

A001-A2X-03



A001-A2X-03

Male Flange-Mount (Four-Hole, No Center Conductor)

Catalog Number	Recommended Tools	Assembly Procedure	Notes
A001-A2X-12	-	-	Flange height .375 square Hole spacing .250 square Hole size \varnothing .073

*Additional body styles and packaging options for GPO flange-mount connectors are available.

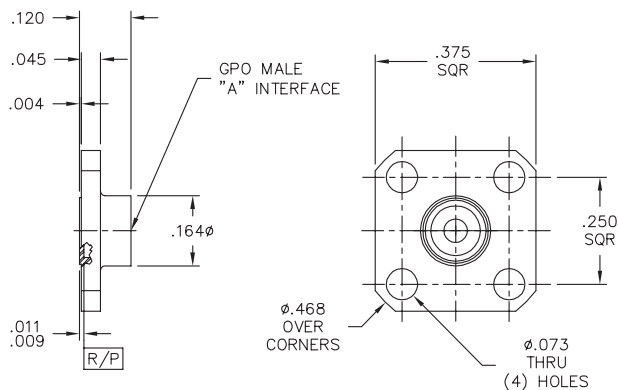

A001-A2X-12

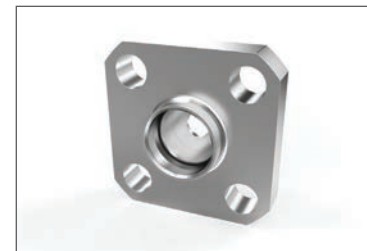

A001-A2X-12

GPO® Flange-Mounts

Male Flange-Mount (Two-Hole, Center Conductor Installed)

Catalog Number	Recommended Tools	Assembly Procedure	Notes
A001-L33-03	-	-	Flange diameter \varnothing .400 Flange width .165 Hole spacing .282 Hole size \varnothing .093 .100 pin length

*Additional body styles and packaging options for GPO® flange-mount connectors are available.

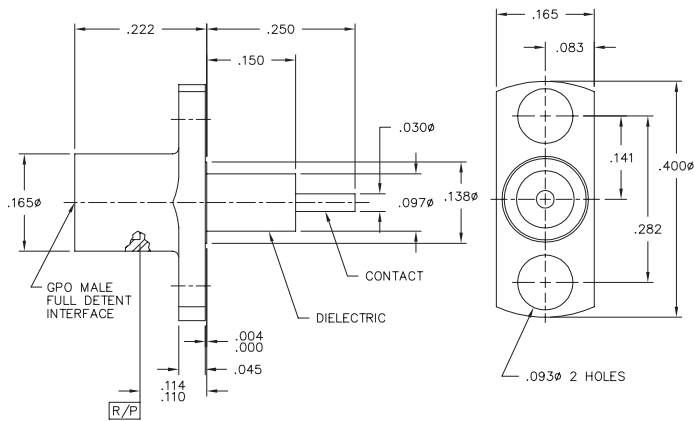

A001-L33-03



A001-L33-03

Male Flange-Mount (Two-Hole, Accepts \varnothing .012 Center Conductor)

Catalog Number	Recommended Tools	Assembly Procedure	Notes
A001-N3X-05	A090-A99-09	-	Flange diameter \varnothing .625 Flange width .165 Hole spacing .481 Hole size \varnothing .103

*Additional body styles and packaging options for GPO flange-mount connectors are available.

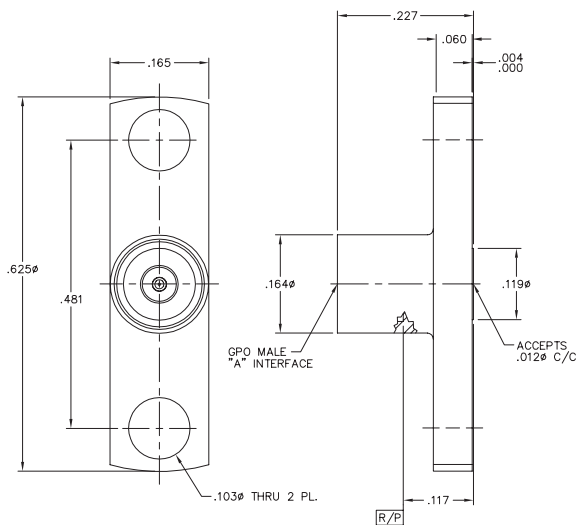

A001-N3X-05



A001-N3X-05

GPO® Flange-Mounts

Male Flange-Mount (Two-Hole, Right-Angle (R/A) Interface)

Catalog Number	Recommended Tools	Assembly Procedure	Notes
A002-N3X-01	-	-	Accepts $\varnothing.015$ center conductor

*Additional body styles and packaging options for GPO® flange-mount connectors are available.

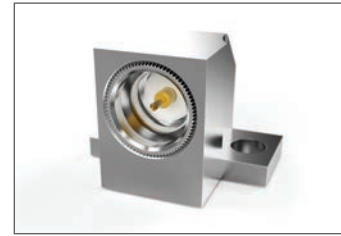
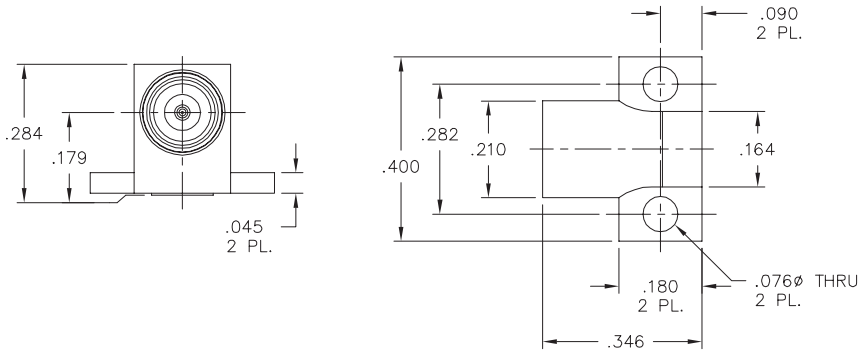

A002-N3X-01

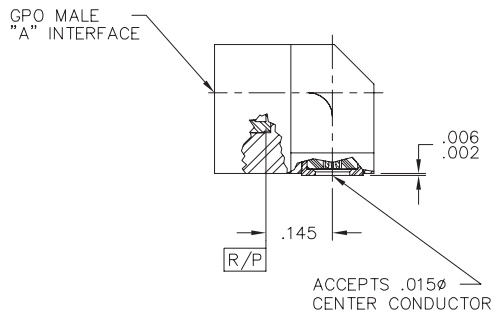

A002-N3X-01

GPO® Multiposition Blocks

Male Four-Position Block

Catalog Number	Recommended Tools	Assembly Procedure	Notes
A036-P95-04	-	-	.175 interface pitch, R/A pin
A036-P95-04-T	-	-	.175 interface pitch, R/A pin, solder dipped

*Additional body styles and packaging options for GPO® multiposition blocks are available.

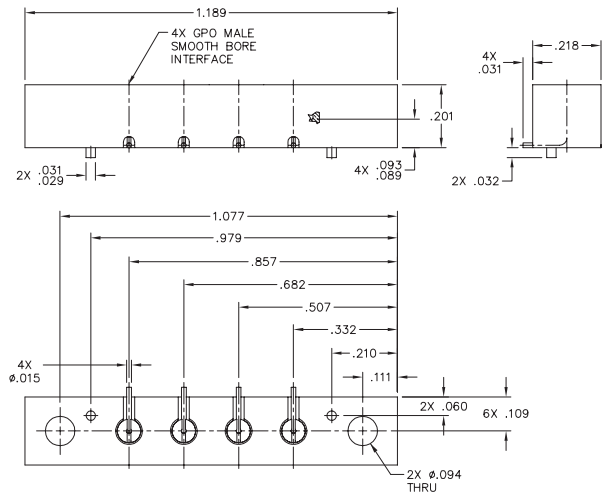

A036-P95-04



A036-P95-04

Male Five-Position Block

Catalog Number	Recommended Tools	Assembly Procedure	Notes
A032-L1X-01-T	-	-	.207 interface pitch, straight pin, solder dipped Plug is for pick and place
A036-T45-01	-	-	.170 interface pitch, straight pin

*Additional body styles and packaging options for GPO multiposition blocks are available.

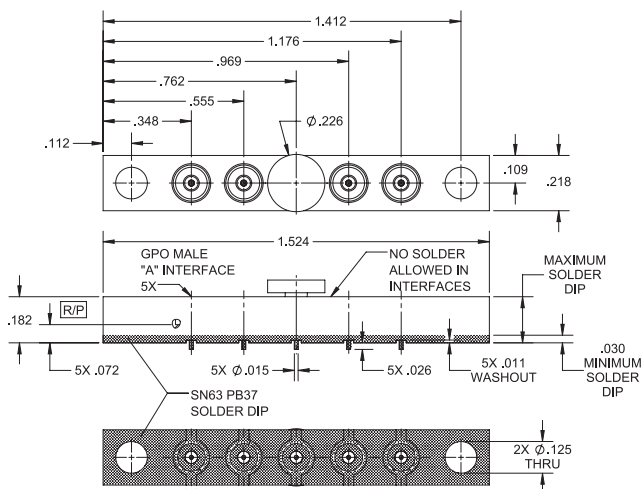

A032-L1X-01-T



A032-L1X-01-T

GPO® Multiposition Blocks

Male Six-Position Block

Catalog Number	Recommended Tools	Assembly Procedure	Notes
A036-P93-02-T	-	-	.250 interface pitch, R/A pin, solder dipped

*Additional body styles and packaging options for GPO® multiposition blocks are available.

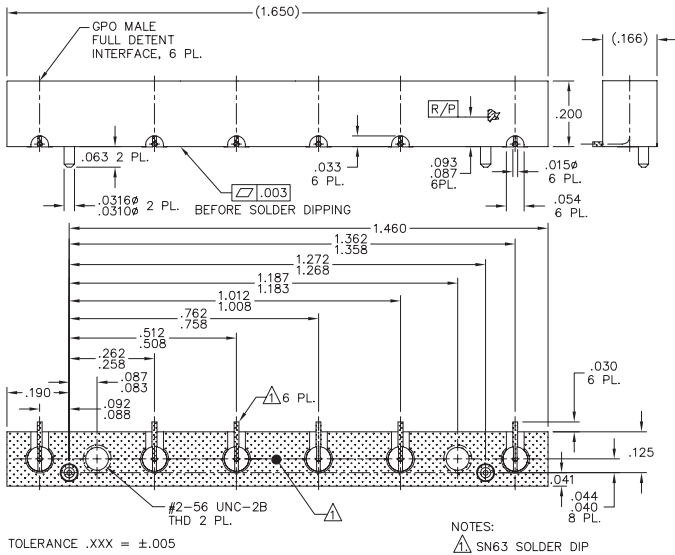

A036-P93-02-T



A036-P93-02-T

Male Seven-Position Block

Catalog Number	Recommended Tools	Assembly Procedure	Notes
A032-L9X-027-T	-	-	.207 interface pitch, straight pin, solder dipped Plug is for pick and place

*Additional body styles and packaging options for GPO multiposition blocks are available.

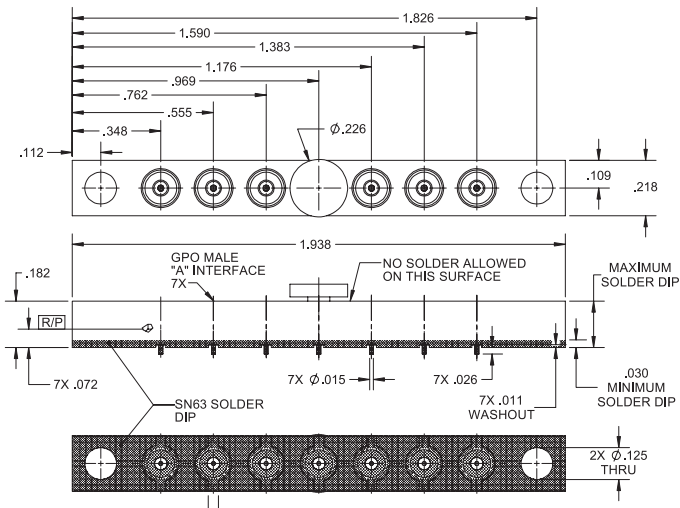

A032-L9X-027-T



A032-L9X-027-T

GPO® Multiposition Blocks

Male Eight-Position Block

Catalog Number	Recommended Tools	Assembly Procedure	Notes
A036-P76-01	-	-	.250 interface pitch, Z-pin
A036-P76-02	-	-	.250 interface pitch, Z-pin
A030-N93-02-T	-	-	.300 interface pitch, R/A pin, solder dipped

*Additional body styles and packaging options for GPO® multiposition blocks are available.

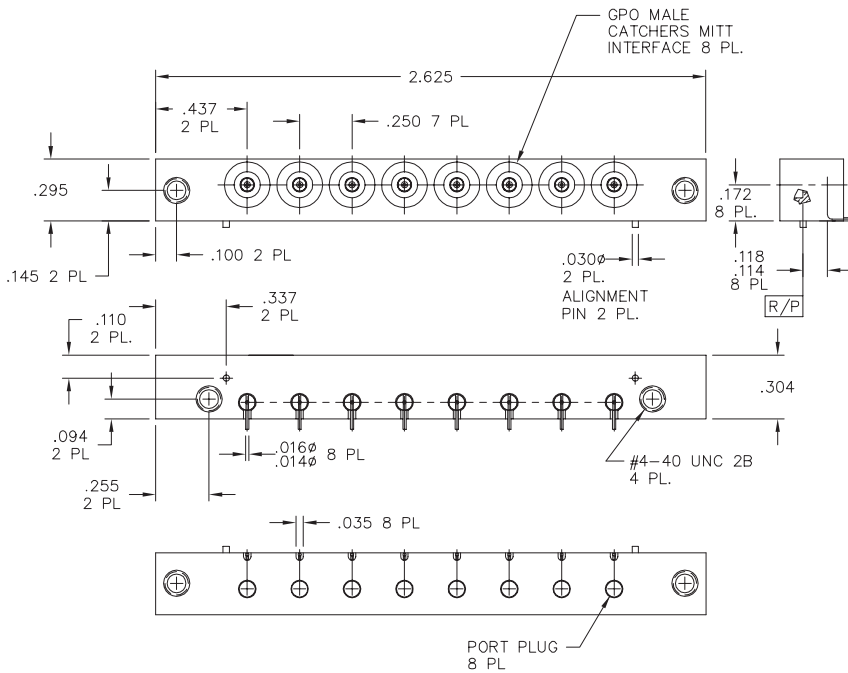

A036-P76-01

A036-P76-01

GPO® Accessories

Female 50 Ohm Load

Catalog Number	Recommended Tools	Assembly Procedure	Notes
A055-A11-01	-	-	Test-grade load
A055-A11-02	-	-	Field-grade load
A055-A11-05	-	-	Snap-in float mount
A055-A11-08	-	-	
A055-A91-02	-	-	Snap-in float mount

*Additional body styles and packaging options for GPO® accessories are available.

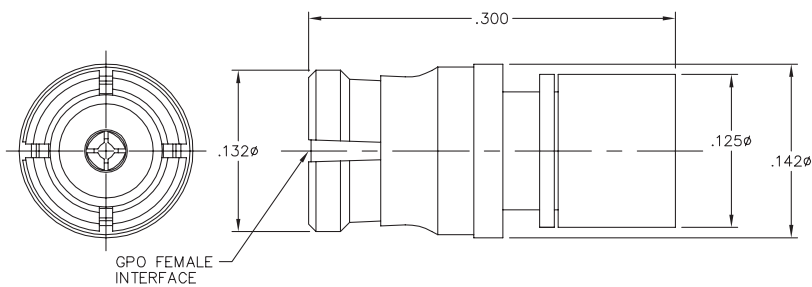

A055-A11-01



A055-A11-01

Male 50 Ohm Load

Catalog Number	Recommended Tools	Assembly Procedure	Notes
A055-A1X-01	-	-	Test-grade load
A055-A1X-02	-	-	Field-grade load

*Additional body styles and packaging options for GPO accessories are available.

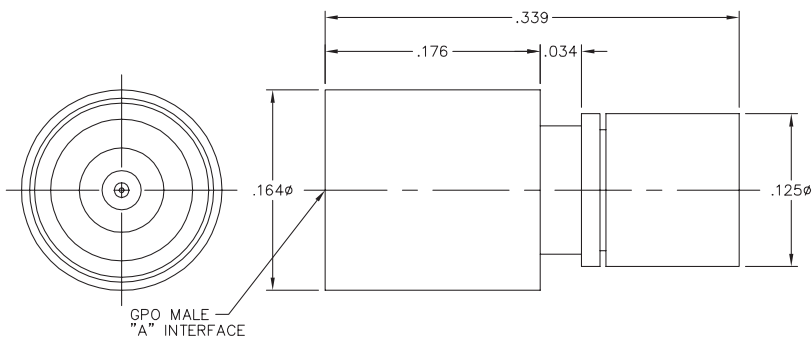

A055-A1X-01



A055-A1X-01

GPO® Accessories

50 Ohm Hermetic Seal

Catalog Number	Recommended Tools	Assembly Procedure	Notes
Y007-L42-02	-	-	.125 pin length
Y007-L42-03	-	-	.050 pin length
Y007-L42-04	-	-	.200 pin length

*Additional body styles and packaging options for GPO® accessories are available.

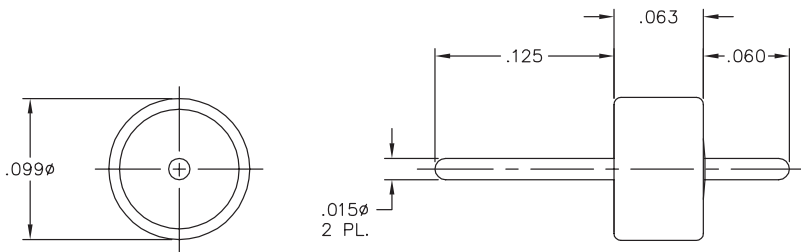

Y007-L42-02



Y007-L42-02

Interface Plug (Alignment Plug)

Catalog Number	Recommended Tools	Assembly Procedure	Notes
Y072-A0X-07	-	-	

*Additional body styles and packaging options for GPO accessories are available.

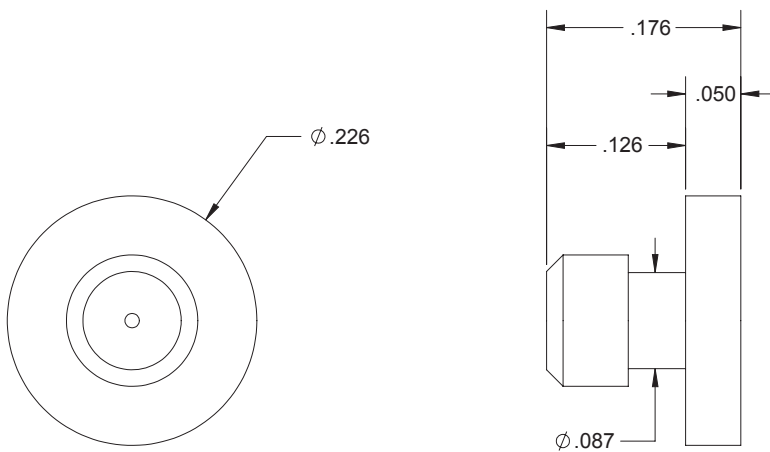

Y072-A0X-07



Y072-A0X-07

GPO® Accessories

EMI Shield Ring

Catalog Number	Recommended Tools	Assembly Procedure	Notes
Y099-A99-13	-	-	Gasket may reduce radial misalignment tolerance of the interconnect

*Additional body styles and packaging options for GPO® accessories are available.

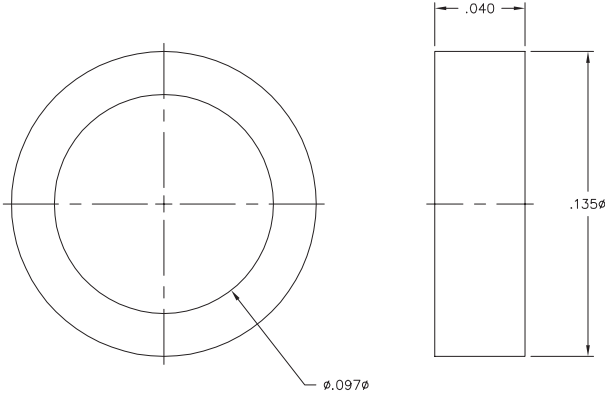

Y099-A99-13



Y099-A99-13



GPPO® Products

- Center-to-center spacing of 0.140-in available for increased package density
- Frequency from DC to 65 GHz
- Designed to accommodate both radial and axial misalignment with negligible voltage standing wave ratio (VSWR) change
- Adapters available to sub-miniature, part A (SMA), 2.4 mm, and 1.85 mm



GPPO® Specifications

General Characteristics

Impedance	50 Ohms nominal
Frequency range	DC to 65 GHz
Temperature range	-65°C to 165°C

Electrical Characteristics

VSWR	1.10: 1 to 26.5 GHz typical; 130: 1 typical to 50 GHz
Insertion loss	.04 √f (GHz)
DWV @ sea level	325 V _{rms}
Insulation resistance	5,000 megohms minimum
Contact resistance	
Outer conductor	2 milliohms maximum
Inner conductor	6 milliohms maximum
RF leakage	-80 dB (typical mated pair)

Mechanical Characteristics

Mate/demate cycles	Full detent (FD) - 100 minimum; smooth bore - 500 minimum
Force to engage/disengage	FD - 4.5 lbs typical/6.5 lbs typical; SB - 2.5 lbs typical/1.5 lbs typical
Tolerated misalignment	
Radial	+/-0.010
Axial	0.010 (flush to 0.010 from the reference plane)

Environmental Characteristics

Thermal shock	MIL-STD-202, Method 107, Condition B
Salt spray	MIL-STD-202, Method 101
Vibration	MIL-STD-202, Method 204
Shock	MIL-STD-202, Method 213, Condition I
Moisture resistance	MIL-STD-202, Method 106, except Step 7B

Materials (typical)

Bodies	Beryllium copper per ASTM B196 and or/ASTM B197
Outer contacts	Beryllium copper per ASTM B196 and or/ASTM B197
Center contacts	Beryllium copper per ASTM B196 and or/ASTM B197
Insulators	PTFE fluorocarbon per ASTM D1710
Springs	17-7 Stainless Steel per ASTM A313-95A

Finish (typical)

Bodies	Gold plated per MIL-G-45204, Type I, Grade C, Class 1, over nickel plate per SAE AMS-QQ-N-290
Contacts	Gold plated per MIL-G-45204, Type I, Grade C, Class 1, over nickel plate per SAE AMS-QQ-N-290

GPPO® Blind Mate Interconnects

Female Blind Mate Interconnect (Bullet) Connector – Standard

Catalog Number	Length (inches)	Recommended Tools	Assembly Procedure	Notes
B1B1-0001-05	.166	B095-A99-01	-	
B1B1-0001-25	.596	B095-A99-01	-	
B1B1-0001-26	1.310	B095-A99-01	-	

*Additional lengths available upon request.

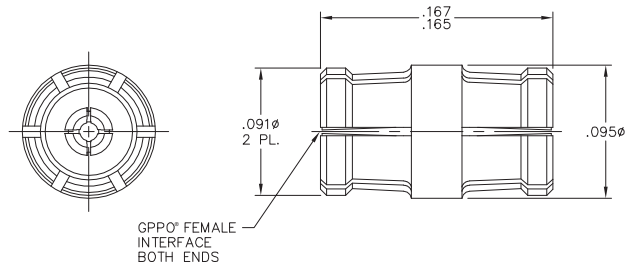

B1B1-0001-05



B1B1-0001-05



B1B1-0001-26

Female Blind Mate Interconnect (Bullet) Connector – Alignment Features

Catalog Number	Length (inches)	Recommended Tools	Assembly Procedure	Notes
B1B1-0009-04-0500	.500	B095-A99-01	-	Silicon o-ring
B1B1-0009-05-0500	.500	B095-A99-01	-	Acetal o-ring

*O-rings and gaskets are for alignment only and are not to be used for shielding applications.

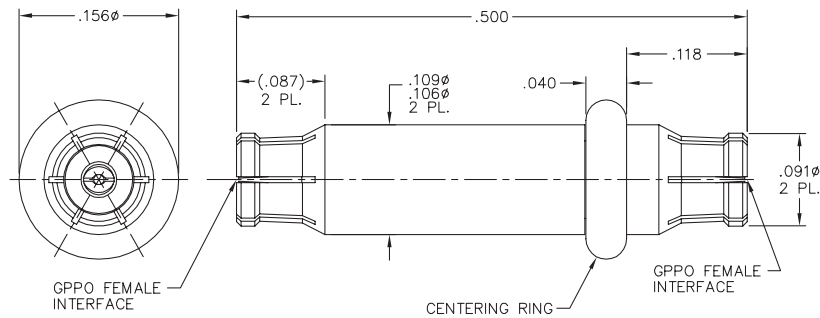

B1B1-0009-04-0500



B1B1-0009-04-0500

GPPO® Blind Mate Interconnects

Female Blind Mate Interconnect (Bullet) Connector – Spring Loaded/Self-Adjusting

Catalog Number	Relaxed Length (inches)	Compressed Length (inches)	Recommended Tools	Assembly Procedure	Notes
B1B1-0001-10	.412	.382	B095-A99-01	-	
B1B1-0001-38	.412	.382	B095-A99-01	-	Larger outer diameter than B1B1-0001-10
B1B1-0001-39	.424	.394	B095-A99-01	-	
B1B1-0001-37	.552	.502	B095-A99-01	-	
B1B1-0001-11	.646	.591	B095-A99-01	-	

*O-rings and gaskets are for alignment only and are not to be used for shielding applications.

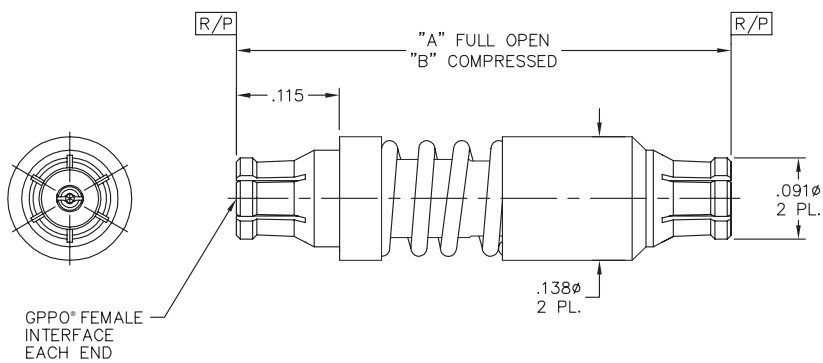

B1B1-0001-37



B1B1-0001-37

GPPO® to .047 Cable Connectors

Female Straight to .047 Semi-Rigid (S/R) Cable

Catalog Number	Recommended Tools	Assembly Procedure	Notes
B014-B11-01	B096-A93-01, A096-A99-04, L096-A99-02, B098-A99-03	AP01-133	

*Semi-flex cable can be substituted in place of .047 semi-rigid.
 **Additional cable options for GPPO® female straight connectors are available.

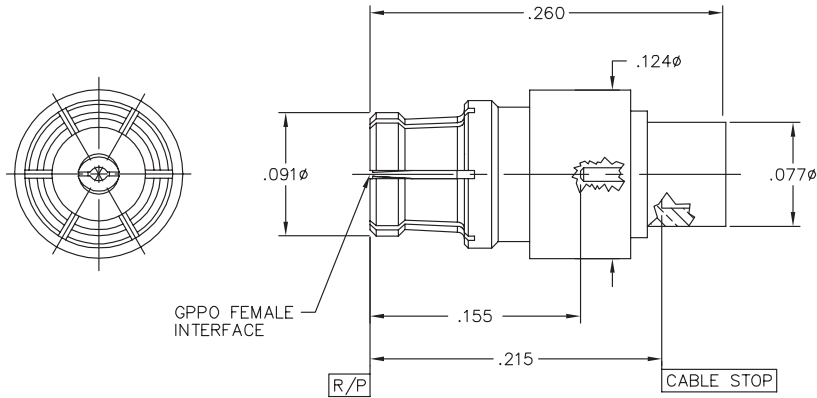

B014-B11-01



B014-B11-01

Female Right-Angle (R/A) to .047 Semi-Rigid (S/R) Cable

Catalog Number	Recommended Tools	Assembly Procedure	Notes
B015-B11-01	B096-A93-01, A096-A99-09, L096-A99-02, B098-A99-07	AP01-080	
B015-B11-02	B096-A93-01, A096-A99-10, L096-A99-02, B098-A99-07	AP01-076	Swept contact
B015-B11-04	B096-A93-01, A096-A99-09, L096-A99-02, B098-A99-07	AP01-150	

*Semi-flex cable can be substituted in place of .047 semi-rigid.
 **Additional cable options for GPPO female right-angle connectors are available.

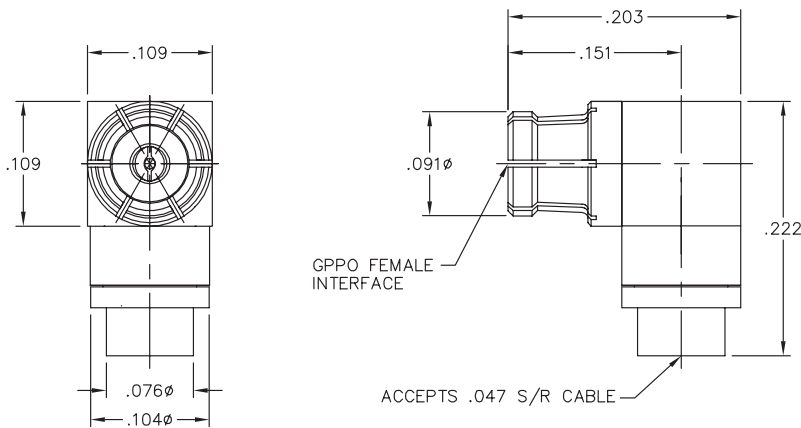

B015-B11-02



B015-B11-02

GPPO® to .047 Cable Connectors

Male Right-Angle (R/A) to .047 Semi-Rigid (S/R) Cable

Catalog Number	Recommended Tools	Assembly Procedure	Notes
B019-B36-02	9001-823-0	AP01-156	Float mount

*Semi-flex cable can be substituted in place of .086 semi-rigid.
 **Additional cable options for GPPO® male right-angle connectors are available.

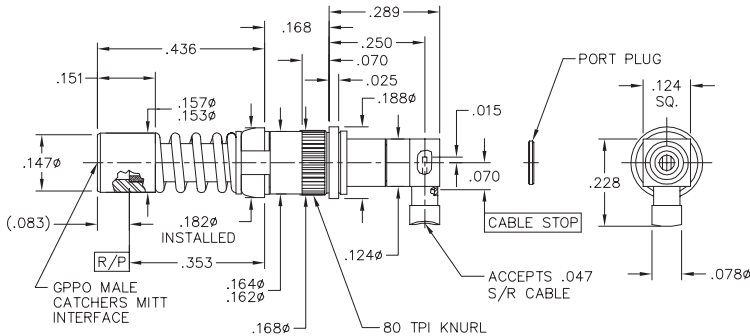

B019-B36-02



B019-B36-02

Male Bulkhead to .047 Semi-Rigid (S/R) Cable

Catalog Number	Recommended Tools	Assembly Procedure	Notes
B016-B3X-02	B096-A99-01 (FD), B096-A99-02 (SB), L096-A99-02, B097-A99-01	AP01-110	

*Semi-flex cable can be substituted in place of .047 semi-rigid.
 **Additional cable options for GPPO male bulkhead connectors are available.

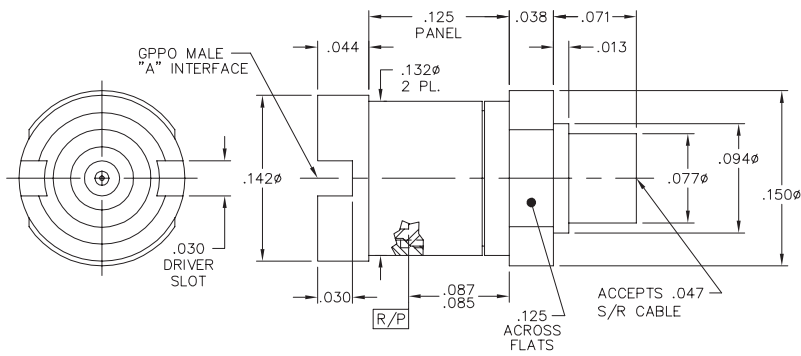

B016-B3X-02



B016-B3X-02

GPPO® to .047 Cable Connectors

Female Snap-In to .047 Semi-Rigid (S/R) Cable

Catalog Number	Recommended Tools	Assembly Procedure	Notes
B016-B11-01	B096-A93-01, A096-A99-09, L096-A99-02, 9001-824-0	AP01-103	

*Semi-flex cable can be substituted in place of .047 semi-rigid.
 **Additional cable options for GPPO® female snap-in connectors are available.

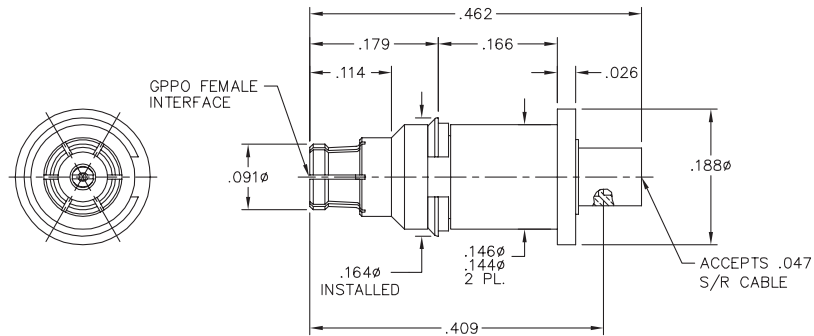

B016-B11-01



B016-B11-01

Male Snap-In to .047 Semi-Rigid (S/R) Cable

Catalog Number	Recommended Tools	Assembly Procedure	Notes
B016-B3X-01	B096-A99-01 (FD), B096-A99-02 (SB), L096-A99-02, B098-A99-05	AP01-094	

*Semi-flex cable can be substituted in place of .047 semi-rigid.
 **Additional cable options for GPPO male snap-in connectors are available.

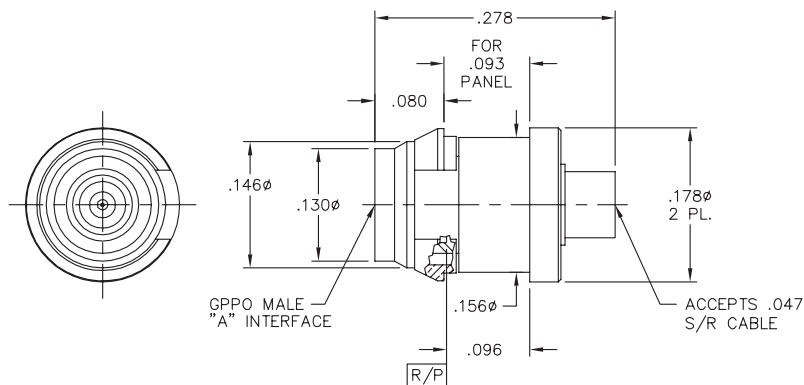

B016-B3X-01



B016-B3X-01

GPPO® to .086 Cable Connectors

Female Straight to .086 Semi-Rigid (S/R) Cable

Catalog Number	Recommended Tools	Assembly Procedure	Notes
B014-D11-01	B096-A93-01, A096-A99-04, L096-A99-01, B098-A99-03	AP01-148	

*Semi-flex cable can be substituted in place of .086 semi-rigid.
 **Additional cable options for GPPO® female straight connectors are available.

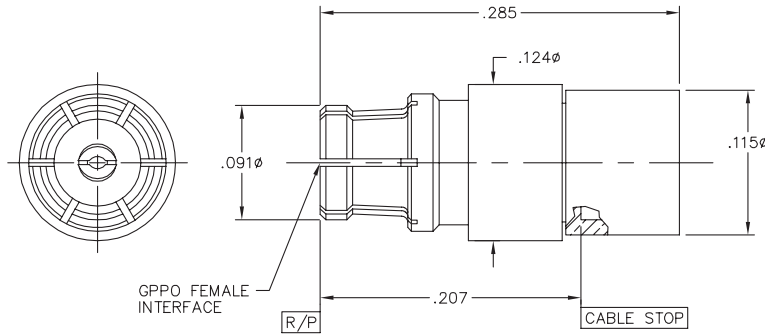

B014-D11-01



B014-D11-01

Female Right-Angle (R/A) to .086 Semi-Rigid (S/R) Cable

Catalog Number	Recommended Tools	Assembly Procedure	Notes
B015-D11-01	B096-A93-01, A096-A99-10, L096-A99-01, B098-A99-07	AP01-112	Swept contact
B015-D11-02	B096-A93-01, A096-A99-10, L096-A99-01, B098-A99-07	-	
B015-D11-05	B096-A93-01, A096-A99-10, L096-A99-01, B098-A99-07	-	

*Semi-flex cable can be substituted in place of .086 semi-rigid.
 **Additional cable options for GPPO female right-angle connectors are available.

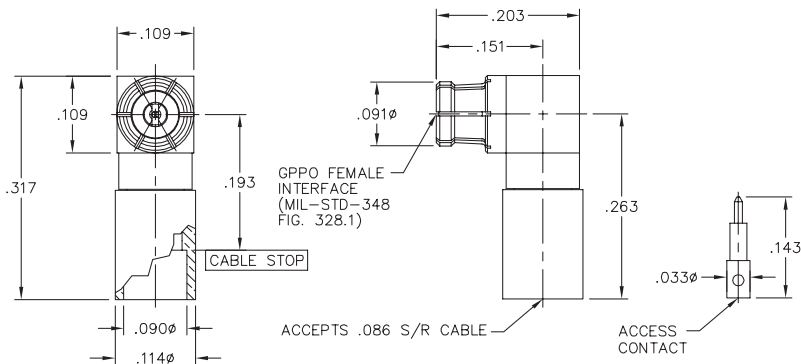

B015-D11-01



B015-D11-01

GPPO® to .086 Cable Connectors

Male Right-Angle (R/A) to .086 Semi-Rigid (S/R) Cable

Catalog Number	Recommended Tools	Assembly Procedure	Notes
B019-D36-01	9001-823-0	AP01-145	Float mount

*Semi-flex cable can be substituted in place of .086 semi-rigid.
 **Additional cable options for GPPO® male right-angle connectors are available.

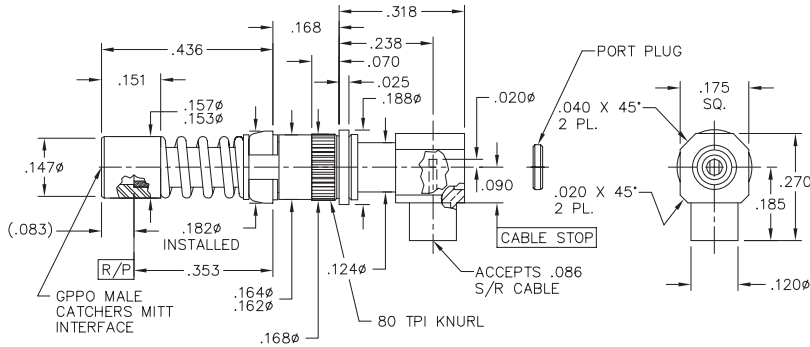

B019-D36-01



B019-D36-01

Male Flange-Mount to .086 Semi-Rigid (S/R) Cable

Catalog Number	Recommended Tools	Assembly Procedure	Notes
B001-D3X-01	B096-A99-01 (FD), B096-A99-02 (SB), L096-A99-01	AP01-119	

*Semi-flex cable can be substituted in place of .086 semi-rigid.
 **Additional cable options for GPPO male flange connectors are available.

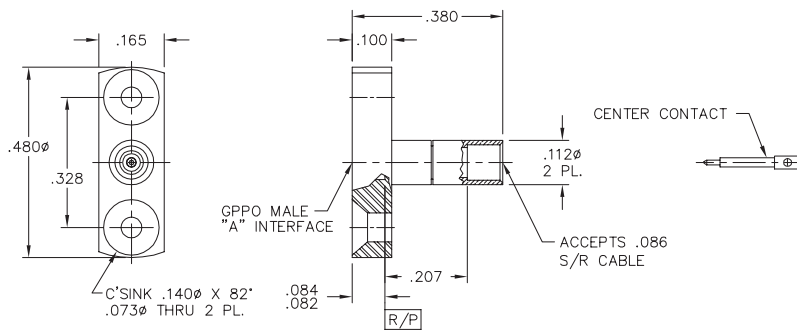

B001-D3X-01



B001-D3X-01

GPPO® to .086 Cable Connectors

Male Bulkhead to .086 Semi-Rigid (S/R) Cable

Catalog Number	Recommended Tools	Assembly Procedure	Notes
B016-D3X-02	B096-A99-01 (FD), B096-A99-02 (SB), L096-A99-01, B097-A99-01	AP01-111	
B014-D3X-07	B096-A99-01 (FD), B096-A99-02 (SB), L096-A99-01, B097-A99-01	AP01-111	

*Semi-flex cable can be substituted in place of .086 semi-rigid.
 **Additional cable options for GPPO® male bulkhead connectors are available.

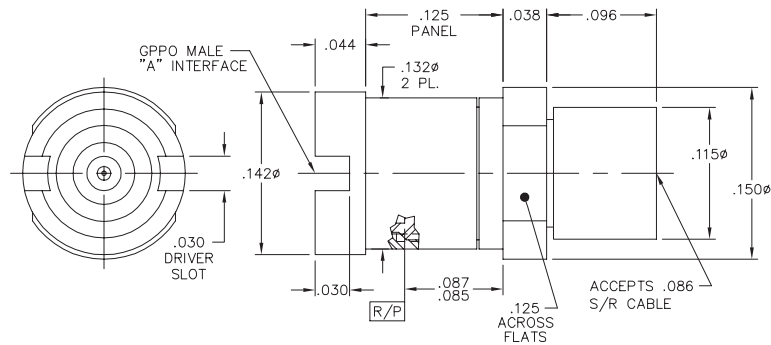

B016-D3X-02



B016-D3X-02

Female Snap-In to .086 Semi-Rigid (S/R) Cable

Catalog Number	Recommended Tools	Assembly Procedure	Notes
B014-D11-04	B096-A93-01, A096-A99-09, L096-A99-01, 9001-824-0	-	

*Semi-flex cable can be substituted in place of .086 semi-rigid.
 **Additional cable options for GPPO female snap-in connectors are available.

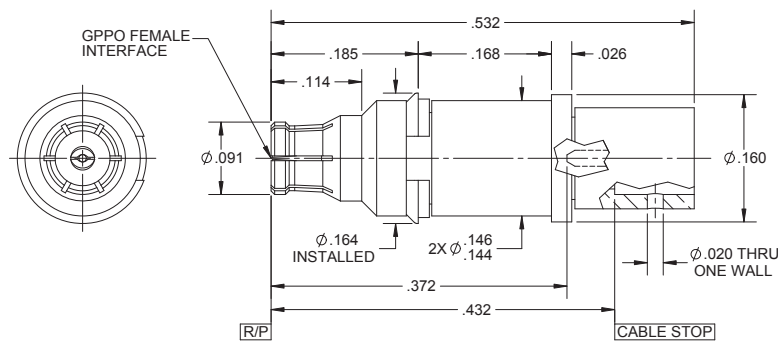

B014-D11-04



B014-D11-04

GPPO® to .086 Cable Connectors

Male Snap-In to .086 Semi-Rigid (S/R) Cable

Catalog Number	Recommended Tools	Assembly Procedure	Notes
B016-D3X-01	B096-A99-01, L096-A99-01, B098-A99-05	AP01-092	
B018-D96-01	B096-A99-02, L096-A99-01, B098-A99-05	AP01-090	Float mount

*Semi-flex cable can be substituted in place of .086 semi-rigid.

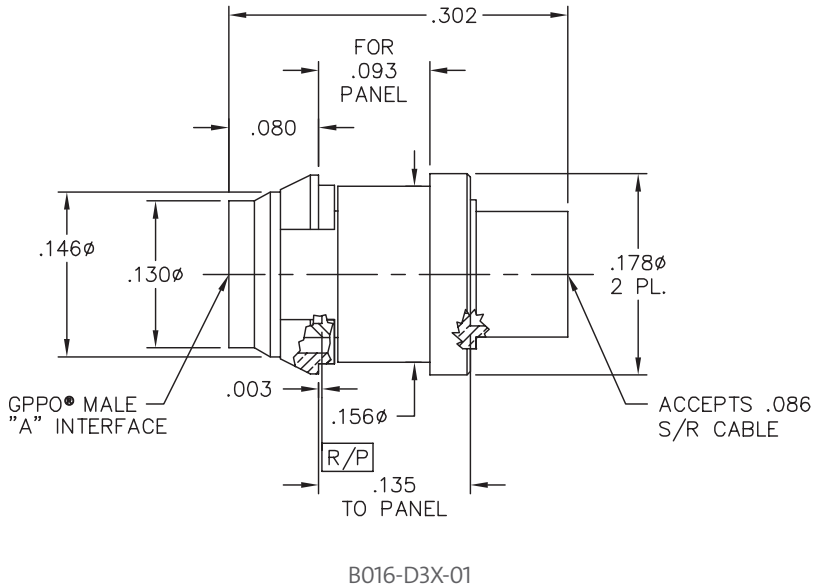

B016-D3X-01

GPPO® Vertical Launch PCB Mounts

Male Straight to PCB, Square Body

Catalog Number	Recommended Tools	Assembly Procedure	Notes
B008-L1X-01	-	-	.096 leg length
B008-L1X-01@T13	-	-	.096 leg length, on tape and reel
B008-L1X-01-T	-	-	.096 leg length, solder dipped
B008-L1X-01-T@T13	-	-	.096 leg length, solder dipped, on tape and reel
B008-L1X-07-T	-	-	.140 leg length, solder dipped
B008-L1X-03	-	-	.200 leg length
B008-L1X-03-T	-	-	.200 leg length, solder dipped

*Additional leg length, body styles, and packaging options for GPPO® male straight to PCB connectors are available.

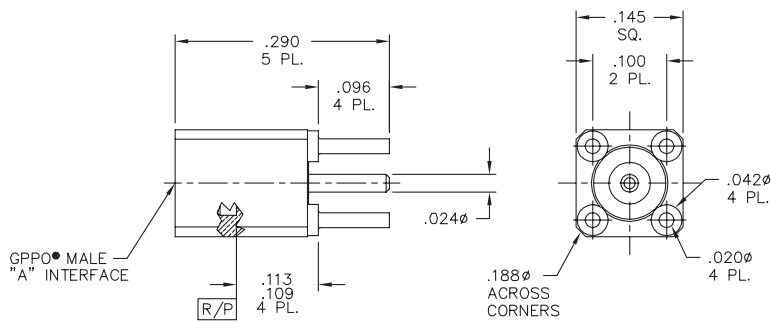

B008-L1X-01

B008-L1X-01

Male Straight to PCB, Round Body

Catalog Number	Recommended Tools	Assembly Procedure	Notes
B008-L3X-01-TAB	-	-	.055, .100 leg length

*Additional leg length, body styles, and packaging options for GPPO male straight to PCB connectors are available.

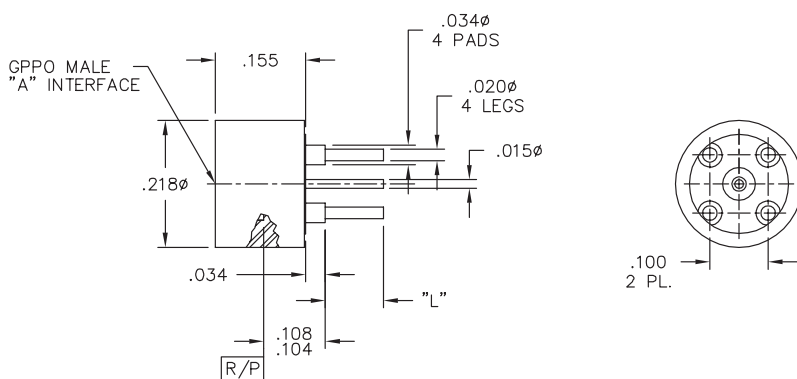

B008-L3X-01-TAB

B008-L3X-01-TAB

GPPO® Vertical Launch PCB Mounts

Male Straight to PCB, Separate Center Conductor (C/C)

Catalog Number	Recommended Tools	Assembly Procedure	Notes
B012-L1X-01	B096-A99-01 (FD), B096-A99-02 (SB)	-	.093 pin length
B012-L1X-01-T	B096-A99-01 (FD), B096-A99-02 (SB)	-	.093 pin length, solder dipped
B012-L1X-02	B096-A99-01 (FD), B096-A99-02 (SB)	-	.005 pin length
B012-L1X-04	B096-A99-01 (FD), B096-A99-02 (SB)	-	.093 pin length
B012-L1X-09-T	-	-	.090 pin length, solder dipped, interface plug
B012-L1X-09-T@T13	-	-	.090 pin length, solder dipped, interface plug, on tape and reel
B012-L1X-16-T	-	-	.009 pin length, solder dipped, interface plug

*Additional leg length, body styles, and packaging options for GPPO® male straight to PCB connectors are available.

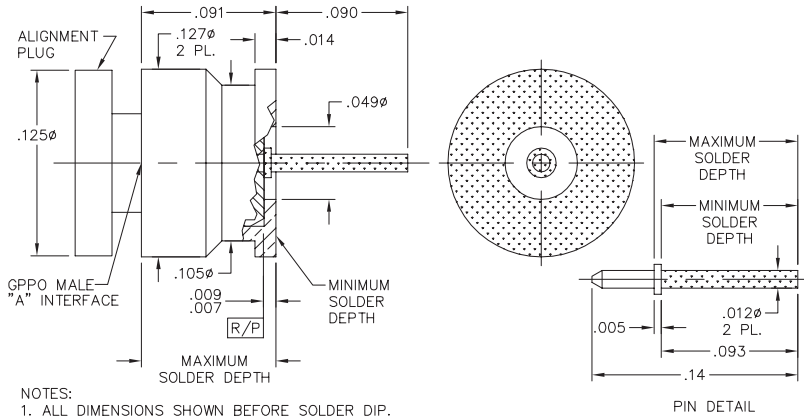

B012-L1X-09-T



B012-L1X-09-T

GPPO® Vertical Launch PCB Mounts

Male Straight to PCB, Right-Angle (R/A) Center Conductor (C/C)

Catalog Number	Recommended Tools	Assembly Procedure	Notes
B012-P9X-01	B096-A99-01 (FD), B096-A99-02 (SB)	-	No legs
B012-P9X-01@T13	B096-A99-01 (FD), B096-A99-02 (SB)	-	No legs, on tape and reel
B012-P9X-01-T	B096-A99-01 (FD), B096-A99-02 (SB)	-	No legs, solder dipped
B012-P9X-01-T@T13	B096-A99-01 (FD), B096-A99-02 (SB)	-	No legs, solder dipped, on tape and reel
B012-P9X-02	-	-	.075 leg length, interface plug
B012-P9X-02@T13	-	-	.075 leg length, interface plug, on tape and reel
B012-P9X-02-T	-	-	.075 leg length, solder dipped, interface plug
B012-P9X-02-T@T13	-	-	.075 leg length, solder dipped, interface plug, on tape and reel
B012-P9X-04	-	-	.125 leg length, interface plug
B012-P9X-04-T	-	-	.125 leg length, solder dipped, interface plug
B012-P9X-04-T@T13	-	-	.125 leg length, solder dipped, interface plug, on tape and reel
B012-P9X-08	B096-A99-01 (FD), B096-A99-02 (SB)	-	.100 leg length
B012-P9X-09	-	-	.075 leg length, interface plug
B012-P9X-10-T	B096-A99-01 (FD), B096-A99-02 (SB)	-	No legs, solder dipped
B012-P9X-10-T@T13	B096-A99-01 (FD), B096-A99-02 (SB)	-	No legs, solder dipped, on tape and reel
B012-P9X-11-T	-	-	.075 leg length, solder dipped, interface plug
B012-P9X-11-T@T13	-	-	.075 leg length, solder dipped, interface plug, on tape and reel
B012-P9X-13	-	-	No legs, interface plug
B012-P9X-14-T	B096-A99-01 (FD), B096-A99-02 (SB)	-	No legs, solder dipped
B012-P9X-16	-	-	.100 leg length, solder dipped, interface plug

*Additional leg length, body styles, and packaging options for GPPO® male straight to PCB connectors are available.

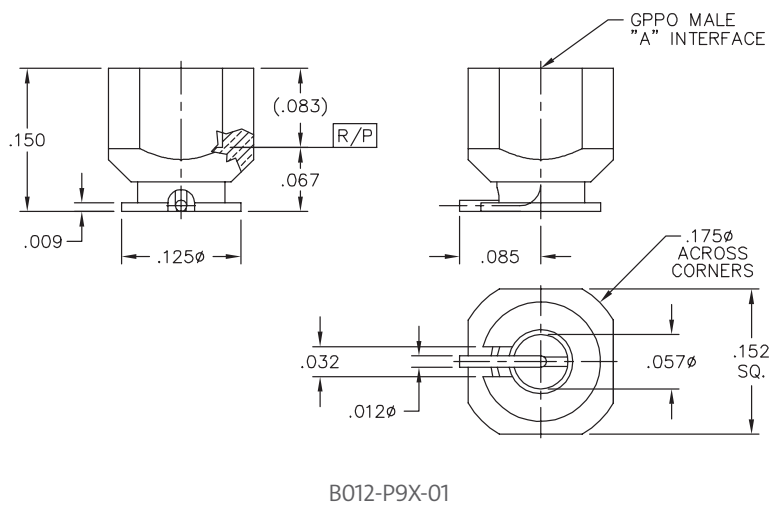

B012-P9X-01

GPPO® Vertical Launch PCB Mounts

Male Straight to PCB, Separate Right-Angle (R/A) Center Conductor (C/C)

Catalog Number	Recommended Tools	Assembly Procedure	Notes
B008-P3X-01	B096-A99-01 (FD), B096-A99-02 (SB)	-	.100 leg length
B008-P3X-04-TAB	B096-A99-01 (FD), B096-A99-02 (SB)	-	.055, .100 leg length

*Additional leg length, body styles, and packaging options for GPPO® male straight to PCB connectors are available.

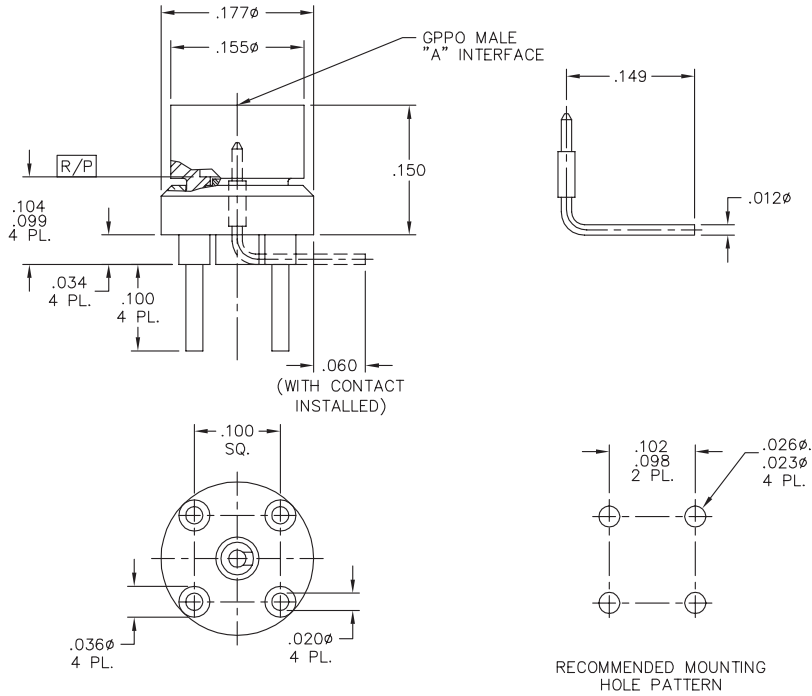

B008-P3X-01

B008-P3X-01

GPPO® Right-Angle PCB Mounts

Male Right Angle to PCB

Catalog Number	Recommended Tools	Assembly Procedure	Notes
B009-P3X-01	-	-	.096 leg length
B009-P3X-01-T	-	-	.096 leg length
B009-P3X-01-T@T13	-	-	.096 leg length, on tape and reel
B009-P3X-02	-	-	.135 leg length
B009-P3X-02-T	-	-	.135 leg length
B009-P3X-02-T@T13	-	-	.135 leg length, on tape and reel
B009-P3X-03	-	-	.072 leg length
B009-P3X-05	-	-	.085 leg length
B009-P3X-09	-	-	.185 leg length

*Additional leg length, body styles, and packaging options for GPPO® male right-angle to PCB connectors are available.

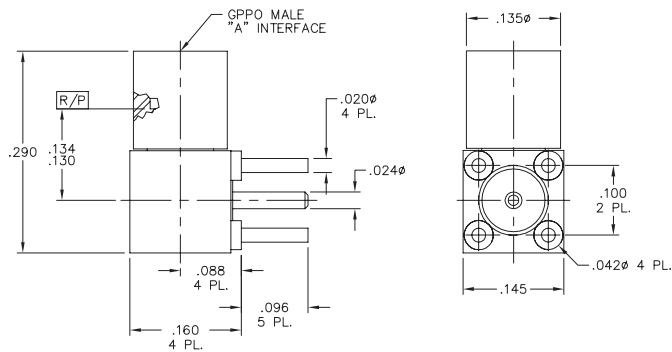

B009-P3X-01



B009-P3X-01

Male Right-Angle Z-Pin to PCB

Catalog Number	Recommended Tools	Assembly Procedure	Notes
B013-L9X-01	-	-	
B013-L9X-01-T	-	-	Solder dipped

*Additional leg length, body styles, and packaging options for GPPO male right-angle to PCB connectors are available.

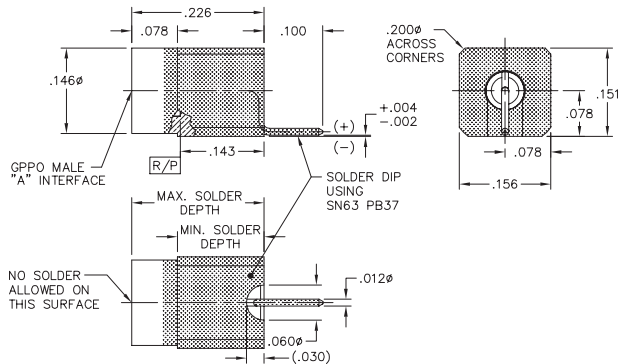

B013-L9X-01



B013-L9X-01

GPPO® Edge Mounts

Male Edge Flush Mount

Catalog Number	Recommended Tools	Assembly Procedure	Notes
B010-L1X-01	-	-	
B010-L1X-01-T	-	-	Solder dipped
B010-L1X-01-T@T13	-	-	Solder dipped, on tape and reel
B010-L1X-04-T	-	-	Solder dipped, interface plug

*Additional body styles and packaging options for GPPO® male edge-mount to PCB connectors are available.

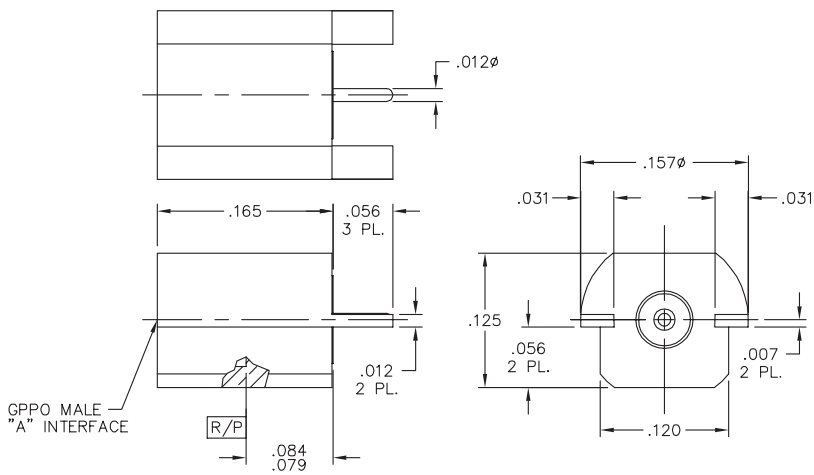

B010-L1X-01



B010-L1X-01

Male Edge Mount

Catalog Number	Recommended Tools	Assembly Procedure	Notes
B010-L8X-02	-	-	
B010-L8X-02-T	-	-	Solder dipped

*Additional body styles and packaging options for GPPO male edge-mount to PCB connectors are available.

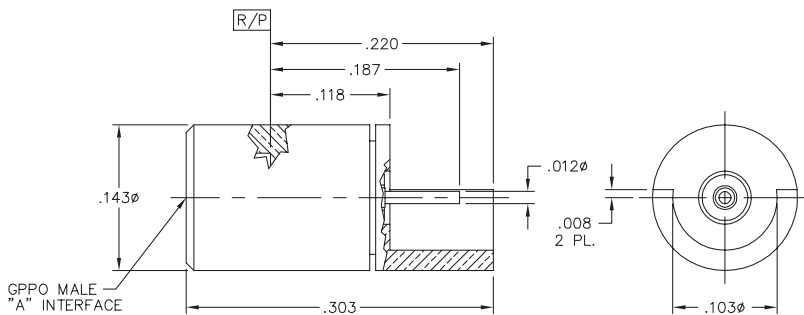

B010-L8X-02



B010-L8X-02

GPPO® Thread-In Shrouds

Male Thread-In Shroud (No Pin)

Catalog Number	Recommended Tools	Assembly Procedure	Notes
B003-A2X-01	B097-A99-01 (FD), B097-A99-02 (SB), B099-A99-01, B099-A99-02, B090-A99-05	AP01-101	

*Additional body styles and packaging options for GPPO® thread-in connectors are available.

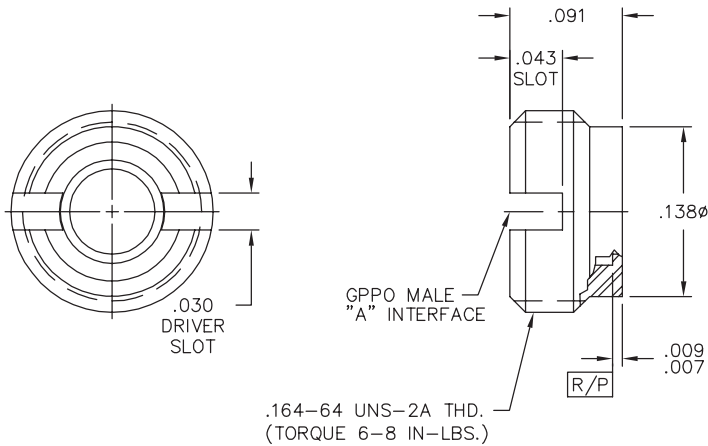

B003-A2X-01



B003-A2X-01

Male Thread-In Shroud (With Pin)

Catalog Number	Recommended Tools	Assembly Procedure	Notes
B003-L3X-01	B097-A99-01 (FD), B097-A99-02 (SB), B099-A99-01, B099-A99-02, B090-A99-05	-	.015 pin length
B003-L3X-02	B097-A99-01 (FD), B097-A99-02 (SB), B099-A99-01, B099-A99-02, B090-A99-05	-	.065 pin length
B003-L3X-05	B097-A99-01 (FD), B097-A99-02 (SB), B099-A99-01, B099-A99-02, B090-A99-05	-	.015 pin length
B003-L3X-11	B097-A99-01 (FD), B097-A99-02 (SB), B099-A99-01, B099-A99-02, B090-A99-05	-	.025 pin length
B024-L3X-02	B097-A99-01 (FD), B097-A99-02 (SB)	-	∅.015 pin, .092 pin length when installed, packaged loose

*Additional body styles and packaging options for GPPO thread-in connectors are available.

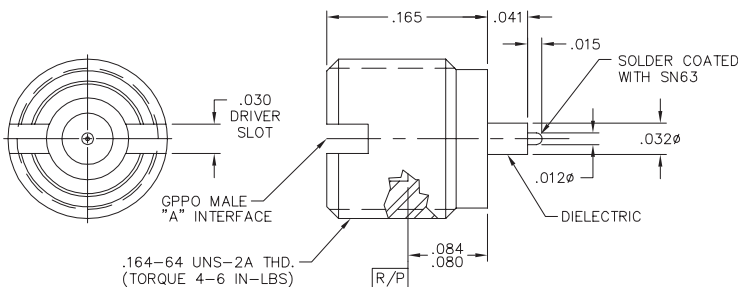

B003-L3X-05



B003-L3X-05

GPPO® Thread-In Shrouds

Male Thread-In Shroud (Accepts Pin Subassembly)

Catalog Number	Recommended Tools	Assembly Procedure	Notes
B003-N3X-01	L091-A99-05, L091-A99-06, A090-A99-07, B097-A99-01 (FD), B097-A99-02 (SB)	AP01-104	Accepts Ø.012 pin subassembly
B003-N3X-02	B097-A99-01 (FD), B097-A99-02 (SB)	-	Accepts Ø.009 pin subassembly

*Additional body styles and packaging options for GPPO® thread-in connectors are available.

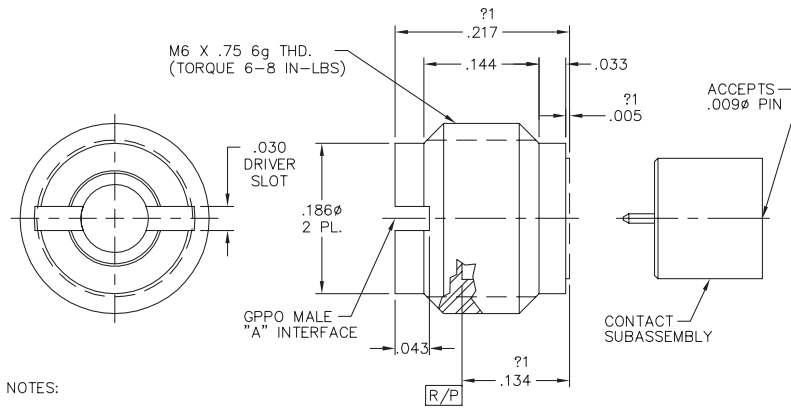

NOTES:
1 WITH CONTACT SUBASSEMBLY INSTALLED



B003-N3X-02

B003-N3X-02

GPPO Solder-On Shrouds

Male Solder-On Shroud with Pin

Catalog Number	Recommended Tools	Assembly Procedure	Notes
B012-L1X-03	B096-A99-01 (FD), B096-A99-02 (SB)	-	Accepts Ø.012 pin (included)
B012-L1X-11	-	-	Accepts Ø.012 pin (included), alignment plug
B012-L1X-11-T	-	-	Accepts Ø.012 pin (included), solder dipped, alignment plug

*Additional body styles and packaging options for GPPO shroud connectors are available.

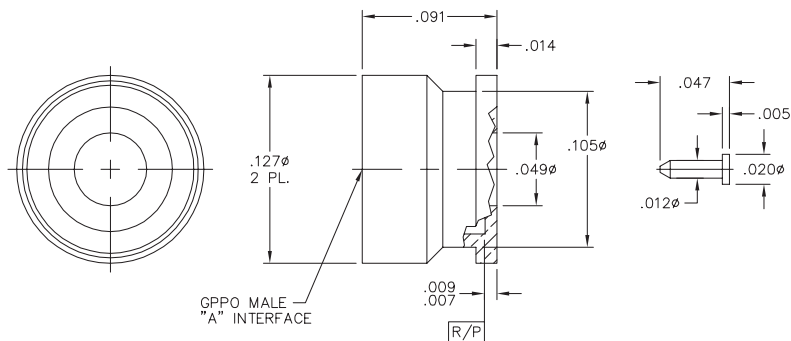

B012-L1X-03

B012-L1X-03

GPPO® Hermetic Shrouds

Male Hermetic Shroud (Full Shroud)

Catalog Number	Recommended Tools	Assembly Procedure	Notes
B007-M4X-01-TAB-R	B096-A99-01 (FD), B096-A99-02 (SB)	-	Radius pin, pin lengths of .030 to .145 in .005 increments
B007-M4X-01-TAB-S	B096-A99-01 (FD), B096-A99-02 (SB)	-	Square pin, pin lengths of .030 to .145 in .005 increments

*Additional body styles and packaging options for GPPO® shroud connectors are available.

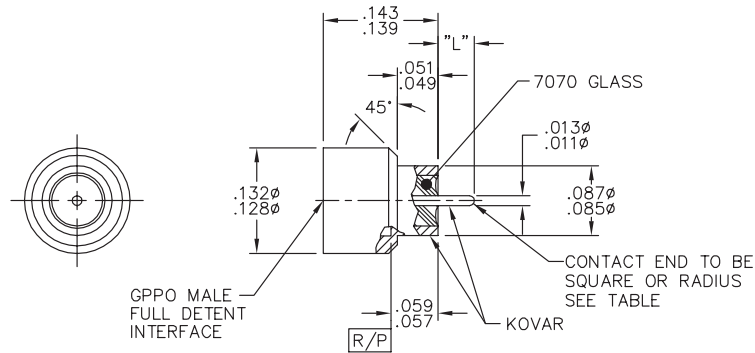

B007-M4X-01-TAB-R



B007-M4X-01-TAB-R

Male Hermetic Shroud (Solder-In)

Catalog Number	Recommended Tools	Assembly Procedure	Notes
B007-L4X-17	B096-A99-01 (FD), B096-A99-02 (SB)	-	
B007-L4X-25-T	B096-A99-01 (FD), B096-A99-02 (SB)	-	Solder dipped
B007-L4X-27-T	B096-A99-01 (FD), B096-A99-02 (SB)	-	Solder dipped

*Additional body styles and packaging options for GPPO shroud connectors are available.

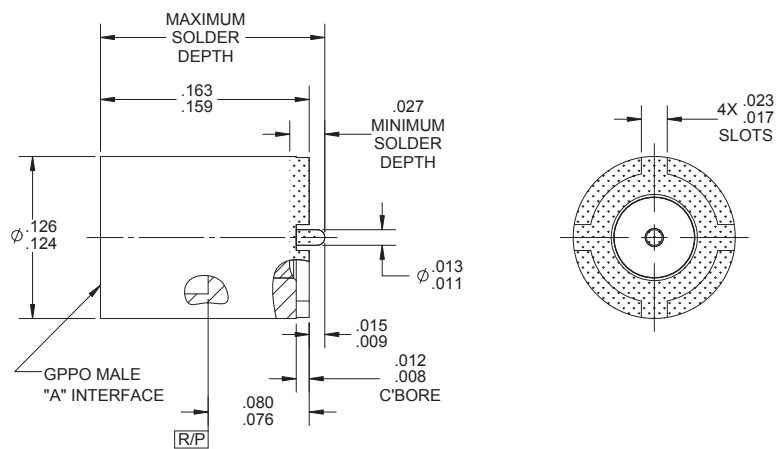

B007-L4X-27-T



B007-L4X-27-T

GPPO® Flange Mounts

Male Flange Mount (Two Hole, No Center Conductor)

Catalog Number	Recommended Tools	Assembly Procedure	Notes
B001-A2X-01	B090-A99-09, B090-A99-01 (FD), B090-A99-02 (SB)	-	Flange diameter $\varnothing.375$ Flange width .125 Hole spacing .282 Hole size $\varnothing.073$
B001-A2X-02	B090-A99-08, B090-A99-01 (FD), B090-A99-02 (SB)	-	Flange diameter $\varnothing.625$ Flange width .150 Hole spacing .481 Hole size $\varnothing.103$

*Additional body styles and packaging options for GPPO® flange-mount connectors are available.

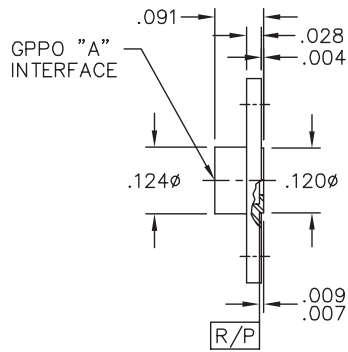
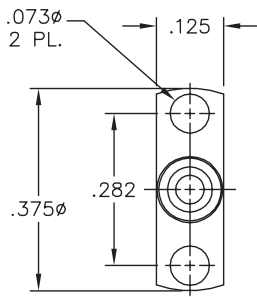

B001-A2X-01

B001-A2X-01

Male Flange Mount (Two Hole, Accepts $\varnothing.012$ Center Conductor)

Catalog Number	Recommended Tools	Assembly Procedure	Notes
B001-N33-02	B097-A99-01	-	Flange diameter $\varnothing.420$ Flange width .177 Hole spacing .310 Hole size $\varnothing.077$

*Additional body styles and packaging options for GPPO flange-mount connectors are available.

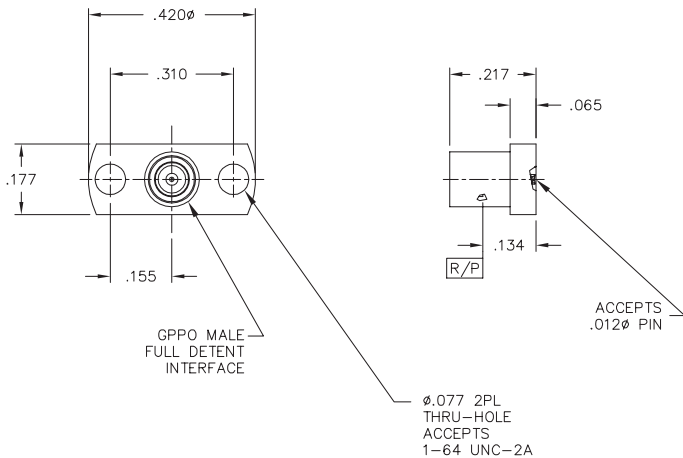

B001-N33-02

B001-N33-02

GPPO® Flange Mounts

Male Flange Mount (Four Hole, Accepts Ø.012 Center Conductor)

Catalog Number	Recommended Tools	Assembly Procedure	Notes
B001-L15-01	B097-A99-02	-	Flange diameter Ø.375 Hole spacing .250 square Hole size Ø.073

*Additional body styles and packaging options for GPPO® flange-mount connectors are available.

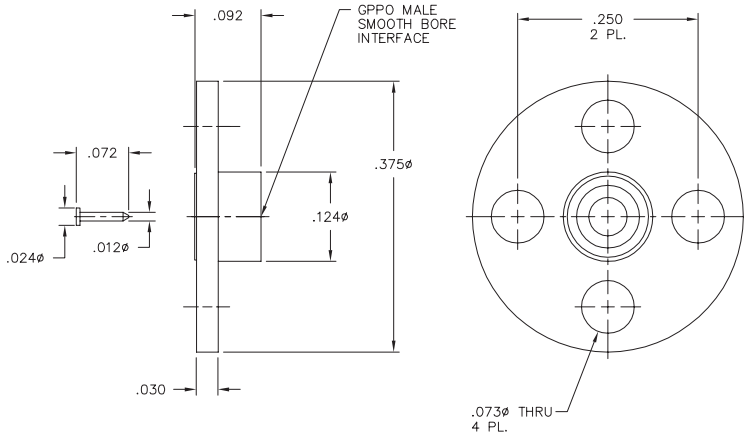

B001-L15-01



B001-L15-01

GPPO® Multiposition Blocks

Male Two-Position Block

Catalog Number	Recommended Tools	Assembly Procedure	Notes
B007-L4X-16	-	-	.130 interface pitch, straight pin

*Additional body styles and packaging options for GPPO® multiposition blocks are available.

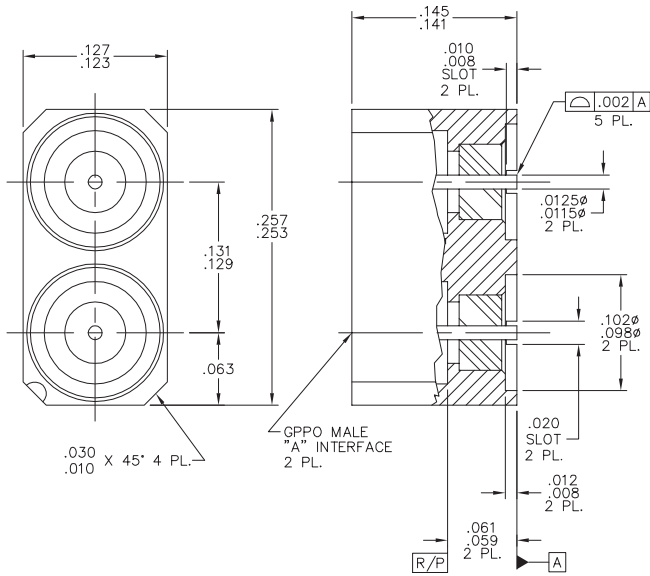

B007-L4X-16



B007-L4X-16

Male Four-Position Block

Catalog Number	Recommended Tools	Assembly Procedure	Notes
B036-T7X-01-T	-	-	.140 interface pitch, straight pin, solder dipped
B036-T47-05	-	-	Varied interface pitch, straight pin

*Additional body styles and packaging options for GPPO multiposition blocks are available.

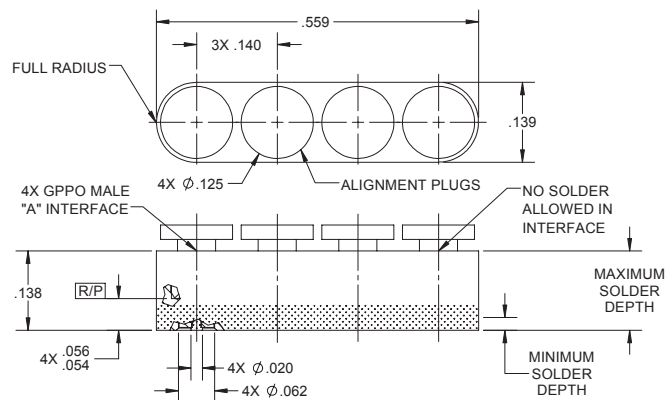

NOTES:
1. ALL DIMENSIONS APPLY PRE-SOLDER DIP UNLESS OTHERWISE SPECIFIED.

B036-T7X-01-T



B036-T7X-01-T

GPPO® Multiposition Blocks

Male Six-Position Block

Catalog Number	Recommended Tools	Assembly Procedure	Notes
B039-P9X-01	-	-	.130 interface pitch, R/A pin
B036-L93-01-T	-	-	.250 interface pitch, straight pin, solder dipped

*Additional body styles and packaging options for GPPO® multiposition blocks are available.

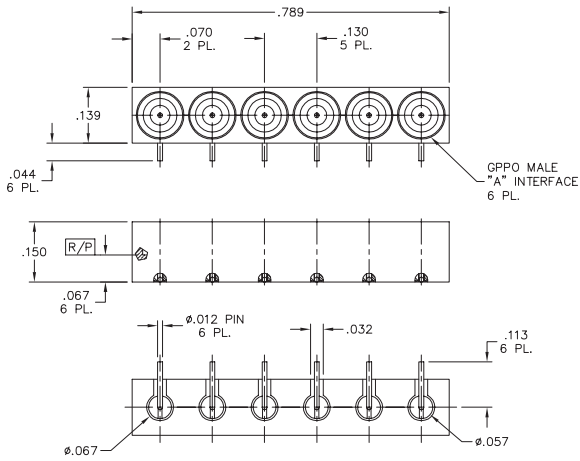

B039-P9X-01



B039-P9X-01

GPPO® Accessories

Pogo Pin

Catalog Number	Recommended Tools	Assembly Procedure	Notes
B003-T93-01	-	-	

*Additional body styles and packaging options for GPPO® accessories are available.

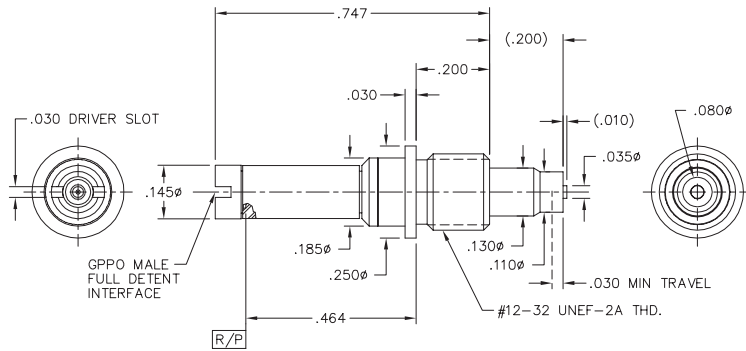

B003-T93-01



B003-T93-01

Female 50 Ohm Load

Catalog Number	Recommended Tools	Assembly Procedure	Notes
B055-A11-01	B098-A99-03	-	Test-grade load
B055-A11-02	B098-A99-03	-	Field-grade load
B055-A11-05	B098-A99-03	-	R/A load
B055-A11-06	B098-A99-03	-	½ watt

*Additional body styles and packaging options for GPPO accessories are available.

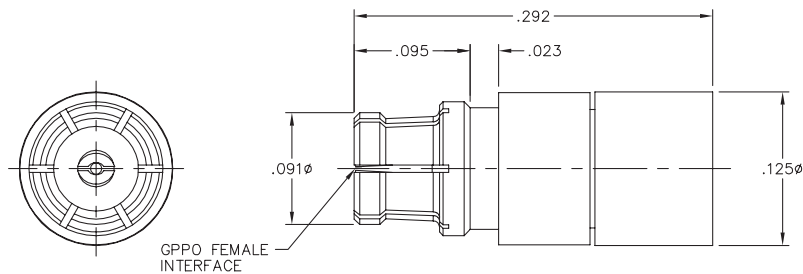

B055-A11-01



B055-A11-01

GPPO® Accessories

Male 50 Ohm Load

Catalog Number	Recommended Tools	Assembly Procedure	Notes
B055-A1X-01	B098-A99-03	-	Test-grade load
B055-A1X-02	B098-A99-03	-	Field-grade load

*Additional body styles and packaging options for GPPO® accessories are available.

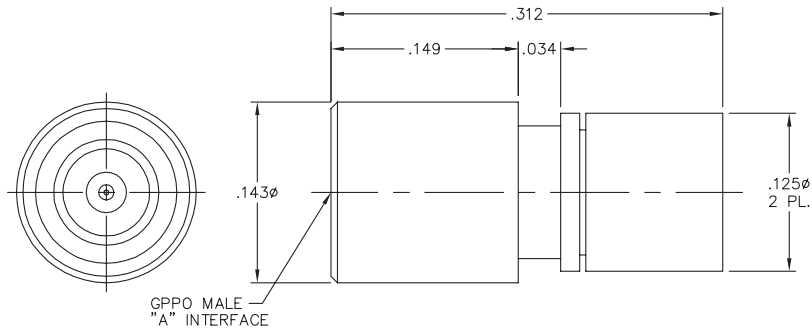

B055-A1X-01



B055-A1X-01

Female Short

Catalog Number	Recommended Tools	Assembly Procedure	Notes
B055-A11-08	B098-A99-03	-	

*Additional body styles and packaging options for GPPO accessories are available.

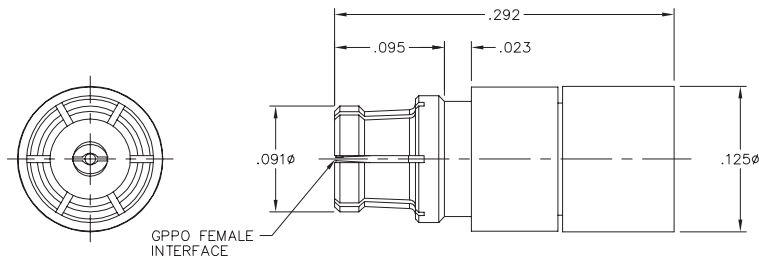

B055-A11-08



B055-A11-08

GPPO® Accessories

Male Short

Catalog Number	Recommended Tools	Assembly Procedure	Notes
B055-A1X-05	B098-A99-03	-	

*Additional body styles and packaging options for GPPO® accessories are available.

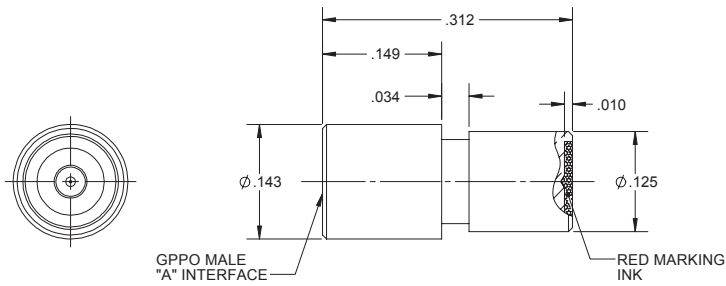

B055-A1X-05



B055-A1X-05

50 Ohm Hermetic Seal

Catalog Number	Recommended Tools	Assembly Procedure	Notes
Y007-L42-01	-	-	.125 pin length
Y007-L42-05	-	-	.091 pin length

*Additional body styles and packaging options for GPPO accessories are available.

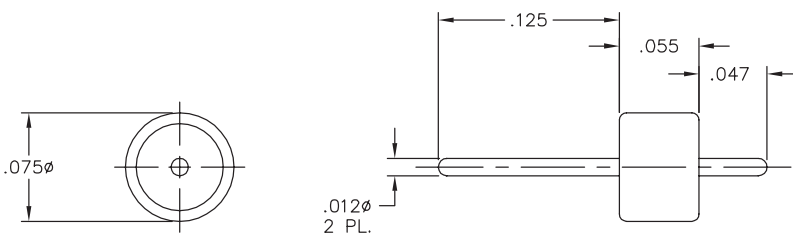

Y007-L42-01



Y007-L42-01

GPPO® Accessories

Interface Plug (Alignment Plug)

Catalog Number	Recommended Tools	Assembly Procedure	Notes
Y072-A09-04	-	-	Full detent
Y072-A09-05	-	-	Smooth bore

*Additional body styles and packaging options for GPPO® accessories are available.

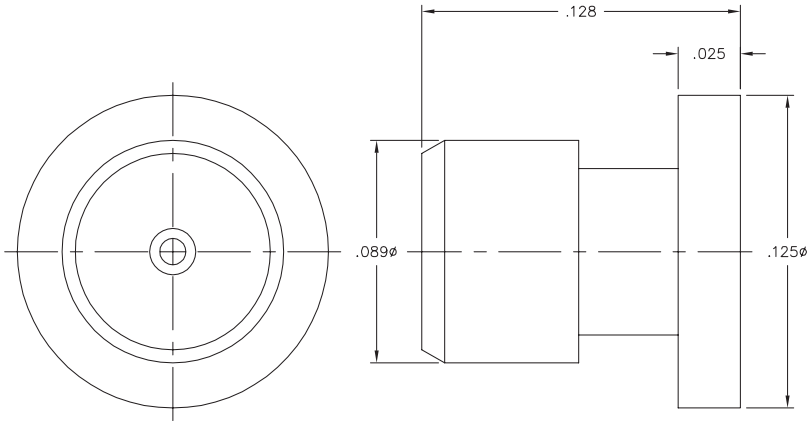

Y072-A09-05



Y072-A09-05



G3PO™ Products

- Center-to-center spacing of 0.085-in and board-to-board spacing of 0.120-in are available for increased package density
- Frequency from DC to 100 GHz
- Designed to accommodate both radial and axial misalignment with negligible voltage standing wave ratio (VSWR) change
- Adapters available to 1.85 mm and sub-miniature, part A (SMA)



G3PO™ Specifications

General Characteristics

Impedance	50 Ohms nominal
Frequency range	DC to 100 GHz
Temperature range	-55°C to 165°C

Electrical Characteristics

VSWR	1.10: 1 to 26.5 GHz typical; 1.25: 1 typical to 65 GHz
Insertion loss	.03 √f (GHz)
DWV @ sea level	250 V _{rms}
Insulation resistance	3,500 megohms minimum
Contact resistance	
Outer conductor	2 milliohms maximum
Inner conductor	6 milliohms maximum
RF leakage	-80 dB (typical mated pair)

Mechanical Characteristics

Mate/demate cycles	Full detent (FD) - 100 minimum; smooth bore - 500 minimum
Force to engage/disengage	FD - 2.5 lbs typical/4.5 lbs typical; SB - 1.2 lbs typical/1.0 lbs typical
Tolerated misalignment	
Radial	+/-0.010
Axial	0.010 (flush to 0.010 from the reference plane)

Environmental Characteristics

Thermal shock	MIL-STD-202, Method 107, Condition B
Salt spray	MIL-STD-202, Method 101
Vibration	MIL-STD-202, Method 204
Shock	MIL-STD-202, Method 213, Condition I
Moisture resistance	MIL-STD-202, Method 106, except Step 7B

Materials (typical)

Bodies	Beryllium copper per ASTM B196 and or/ASTM B197
Outer contacts	Beryllium copper per ASTM B196 and or/ASTM B197
Center contacts	Beryllium copper per ASTM B196 and or/ASTM B197
Insulators	PTFE fluorocarbon per ASTM D1710
Insulators	Polyamide-imide per ASTM D5204

Finish (typical)

Bodies	Gold plated per MIL-G-45204, Type I, Grade C, Class 1, over nickel plate per SAE AMS-QQ-N-290
Contacts	Gold plated per MIL-G-45204, Type I, Grade C, Class 1, over nickel plate per SAE AMS-QQ-N-290

G3PO™ Blind Mate Interconnects

Female Blind Mate Interconnect (Bullet) – Standard

Catalog Number	Length (inches)	Recommended Tools	Assembly Procedure	Notes
R1R1-0001-01	.098	R098-A99-02	-	
R1R1-0001-27	.315	R098-A99-02	-	
R1R1-0001-26	.531	R098-A99-02	-	

*Additional lengths available upon request.

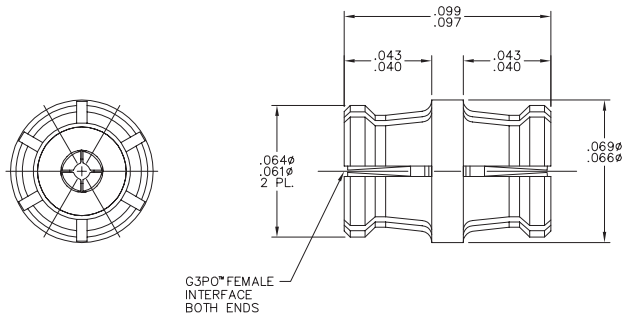

R1R1-0001-01



R1R1-0001-01



R1R1-0001-26

Female Blind Mate Interconnect (Bullet) – XD Interface

Catalog Number	Length (inches)	Recommended Tools	Assembly Procedure	Notes
R1R1-0001-21-0178	.178	R098-A99-02	-	
R1R1-0001-31-1000	1.000	R098-A99-02	-	
R1R1-0001-19	1.687	R098-A99-02	-	

*Additional lengths available upon request.

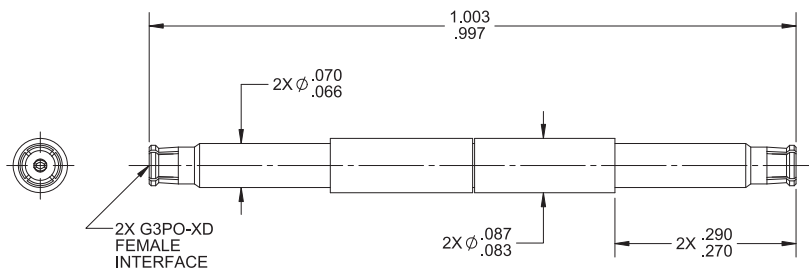

R1R1-0001-31-1000



R1R1-0001-31-1000

G3PO™ Blind Mate Interconnects

Female Blind Mate Interconnect (Bullet) – Spring Loaded/Self-Adjusting

Catalog Number	Relaxed Length (inches)	Compressed Length (inches)	Recommended Tools	Assembly Procedure	Notes
R1R1-0009-03	.646	.596	R098-A99-02	-	

*O-rings and gaskets are for alignment only and are not to be used for shielding applications.

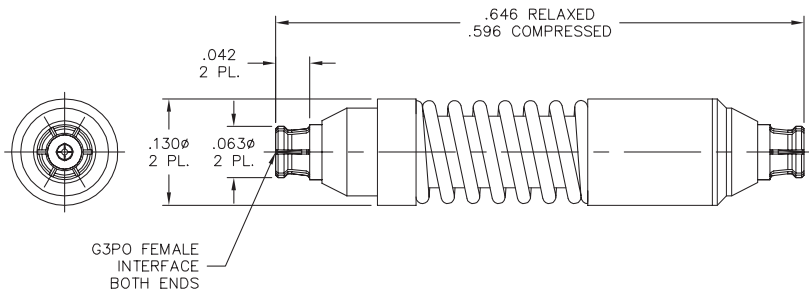

R1R1-0009-03



R1R1-0009-03

G3PO™ to .047 Cable Connectors

Female Straight to .047 Semi-Rigid (S/R) Cable

Catalog Number	Recommended Tools	Assembly Procedure	Notes
R014-B11-01	R096-A95-01, A096-A99-04, L096-A99-02, R098-A99-01	AP01-157	
R014-B11-02	R096-A95-01, A096-A99-04, L096-A99-02, R098-A99-01	AP01-157	
R014-B11-03	R096-A95-01, A096-A99-04, L096-A99-02, R098-A99-01	AP01-157	
R014-B71-01	R096-A95-01, A096-A99-04, L096-A99-02, R098-A99-01	AP01-169	

*Semi-flex cable can be substituted in place of .047 semi-rigid.
 **Additional cable options for G3PO™ female straight connectors are available.

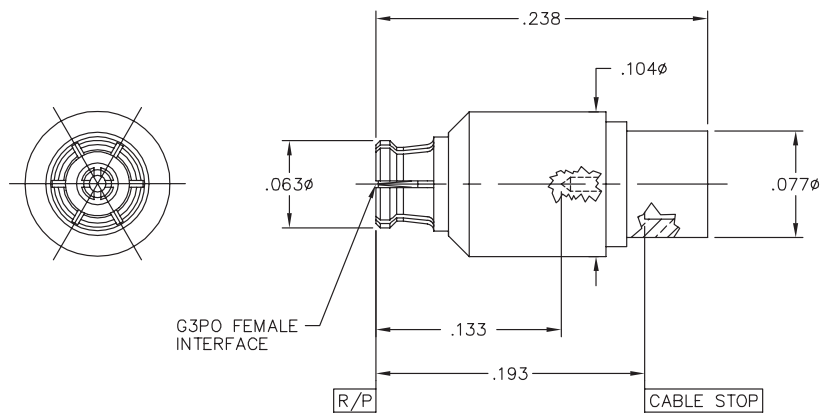

R014-B11-01



R014-B11-01

Male Straight to .047 Semi-Rigid (S/R) Cable

Catalog Number	Recommended Tools	Assembly Procedure	Notes
R014-B1X-01	R096-A23-01 (FD), R096-A25-01 (SB) A096-A99-04, L096-A99-02	AP01-158	

*Semi-flex cable can be substituted in place of .047 semi-rigid.
 **Additional cable options for G3PO male snap-in connectors are available.

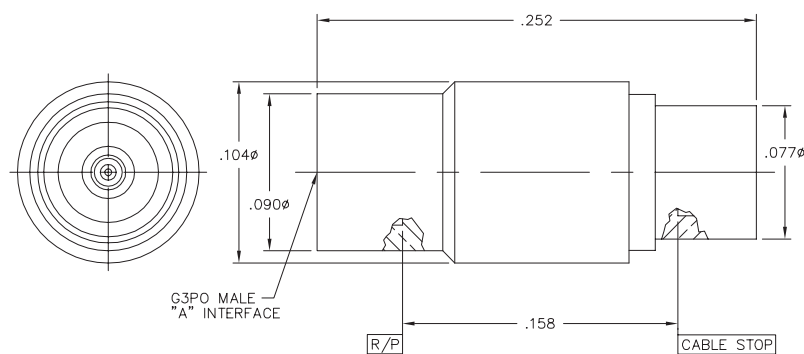

R014-B1X-01



R014-B1X-01

G3PO™ to .047 Cable Connectors

Female Right-Angle (R/A) to .047 Semi-Rigid (S/R) Cable

Catalog Number	Recommended Tools	Assembly Procedure	Notes
R015-B11-01	R096-A95-01, A096-A99-09, L096-A99-02	AP01-159	
R015-B11-02	R096-A95-01, A096-A99-09, L096-A99-02	AP01-164	

*Semi-flex cable can be substituted in place of .047 semi-rigid.
 **Additional cable options for G3PO™ female right-angle connectors are available.

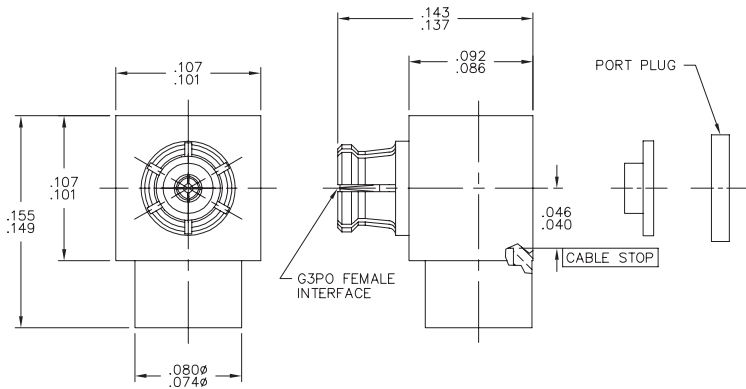

R015-B11-01



R015-B11-01

Male Bulkhead to .047 Semi-Rigid (S/R) Cable

Catalog Number	Recommended Tools	Assembly Procedure	Notes
R014-B8X-01	R096-A23-01 (FD), R096-A25-01 (SB), A096-A99-04, L096-A99-02	AP01-174	
R014-D3X-01	R096-A23-01 (FD), R096-A25-01 (SB), A096-A99-04, L096-A99-02	AP01-173	

*Semi-flex cable can be substituted in place of .047 semi-rigid.
 **Additional cable options for G3PO male bulkhead connectors are available.

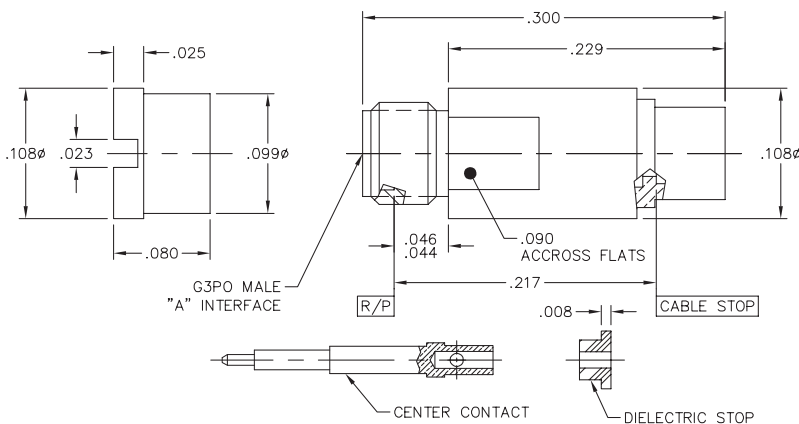

R014-B8X-01



R014-B8X-01

G3PO™ to .047 Cable Connectors

Female Snap-In to .047 Semi-Rigid (S/R) Cable

Catalog Number	Recommended Tools	Assembly Procedure	Notes
R016-B11-01	R096-A95-01, A096-A99-04, L096-A99-02	-	

*Semi-flex cable can be substituted in place of .047 semi-rigid.
 **Additional cable options for G3PO™ female snap-in connectors are available.

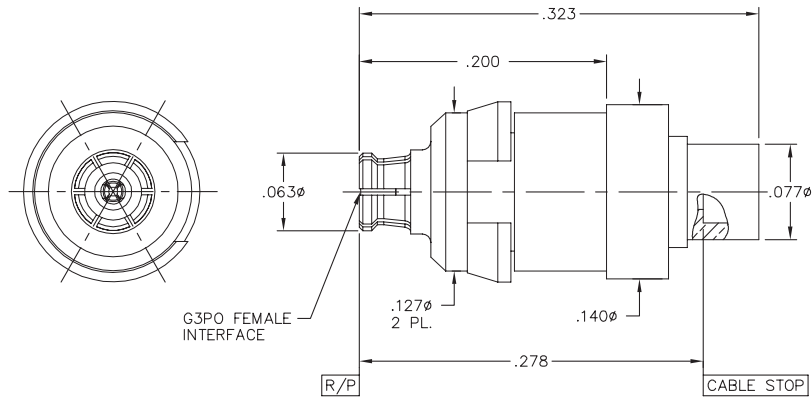

R016-B11-01



R016-B11-01

Male Flange-Mount to .047 Semi-Rigid (S/R) Cable

Catalog Number	Recommended Tools	Assembly Procedure	Notes
R001-B3X-01	R096-A23-01 (FD), R096-A25-01 (SB), A096-A99-04, L096-A99-02	AP01-158	

*Semi-flex cable can be substituted in place of .047 semi-rigid.
 **Additional cable options for G3PO male flange-mount connectors are available.

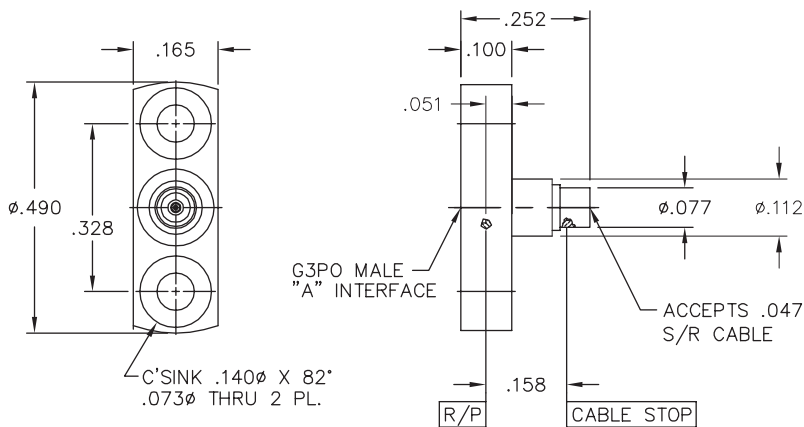

R001-B3X-01



R001-B3X-01

G3PO™ Vertical-Launch PCB Mounts

Male Straight to PCB, Round Body

Catalog Number	Recommended Tools	Assembly Procedure	Notes
R008-L1X-01	-	-	.060 leg length, alignment plug
R008-L1X-02	-	-	No legs
R008-L1X-02-T	-	-	No legs, solder dipped
R008-L1X-02-T@T13	-	-	No legs, solder dipped, on tape and reel
R008-L1X-08-T	-	-	.015 alignment pin length, alignment plug, solder dipped
R008-L1X-08-T@T13	-	-	.015 alignment pin length, alignment plug, solder dipped, on tape and reel
R007-T4X-02	-	-	No legs

*Additional leg length, body styles, and packaging options for G3PO™ male straight to PCB connectors are available.

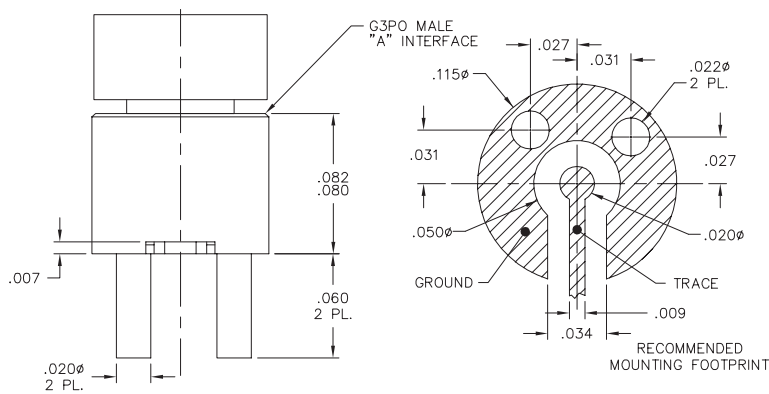

R008-L1X-01



R008-L1X-01

Male Straight to PCB, Right-Angle (R/A) Center Conductor (C/C)

Catalog Number	Recommended Tools	Assembly Procedure	Notes
R012-P9X-01	-	-	

*Additional leg length, body styles, and packaging options for G3PO male straight to PCB connectors are available.

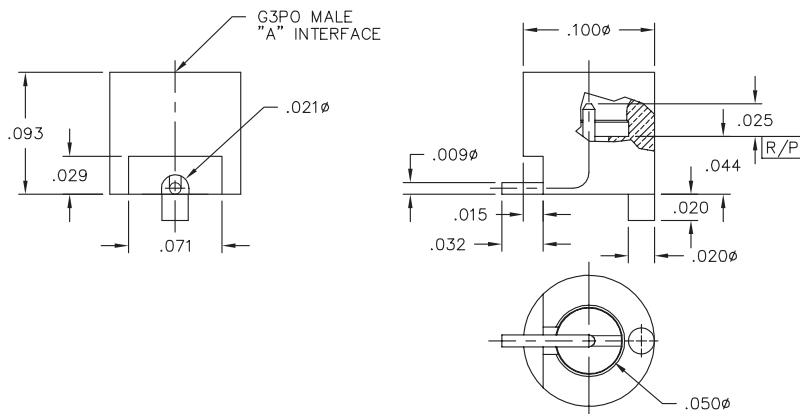

R012-P9X-01



R012-P9X-01

G3PO™ Right-Angle PCB Mounts

Male Right-Angle to PCB

Catalog Number	Recommended Tools	Assembly Procedure	Notes
R013-P7X-01-T	-	-	

*Additional leg length, body styles, and packaging options for G3PO™ male right-angle to PCB connectors are available.

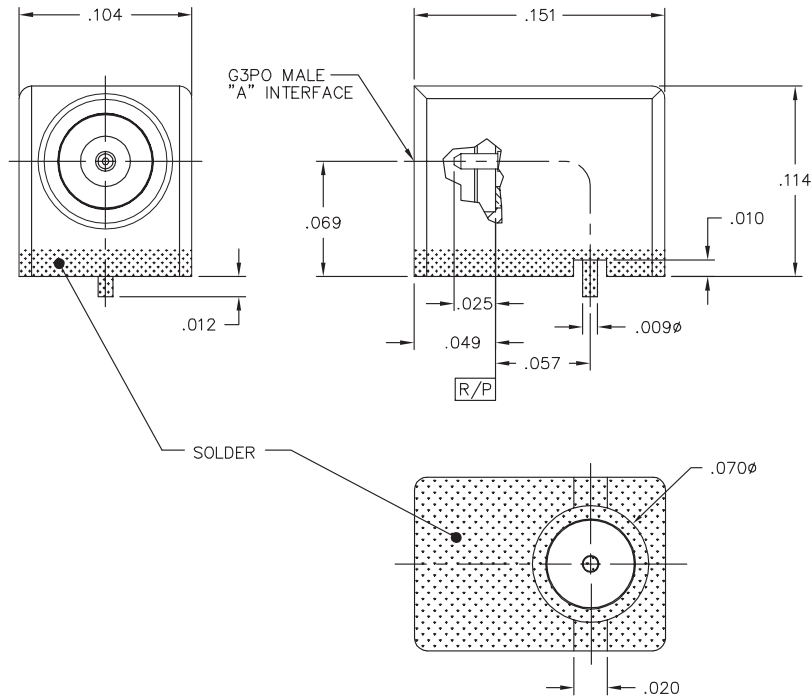

R013-P7X-01-T

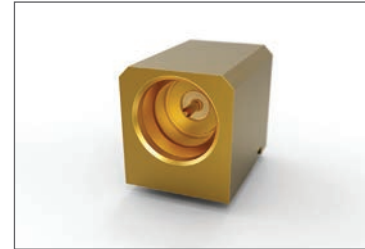

R013-P7X-01-T

G3PO™ Edge Mounts

Male Edge Flush Mount

Catalog Number	Recommended Tools	Assembly Procedure	Notes
R010-L1X-03	-	-	

*Additional body styles and packaging options for G3PO™ male edge-mount to PCB connectors are available.

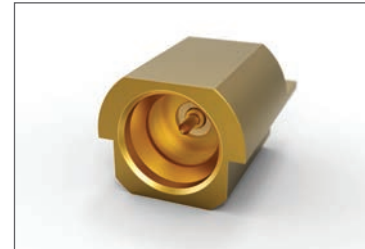
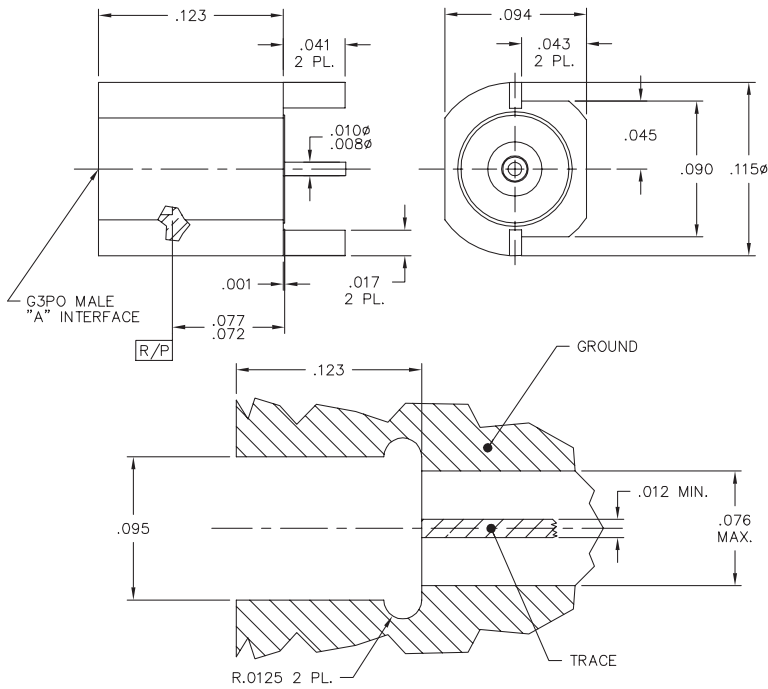

R010-L1X-03

R010-L1X-03

Male Edge Mount

Catalog Number	Recommended Tools	Assembly Procedure	Notes
R010-L1X-01	-	-	

*Additional body styles and packaging options for G3PO male edge-mount to PCB connectors are available.

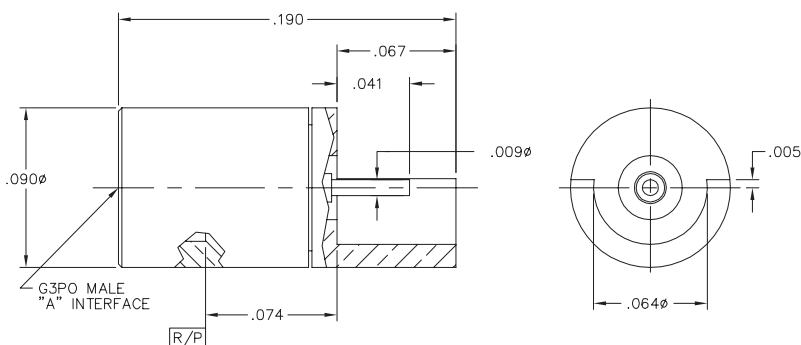

R010-L1X-01

R010-L1X-01

G3PO™ Thread-In Shrouds

Male Thread-In Shroud (With Pin)

Catalog Number	Recommended Tools	Assembly Procedure	Notes
R003-L3X-01	-	-	

*Additional body styles and packaging options for G3PO™ shroud connectors are available.

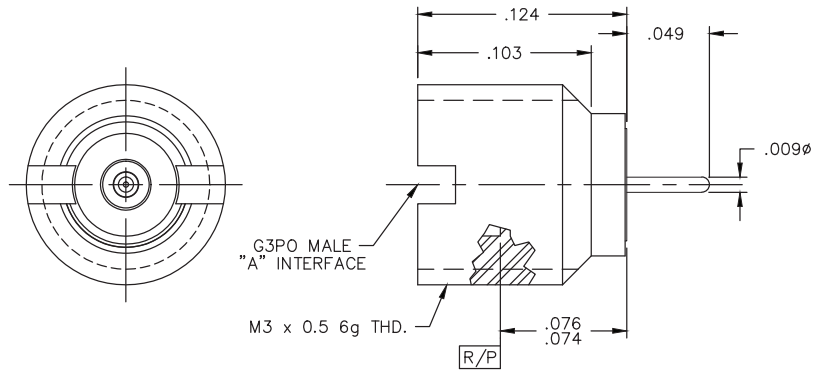

R003-L3X-01



R003-L3X-01

G3PO™ Solder-On Shrouds

Male Solder-On Shroud with Pin

Catalog Number	Recommended Tools	Assembly Procedure	Notes
R012-T95-04	R096-A25-01	-	Accepts Y071-T92-02 pin

*Additional body styles and packaging options for G3PO™ shroud connectors are available.

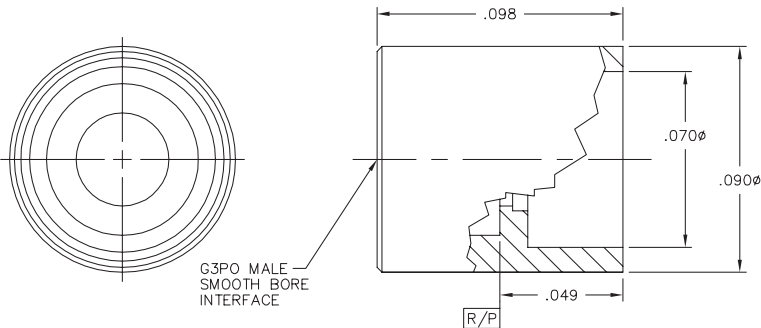

R012-T95-04

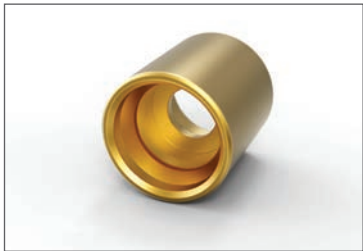

R012-T95-04

G3PO™ Hermetic Shrouds

Male Hermetic Shroud

Catalog Number	Recommended Tools	Assembly Procedure	Notes
R007-L4X-05-TAB-R	-	-	Radius pin, pin lengths of .025 to .075 in .005 increments
R007-L4X-05-TAB-S	-	-	Square pin, pin lengths of .025 to .075 in .005 increments

*Additional body styles and packaging options for G3PO™ shroud connectors are available.

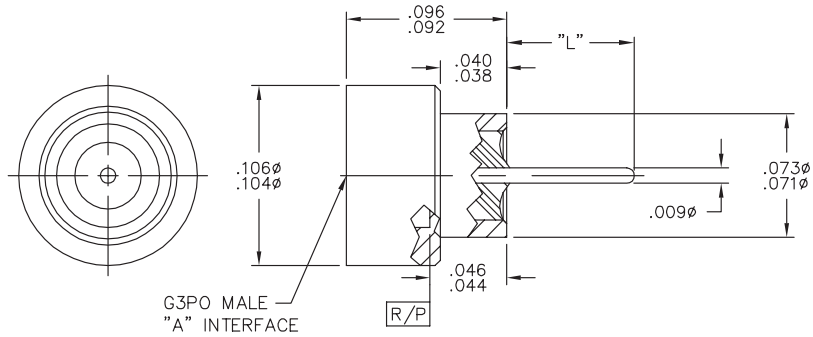

R007-L4X-05-TAB-R



R007-L4X-05-TAB-R

Male Hermetic Shroud (Solder-In)

Catalog Number	Recommended Tools	Assembly Procedure	Notes
R007-L4X-11-T	-	-	SI Interface, solder dipped

*Additional body styles and packaging options for G3PO shroud connectors are available.

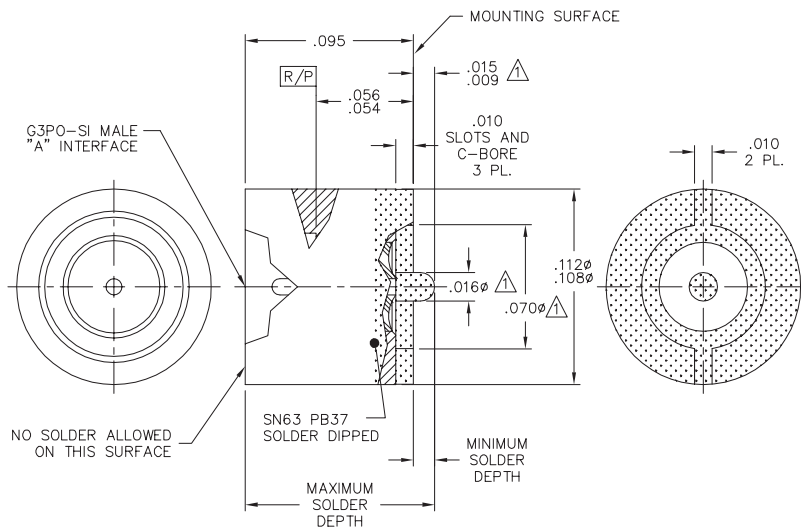

R007-L4X-11-T

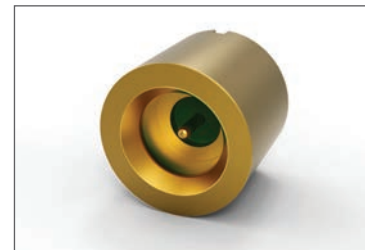

R007-L4X-11-T

G3PO™ Multiposition Blocks

Male Two-Position Block

Catalog Number	Recommended Tools	Assembly Procedure	Notes
R032-L4X-04-T	-	-	.115 interface pitch, solder dipped
R032-L4X-07-T	-	-	SI interface, .095 interface pitch, solder dipped
R032-L46-12-T	-	-	XD interface, .125 interface pitch, solder dipped

*Additional body styles and packaging options for G3PO™ multiposition blocks are available.

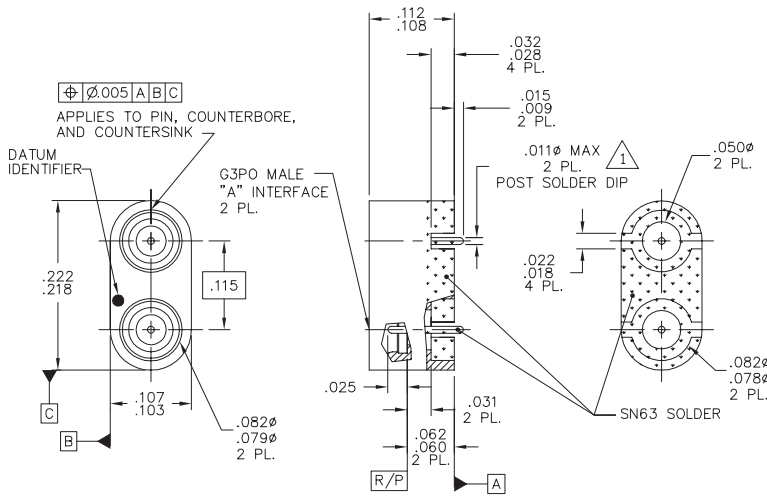

R032-L4X-04-T



R032-L4X-04-T

Male Three-Position Block

Catalog Number	Recommended Tools	Assembly Procedure	Notes
R036-T4X-18	-	-	.160 interface pitch

*Additional body styles and packaging options for G3PO multiposition blocks are available.

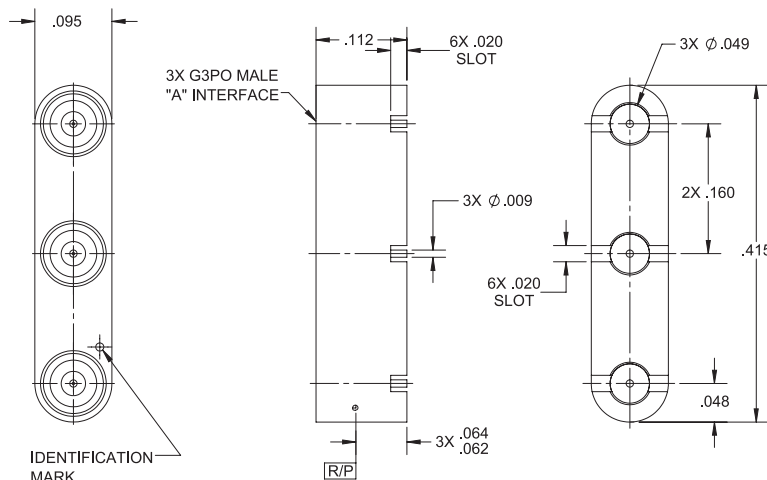

R036-T4X-18



R036-T4X-18

G3PO™ Multiposition Blocks

Male Four-Position Block

Catalog Number	Recommended Tools	Assembly Procedure	Notes
R036-T4X-19	-	-	.160 interface pitch

*Additional body styles and packaging options for G3PO™ multiposition blocks are available.

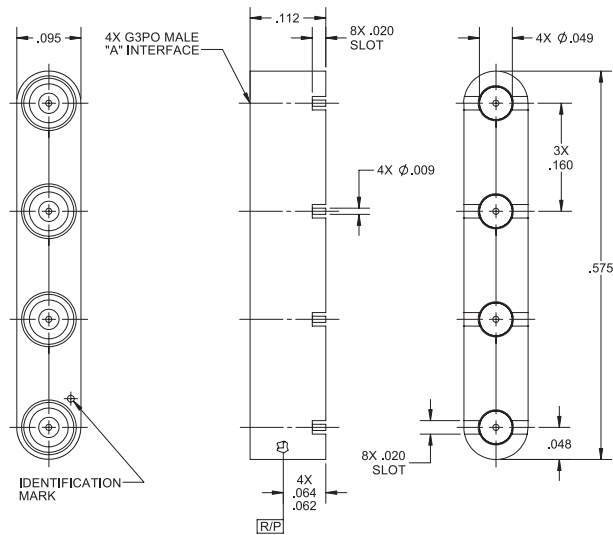

R036-T4X-19

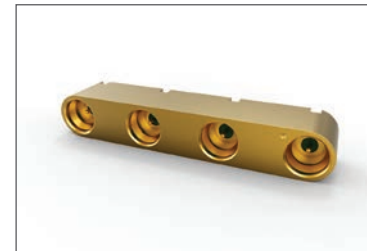

R036-T4X-19

Male Six-Position Block

Catalog Number	Recommended Tools	Assembly Procedure	Notes
R036-T4X-17	-	-	.140 interface pitch
R036-T4X-22	-	-	.180 interface pitch

*Additional body styles and packaging options for G3PO multiposition blocks are available.

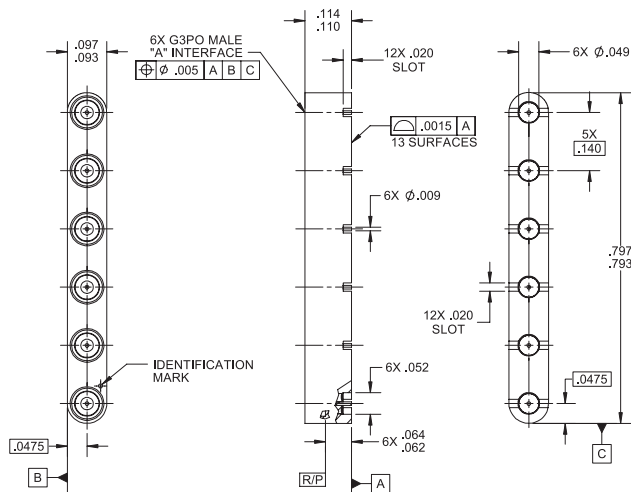

R036-T4X-17

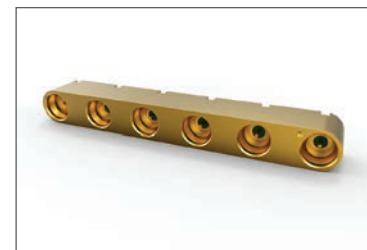

R036-T4X-17

G3PO™ Multiposition Blocks

Male Eight-Position Block

Catalog Number	Recommended Tools	Assembly Procedure	Notes
R032-L4X-10	-	-	.088 interface pitch, hermetic
R032-L4X-14	-	-	.088 interface pitch, hermetic

*Additional body styles and packaging options for G3PO™ multiposition blocks are available.

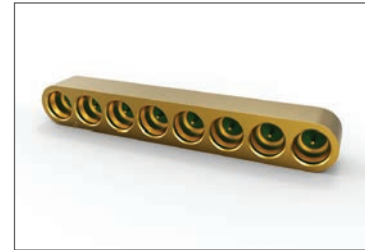
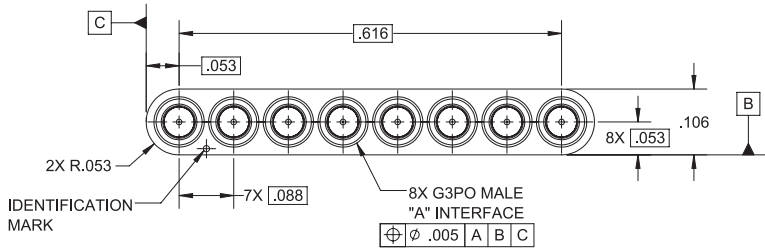

R032-L4X-14

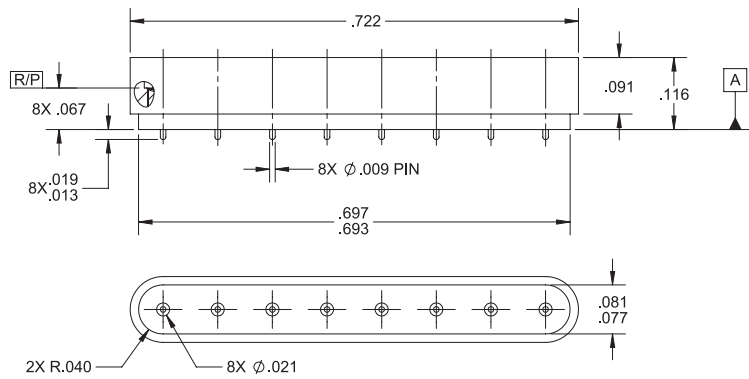

R032-L4X-14

G3PO™ Multiposition Blocks

Male 16-Position Block

Catalog Number	Recommended Tools	Assembly Procedure	Notes
R033-B53-01	L096-A99-12	AP01-146	.230 interface pitch, micro-D receptacle to .047 flex cable, mates with R032-L95-01
R032-L95-01	-	-	.230 interface pitch, micro-D plug board mount, mates with R033-B53-01
R036-T93-02	-	-	.160 interface pitch, includes pins and interface plugs
R036-T95-03	-	-	.160 interface pitch, includes pins and interface plugs

*Additional body styles and packaging options for G3PO™ multiposition blocks are available.

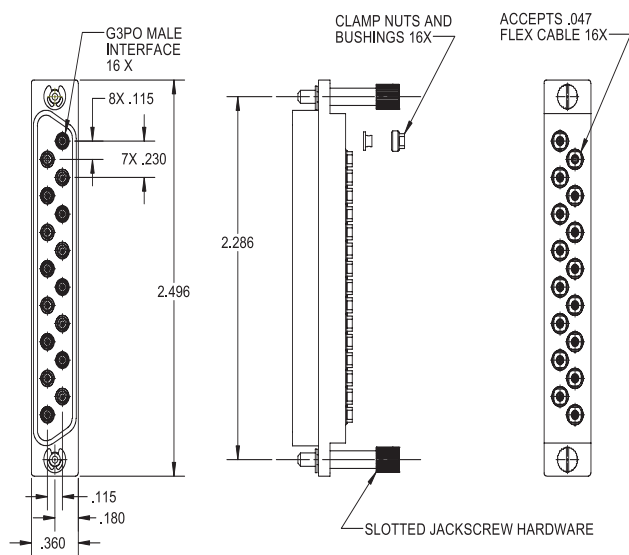

R033-B53-01



R033-B53-01



R032-L95-01

G3PO™ Accessories

Pogo Pin

Catalog Number	Recommended Tools	Assembly Procedure	Notes
R003-T93-01	-	-	

*Additional body styles and packaging options for G3PO™ accessories are available.

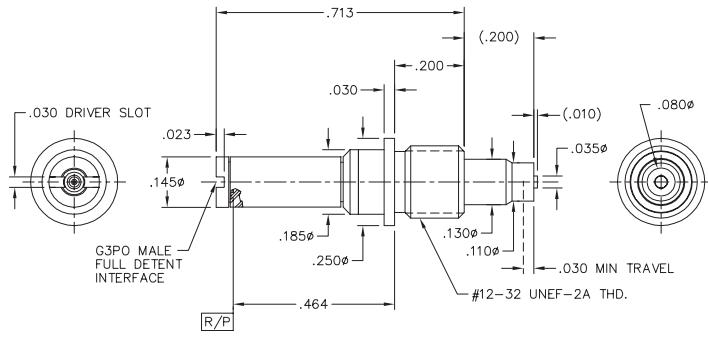

R003-T93-01



R003-T93-01

Female 50 Ohm Load

Catalog Number	Recommended Tools	Assembly Procedure	Notes
R055-A11-01	R098-A99-02	-	
R055-A11-02	R098-A99-02	-	

*Additional body styles and packaging options for G3PO accessories are available.

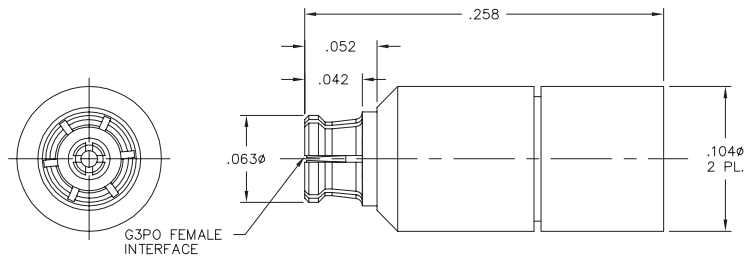

R055-A11-01



R055-A11-01

G3PO™ Accessories

Male 50 Ohm Load

Catalog Number	Recommended Tools	Assembly Procedure	Notes
R055-A1X-01	-	-	

*Additional body styles and packaging options for G3PO™ accessories are available.

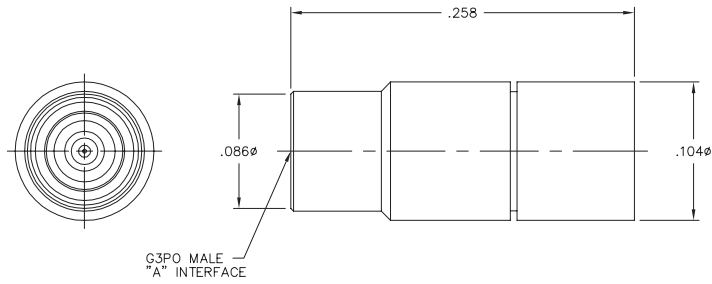

R055-A1X-01



R055-A1X-01

Pin

Catalog Number	Recommended Tools	Assembly Procedure	Notes
Y071-T92-02	-	-	

*Additional body styles and packaging options for G3PO accessories are available.

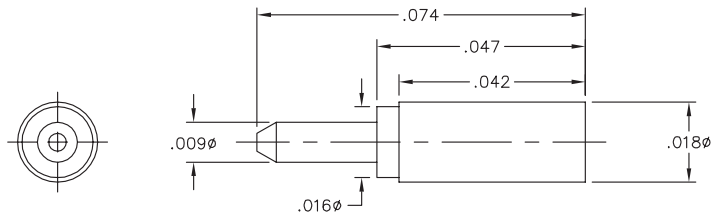

Y071-T92-02



Y071-T92-02

G3PO™ Accessories

Interface Plug (Alignment Plug)

Catalog Number	Recommended Tools	Assembly Procedure	Notes
Y072-A0X-03	-	-	

*Additional body styles and packaging options for G3PO™ accessories are available.

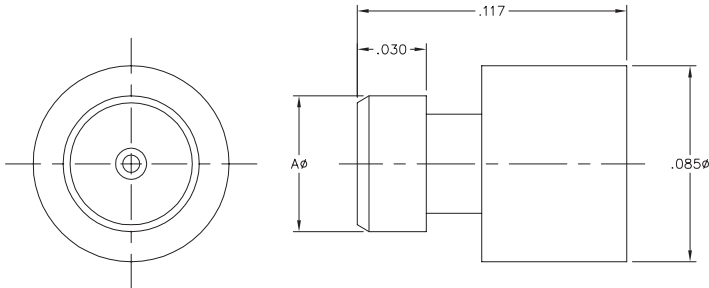

Y072-A0X-03



Y072-A0X-03



G4PO™ Products

- Center-to-center spacing of 0.070-in and board-to-board spacing of 0.090-in are available for increased package density
- Frequency from DC to 60 GHz
- Designed to accommodate both radial and axial misalignment with negligible voltage standing wave ratio (VSWR) change

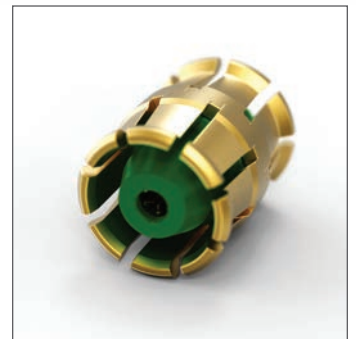

G4PO™ Specifications

General Characteristics

Impedance	50 Ohms nominal
Frequency range	DC to 60 GHz
Temperature range	-55°C to 165°C

Electrical Characteristics

VSWR	1.15:1 to 15 GHz typical; 1.25:1 to 60 GHz typical
Insertion loss	.03 \sqrt{f} (GHz)
DWV @ sea level	250 V_{rms}
Insulation resistance	3,500 megohms minimum
Contact resistance	
Outer conductor	2 milliohms maximum
Inner conductor	6 milliohms maximum
RF leakage	-80 dB (typical mated pair)

Mechanical Characteristics

Mate/demate cycles	Full detent (FD) - 100 minimum; smooth bore - 500 minimum
Force to engage/disengage	Full detent (FD) - .65 lbs typical/2.2 lbs typical; SB - .20 lb typical/.15 lb typical
Tolerated misalignment	
Radial	+/-0.005
Axial	0.007 (flush to 0.007 from the reference plane)

Environmental Characteristics

Thermal shock	MIL-STD-202, Method 107, Condition B
Salt spray	MIL-STD-202, Method 101
Vibration	MIL-STD-202, Method 204
Shock	MIL-STD-202, Method 213, Condition I
Moisture resistance	MIL-STD-202, Method 106, except Step 7B

Materials (typical)

Bodies	Beryllium copper per ASTM B196 and/or ASTM B197
Outer contacts	Beryllium copper per ASTM B196 and/or ASTM B197
Center contacts	Beryllium copper per ASTM B196 and/or ASTM B197
Insulators	PTFE fluorocarbon per ASTM D1710
Insulators	Polyamide-imide per ASTM D5204

Finish (typical)

Bodies	Gold plated per MIL-G-45204, Type I, Grade C, Class 1, over nickel plate per SAE AMS-QQ-N-290
Contacts	Gold plated per MIL-G-45204, Type I, Grade C, Class 1, over nickel plate per SAE AMS-QQ-N-290

G4PO™ Blind Mate Interconnects

Female Blind Mate Interconnect (Bullet) – Standard

Catalog Number	Length (inches)	Recommended Tools	Assembly Procedure	Notes
S1S1-0001-01	.065	S094-A99-01 install, S095-A99-01 removal	-	
S1S1-0001-01-100	.100	S094-A99-01 install, S095-A99-01 removal	-	
S1S1-0001-03-105	.105	S094-A99-01 install, S095-A99-01 removal	-	
S1S1-0001-03-110	.110	S094-A99-01 install, S095-A99-01 removal	-	
S1S1-0001-03-115	.115	S094-A99-01 install, S095-A99-01 removal	-	
S1S1-0001-03-120	.120	S094-A99-01 install, S095-A99-01 removal	-	
S1S1-0001-03-200	.200	S094-A99-01 install, S095-A99-01 removal	-	
S1S1-0001-03-250	.250	S094-A99-01 install, S095-A99-01 removal	-	
S1S1-0001-03-400	.400	S094-A99-01 install, S095-A99-01 removal	-	

*Additional lengths available upon request.

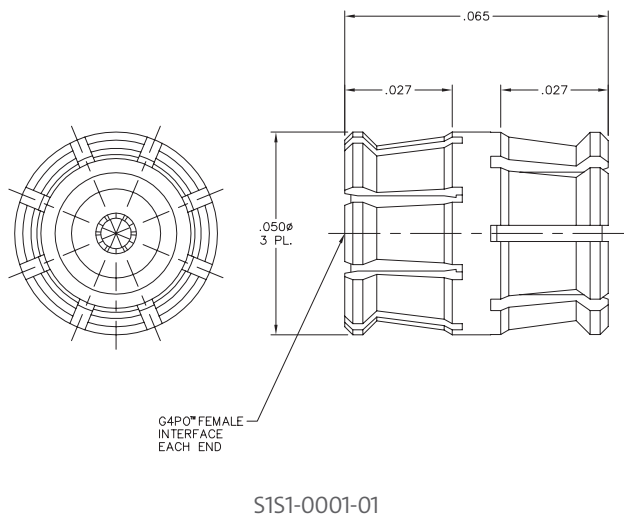

S1S1-0001-01



S1S1-0001-03-400

G4PO™ to .041 Cable Connectors

G4PO™ Cable Assemblies to .041 Flex Cable

Catalog Number	Recommended Tools	Assembly Procedure	Notes
2-S1A-S1A-16-L-0	-	-	G4PO female straight to G4PO female straight, "L" denotes length of cable assembly in inches
2-S1A-D1A-16-L	-	-	G4PO female straight to 2.92 mm jack straight, "L" denotes length of cable assembly in inches
2-S1A-S1C-16-L	-	-	G4PO female straight to G4PO female R/A, "L" denotes length of cable assembly in inches
2-S1C-S1C-16-L	-	-	G4PO female R/A to G4PO female R/A, "L" denotes length of cable assembly in inches
2-S1C-D1A-16-L	-	-	G4PO female R/A to 2.92 mm jack straight, "L" denotes length of cable assembly in inches

*Additional cable options for G4PO female straight connectors are available.

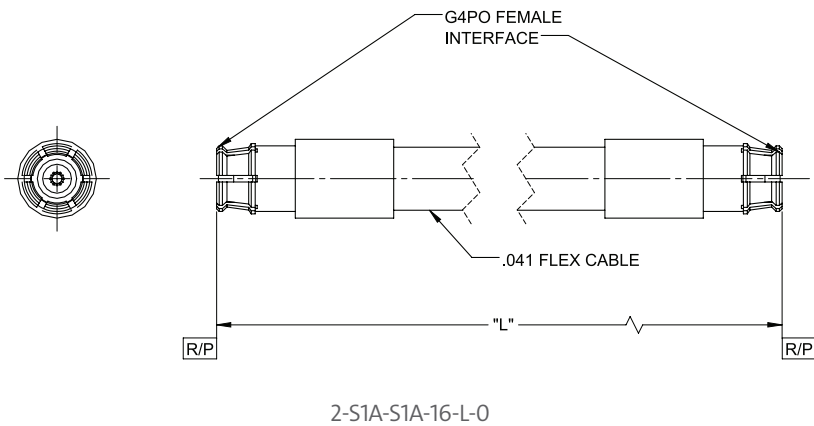

2-S1A-S1A-16-L-0

G4PO™ Vertical Launch PCB Mounts

Male Straight to PCB, Round Body

Catalog Number	Recommended Tools	Assembly Procedure	Notes
S008-L93-03	-	-	Full detent SI interface, alignment plug
S008-L93-03-T	-	-	Full detent SI interface, alignment plug, solder dipped
S008-L93-03-T@T13	-	-	Full detent SI interface, alignment plug, solder dipped, on tape and reel
S008-L95-03	-	-	Smooth bore XD interface, alignment plug
S008-L95-03-T	-	-	Smooth bore XD interface, alignment plug, solder dipped
S008-L9X-04-T	-	-	Alignment plug, solder dipped
S012-T43-01	-	-	Full detent SI interface
S012-T45-01	-	-	Smooth bore XD interface
S012-T4X-02	-	-	

*Additional leg length, body styles, and packaging options for G4PO™ male straight to PCB connectors are available.

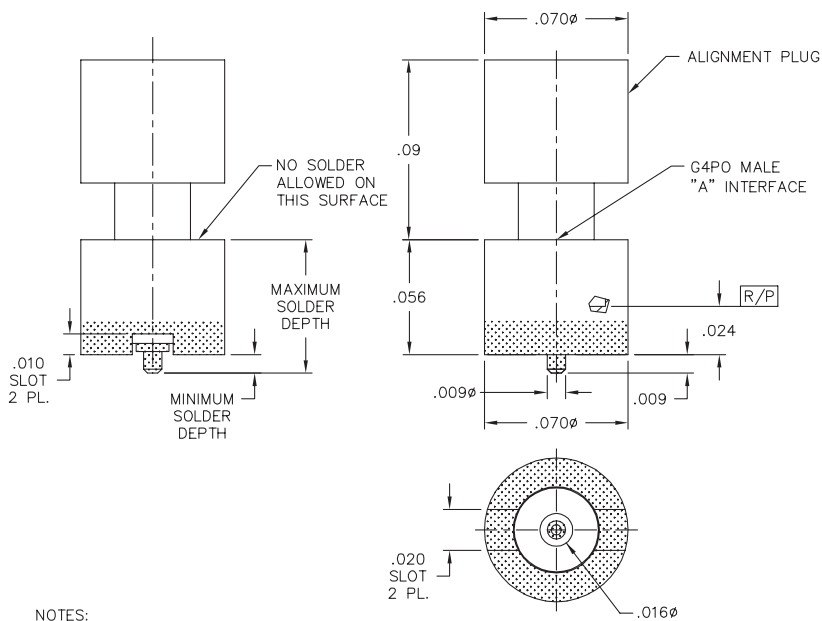

NOTES:
1. DIMENSIONS SHOWN BEFORE SOLDER DIP.

S008-L9X-04-T



S008-L9X-04-T

G4PO™ Vertical Launch PCB Mounts

Male Straight to PCB, Separate Center Conductor (C/C)

Catalog Number	Recommended Tools	Assembly Procedure	Notes
S012-T1X-01	-	-	Alignment plug

*Additional leg length, body styles, and packaging options for G4PO™ male straight to PCB connectors are available.

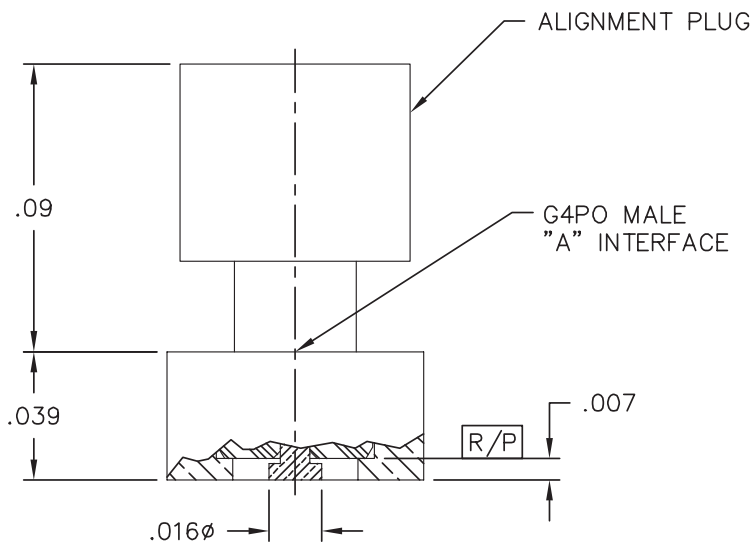

S012-T1X-01

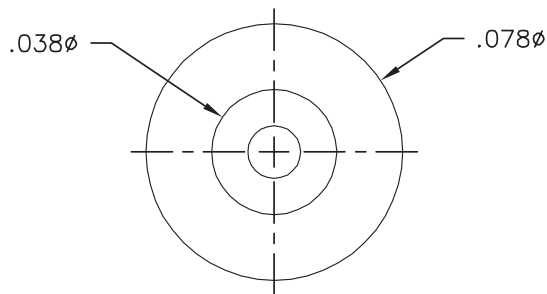

S012-T1X-01

G4PO™ Edge Mounts

Male Edge Flush Mount

Catalog Number	Recommended Tools	Assembly Procedure	Notes
S010-L1X-01	-	-	

*Additional body styles and packaging options for G4PO™ male edge-mount to PCB connectors are available.

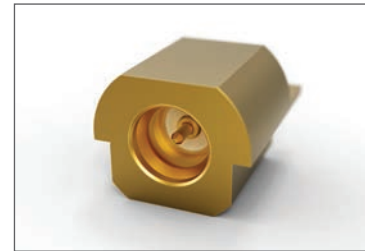
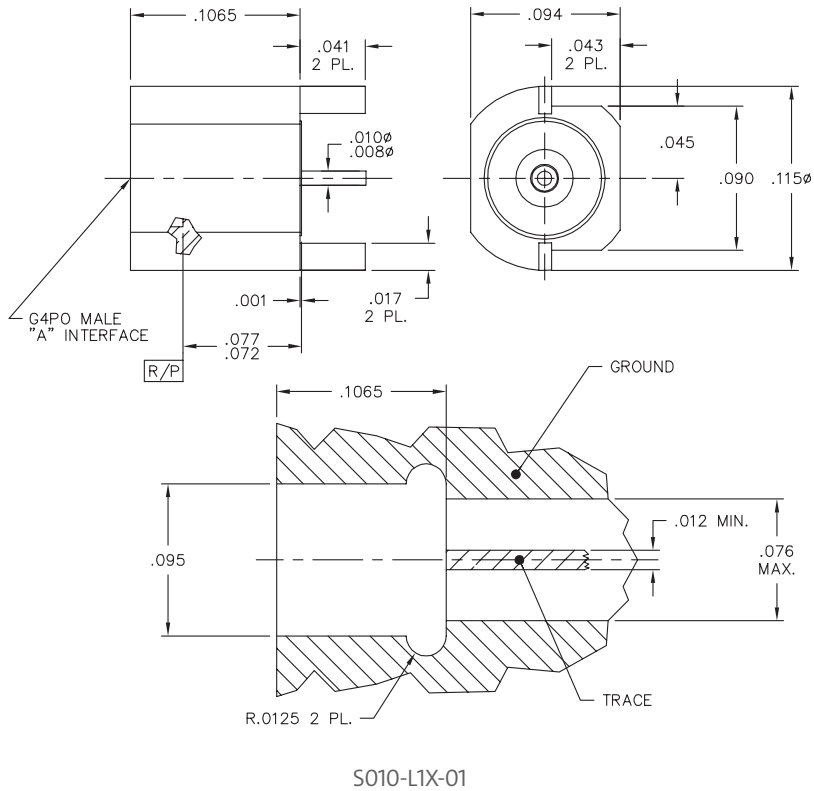

S010-L1X-01

G4PO™ Hermetic Shrouds

Male Hermetic Shroud (Solder-In)

Catalog Number	Recommended Tools	Assembly Procedure	Notes
S007-L4X-02-TAB-R	-	-	Pin lengths available from .025 to .075 in increments of .005

*Additional body styles and packaging options for G4PO™ shroud connectors are available.

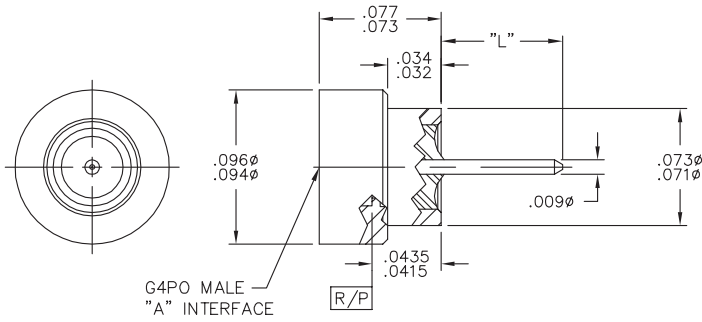

S007-L4X-02-TAB-R

RECOMMENDED
FLUSH SHROUD
MOUNTING HOLE

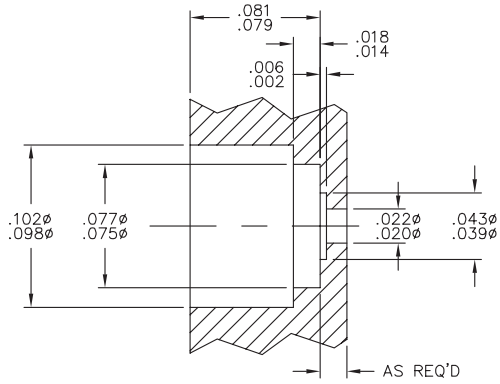

S007-L4X-02-TAB-R

G4PO™ Multiposition Blocks

Male Two-Position Block

Catalog Number	Recommended Tools	Assembly Procedure	Notes
S032-L4X-03-T	-	-	.070 interface pitch, solder dipped
S032-L4X-05-T	-	-	.070 interface pitch, solder dipped
S032-L93-01-T	-	-	G4PO SI full detent interface, .070 interface pitch, alignment plugs, solder dipped

*Additional body styles and packaging options for G4PO™ multiposition blocks are available.

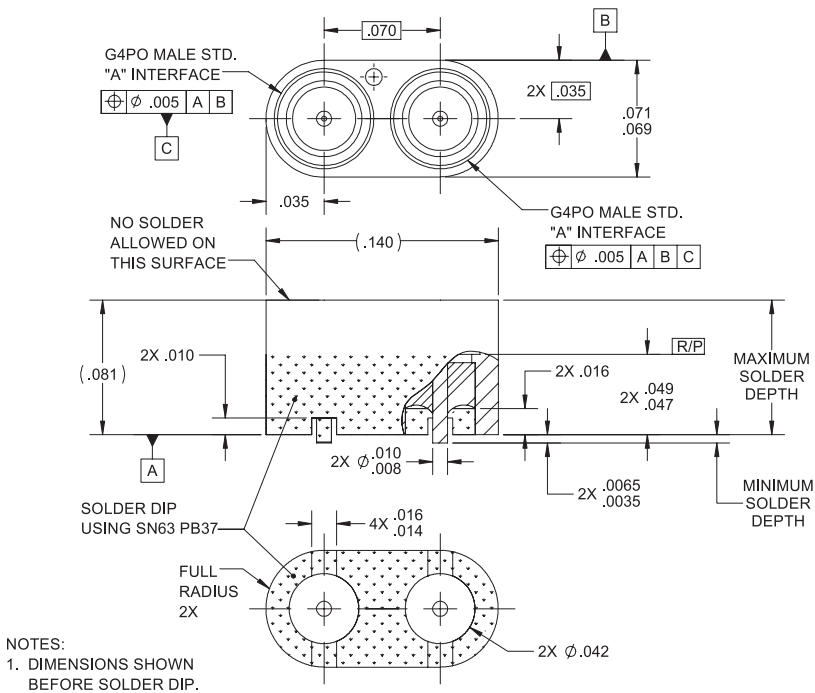

S032-L4X-05-T

S032-L4X-05-T

NOTES:
1. DIMENSIONS SHOWN BEFORE SOLDER DIP.

G4PO™ Multiposition Blocks

Male Three-Position Block

Catalog Number	Recommended Tools	Assembly Procedure	Notes
S036-T1X-01	-	-	.078 interface pitch, alignment plugs
S036-T1X-01@T13	-	-	.078 interface pitch, alignment plug, on tape and reel

*Additional body styles and packaging options for G4PO™ multiposition blocks are available.

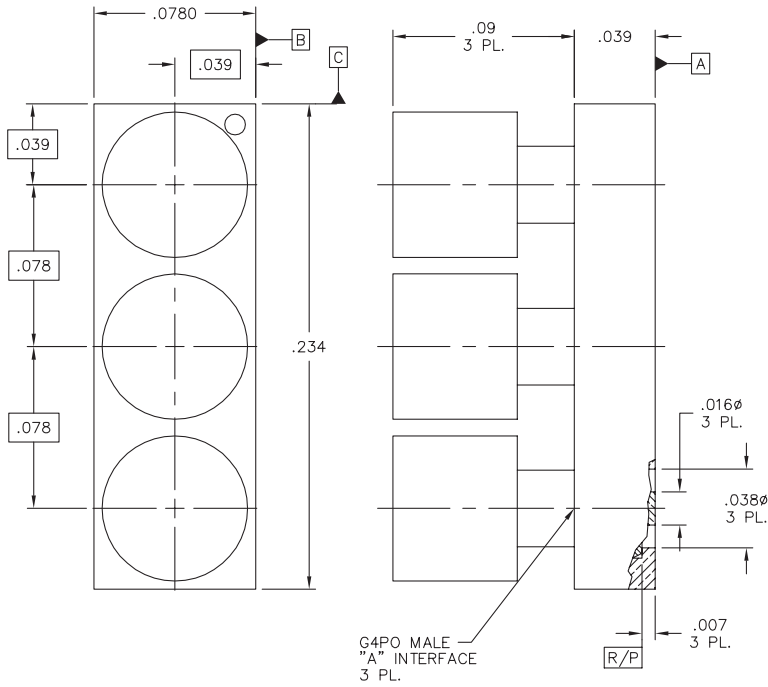

S036-T1X-01

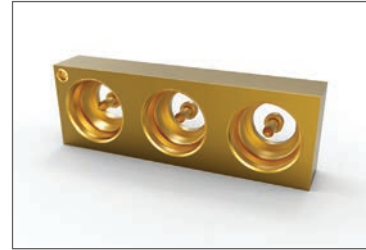

S036-T1X-01

G4PO™ Multiposition Blocks

Male Eight-Position Block

Catalog Number	Recommended Tools	Assembly Procedure	Notes
S036-T45-14	-	-	G4PO XD smooth bore interface, .067 interface pitch

*Additional body styles and packaging options for G4PO™ multiposition blocks are available.

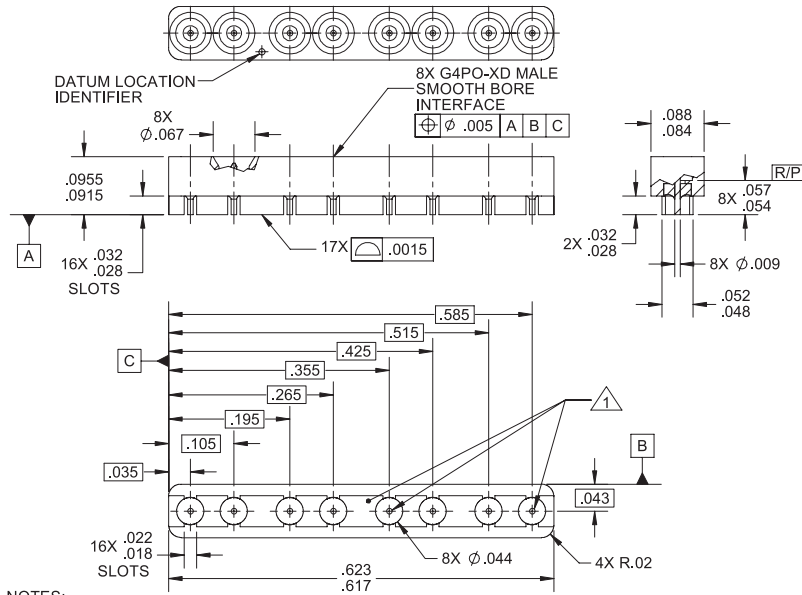

NOTES:

1. TARGET AREA FOR PLATING THICKNESS MEASUREMENT.

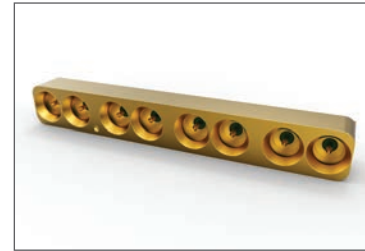

S036-T45-14

S036-T45-14

G4PO™ Accessories

Interface Plug (Alignment Plug)

Catalog Number	Recommended Tools	Assembly Procedure	Notes
Y072-A03-09	-	-	Full detent
Y072-A05-09	-	-	Smooth bore

*Additional body styles and packaging options for G4PO™ accessories are available.

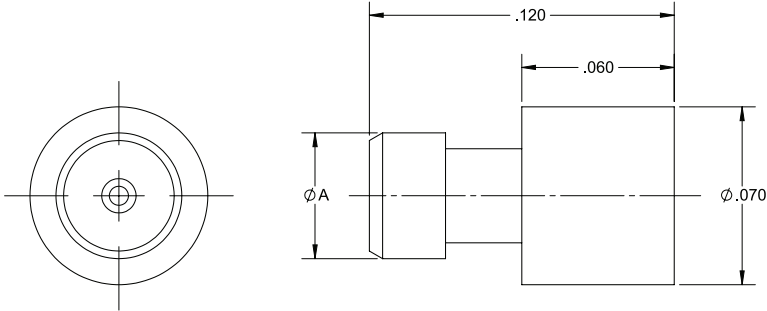

Y072-A03-09



Y072-A03-09



Cryogenic Products

- Nonmagnetic products, commonly used in cryogenic applications
- Variety of connectors available, across multiple Corning product families
- Designed to accommodate both radial and axial misalignment with negligible voltage standing wave ratio (VSWR) change

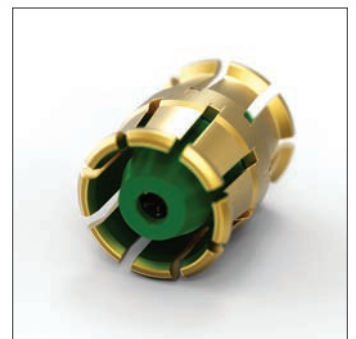

Cryogenic Specifications

General Characteristics

Impedance	See respective product families in previous sections for specifications.
Frequency range	
Temperature range	

Electrical Characteristics

VSWR	See respective product families in previous sections for specifications.
Insertion loss	
DWV @ sea level	
Insulation resistance	
Contact resistance	
Outer conductor	
Inner conductor	
RF leakage	

Mechanical Characteristics

Mate/demate cycles	See respective product families in previous sections for specifications.
Force to engage/disengage	
Tolerated misalignment	
Radial	
Axial	

Environmental Characteristics

Thermal shock	MIL-STD-202, Method 107, Condition B
Salt spray	MIL-STD-202, Method 101
Vibration	MIL-STD-202, Method 204
Shock	MIL-STD-202, Method 213, Condition I
Moisture resistance	MIL-STD-202, Method 106, except Step 7B

Materials (typical)

Bodies	Beryllium copper per ASTM B196 and or/ASTM B197
Outer contacts	Beryllium copper per ASTM B196 and or/ASTM B197
Center contacts	Beryllium copper per ASTM B196 and or/ASTM B197
Insulators	PTFE fluorocarbon per ASTM D1710

Finish (typical)

Bodies	Gold plated per MIL-G-45204, Type I, Grade C, Class 1, over copper flash
Contacts	Gold plated per MIL-G-45204, Type I, Grade C, Class 1, over copper flash

Cryogenic Blind Mate Interconnects

Female Blind Mate Interconnect (Bullet) – Standard

Catalog Number	Length (inches)	Recommended Tools	Assembly Procedure	Notes
B1B1-0009-02	.196	B095-A99-01	-	GPPO*
B1B1-0009-03	.210	B095-A99-01	-	GPPO
R1R1-0009-05-0098	.098	R098-A99-02	-	G3PO™
R1R1-0009-04-0188	.188	R098-A99-02	-	G3PO

*Additional lengths available upon request.

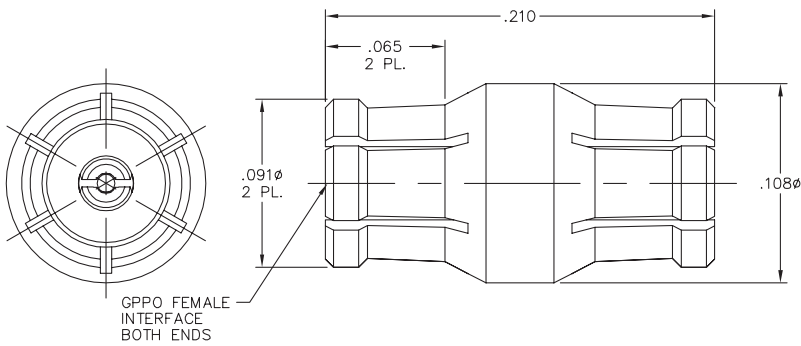

NOTES:

1. NONMAGNETIC PLATING, THIS CONNECTOR IS NOT TO BE USED IN STANDARD APPLICATIONS.



B1B1-0009-03

B1B1-0009-03

Cryogenic .047 Cable Connectors

Female Straight to .047 Semirigid (S/R) Cable

Catalog Number	Recommended Tools	Assembly Procedure	Notes
B014-B91-01	B096-A93-01, A096-A99-04, L096-A99-02, B098-A99-03	AP01-133	GPPO*
R014-B91-01	R096-A95-01, A096-A99-04, L096-A99-02, R098-A99-01	AP01-175	G3PO™
R014-B91-02	R096-A95-01, A096-A99-04, L096-A99-02, R098-A99-01	AP01-157	G3PO

*Semiflex cable can be substituted in place of .047 semirigid.

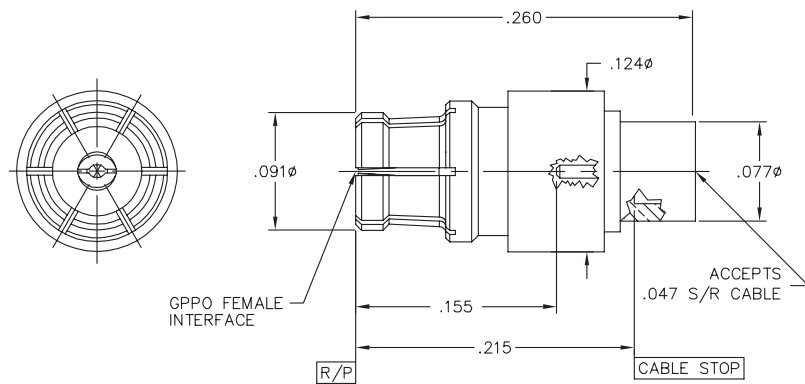

B014-B91-01

NOTES:

⚠️ NONMAGNETIC PLATING. THIS CONNECTOR IS NOT TO BE USED IN STANDARD APPLICATIONS.

B014-B91-01

Male Straight to .047 Semirigid (S/R) Cable

Catalog Number	Recommended Tools	Assembly Procedure	Notes
B014-B9X-02	B096-A99-01 (FD), B096-A99-02 (SB), L096-A99-02, B098-A99-05	AP01-094	GPPO
R014-B9X-01	R096-A23-01 (FD), R096-A25-01 (SB), A096-A99-04, L096-A99-02	AP01-158	G3PO

*Semiflex cable can be substituted in place of .047 semirigid.

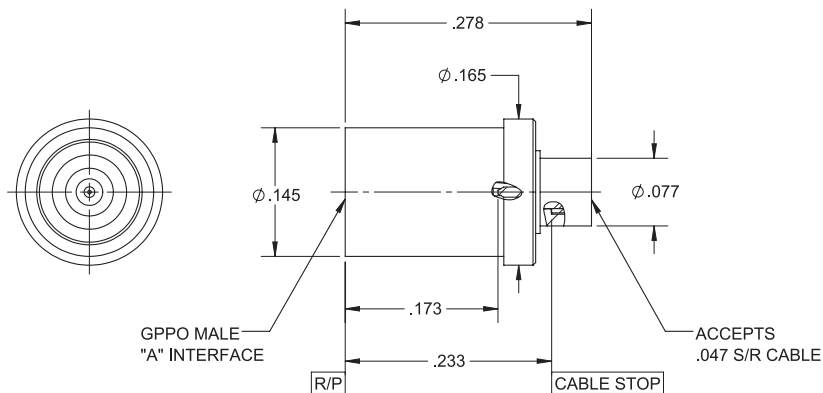

B014-B9X-02

B014-B9X-02

Cryogenic .047 Cable Connectors

Male Bulkhead to .047 Semirigid (S/R) Cable

Catalog Number	Recommended Tools	Assembly Procedure	Notes
B016-B9X-01	B096-A99-01 (FD), B096-A99-02 (SB), L096-A99-02, B097-A99-01	AP01-110	GPPO*

*Semiflex cable can be substituted in place of .047 semirigid.

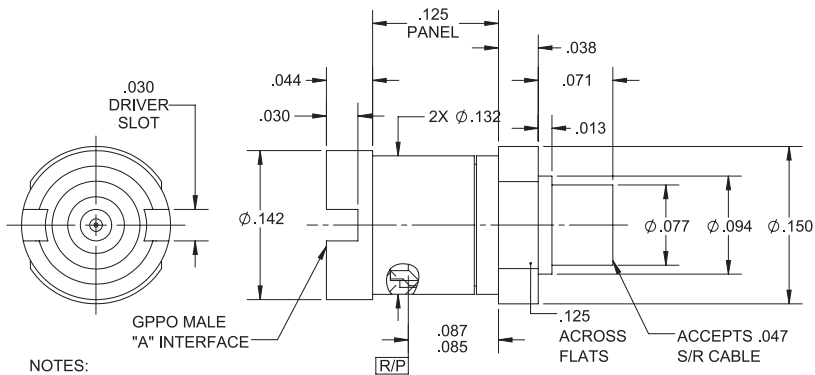

B016-B9X-01

1. NONMAGNETIC PLATING. THIS CONNECTOR IS NOT TO BE USED IN STANDARD APPLICATIONS.

B016-B9X-01

Female Snap-In to .047 Semirigid (S/R) Cable

Catalog Number	Recommended Tools	Assembly Procedure	Notes
B025-B91-01	B096-A93-01, A096-A99-09, L096-A99-02, 9001-824-0	AP01-103	GPPO, mates with SK-5889

*Semiflex cable can be substituted in place of .047 semirigid.

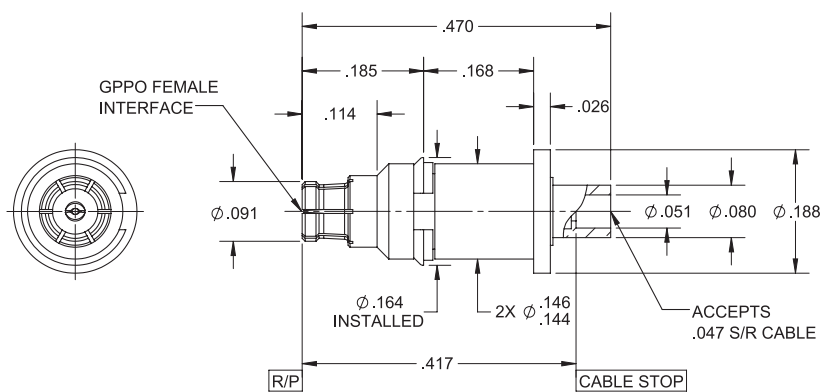

B025-B91-01

B025-B91-01

Cryogenic .047 Cable Connectors

Male Snap-In to .047 Semirigid (S/R) Cable

Catalog Number	Recommended Tools	Assembly Procedure	Notes
B014-B9X-03	B096-A99-01 (FD), B096-A99-02 (SB), L096-A99-02, B098-A99-05	AP01-094	GPPO*

*Semiflex cable can be substituted in place of .047 semirigid.

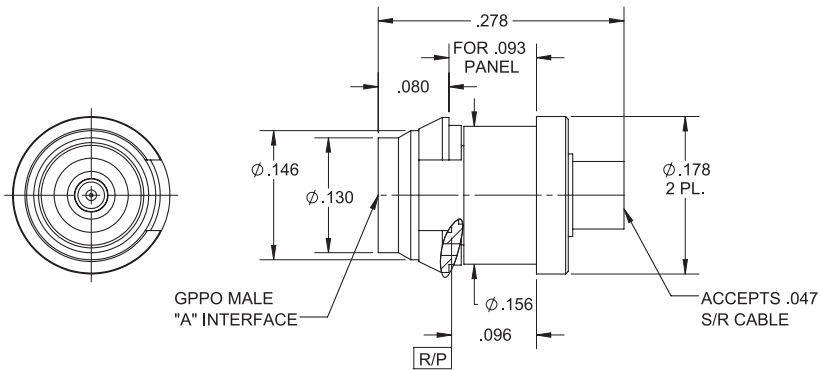

B014-B9X-03



B014-B9X-03

Cryogenic .086 Cable Connectors

Female Straight to .086 Semirigid (S/R) Cable

Catalog Number	Recommended Tools	Assembly Procedure	Notes
B014-D91-01	B096-A93-01, A096-A99-04, L096-A99-01, B098-A99-03	AP01-148	GPPO*

*Semiflex cable can be substituted in place of .086 semirigid.

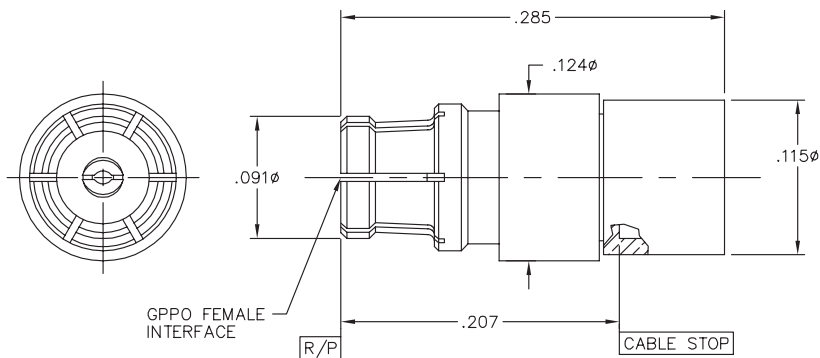

B014-D91-01



B014-D91-01

Male Straight to .086 Semirigid (S/R) Cable

Catalog Number	Recommended Tools	Assembly Procedure	Notes
B014-D9X-05	B096-A99-01 (FD), B096-A99-02 (SB), L096-A99-01	-	GPPO

*Semiflex cable can be substituted in place of .086 semirigid.

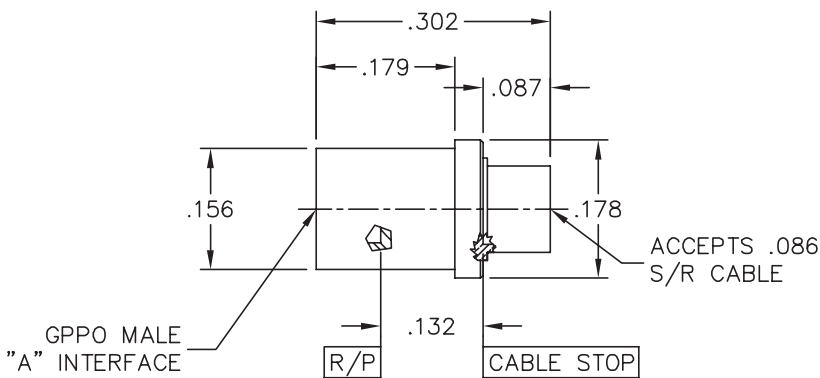

B014-D9X-05



B014-D9X-05

NOTE:
PART IS NONMAGNETIC. DO NOT UNDERPLATE WITH Ni. USE Cu.

Cryogenic .086 Cable Connectors

Female Right-Angle (R/A) to .086 Semirigid (S/R) Cable

Catalog Number	Recommended Tools	Assembly Procedure	Notes
B015-D91-01	B096-A93-01, A096-A99-10, L096-A99-01, B098-A99-07	AP01-112	GPPO*

*Semiflex cable can be substituted in place of .086 semirigid.

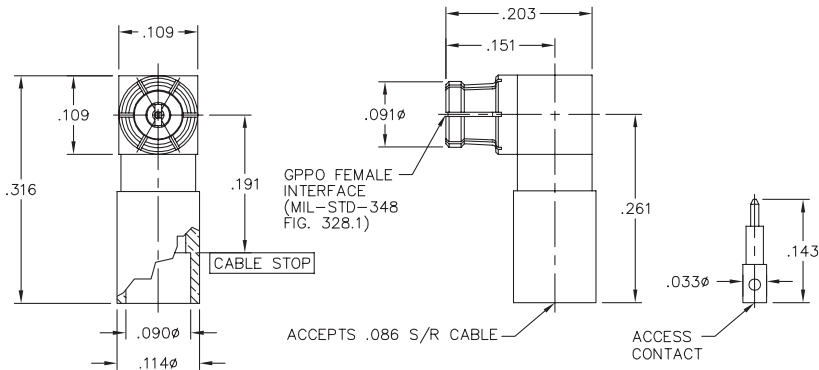

B015-D91-01

NOTE:
PART IS NONMAGNETIC. DO NOT UNDERPLATE WITH Ni. USE Cu.

B015-D91-01

Female Snap-In to .086 Semirigid (S/R) Cable

Catalog Number	Recommended Tools	Assembly Procedure	Notes
B025-D91-01	B096-A93-01, A096-A99-09, L096-A99-01, 9001-824-0	-	GPPO

*Semiflex cable can be substituted in place of .086 semirigid.

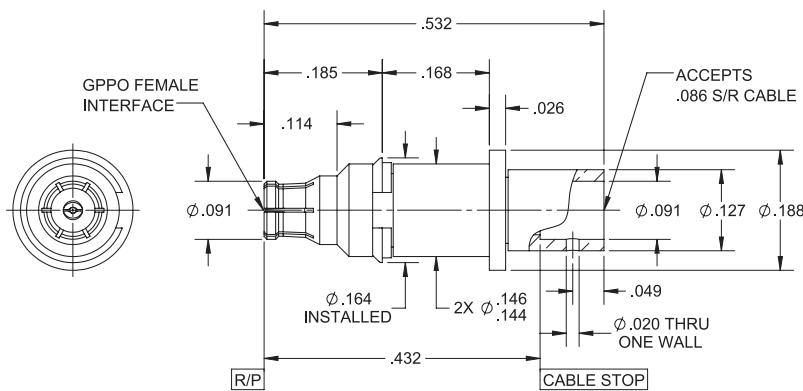

B025-D91-01

NOTES:
1. NONMAGNETIC PLATING. THIS CONNECTOR IS NOT TO BE USED IN STANDARD APPLICATIONS.
2. THIS CONNECTOR IS DESIGNED TO MATE WITH SK-5889.

B025-D91-01

Cryogenic .086 Cable Connectors

Male Snap-In to .086 Semirigid (S/R) Cable

Catalog Number	Recommended Tools	Assembly Procedure	Notes
B025-D9X-01	B096-A99-01, L096-A99-01	AP01-087	GPPO*

*Semiflex cable can be substituted in place of .086 semirigid.

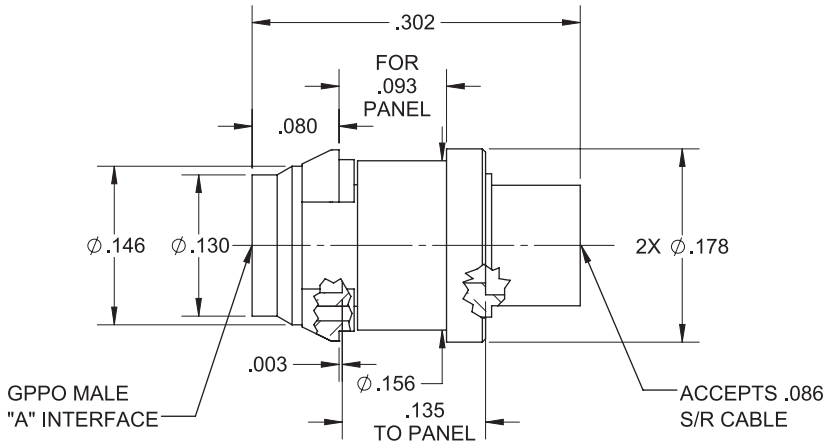

B025-D9X-01

NOTES:

- PART IS NONMAGNETIC. NOT TO BE USED IN STANDARD APPLICATIONS.

B025-D9X-01

Cryogenic Micro-Coax UT-085C-FORM-LL Cable Connectors

Male Bulkhead to Micro-Coax UT-085C-FORM-LL Cable

Catalog Number	Recommended Tools	Assembly Procedure	Notes
B016-K9X-01	B096-A99-01 (FD), B096-A99-02 (SB), L096-A99-01, B097-A99-01	AP01-111	GPPO*

*Semiflex cable can be substituted in place of .086 semirigid.

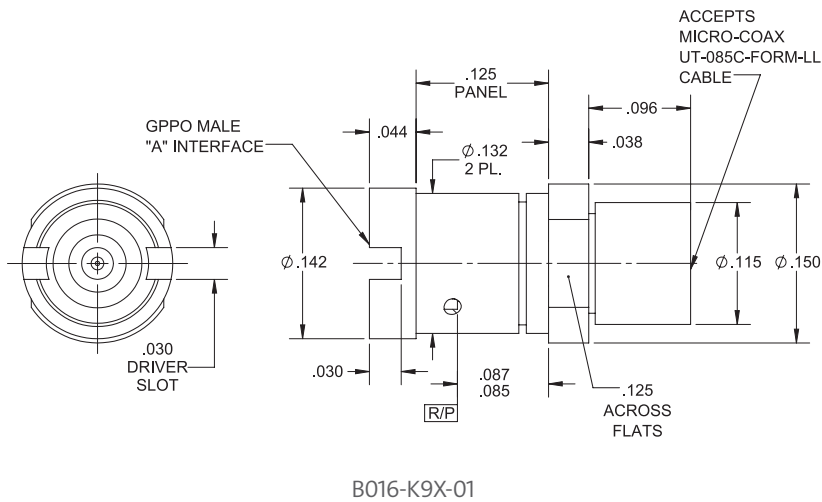

B016-K9X-01

Female Snap-In to Micro-Coax UT-085C-FORM-LL Cable

Catalog Number	Recommended Tools	Assembly Procedure	Notes
B025-K91-01	B096-A93-01, A096-A99-09, L096-A99-01, 9001-824-0	-	GPPO, mates with SK-5750

*Semiflex cable can be substituted in place of .086 semirigid.

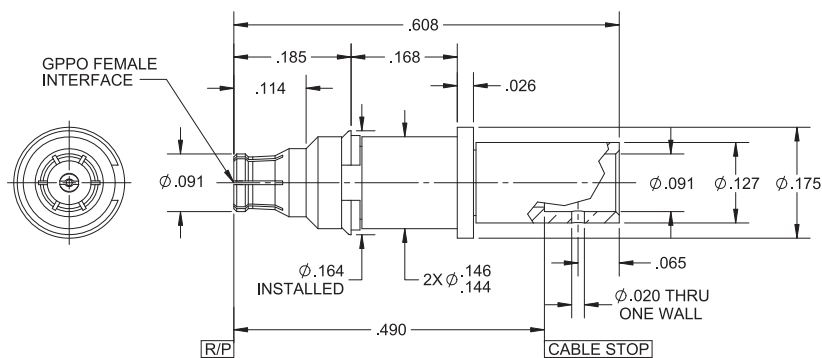

B025-K91-01

- NOTES:
1. NONMAGNETIC PLATING. THIS CONNECTOR IS NOT TO BE USED IN STANDARD APPLICATIONS.
 2. THIS CONNECTOR IS DESIGNED TO MATE WITH SK-5750.

B025-K91-01

Cryogenic Vertical-Launch PCB Mounts

Male Straight to PCB, Round Body

Catalog Number	Recommended Tools	Assembly Procedure	Notes
B012-L9X-04-T	-	-	GPPO®, solder dipped
B012-L9X-05-T	-	-	GPPO, solder dipped
R008-L95-01	-	-	G3PO™-SI smooth bore interface
R008-L95-01-T	-	-	G3PO-SI smooth bore interface, solder dipped

*Additional leg length, body styles, and packaging options for cryogenic male straight to PCB connectors are available.

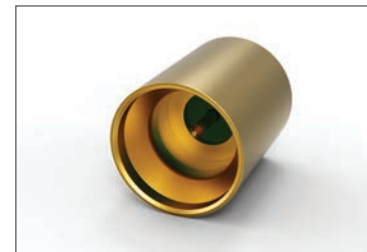
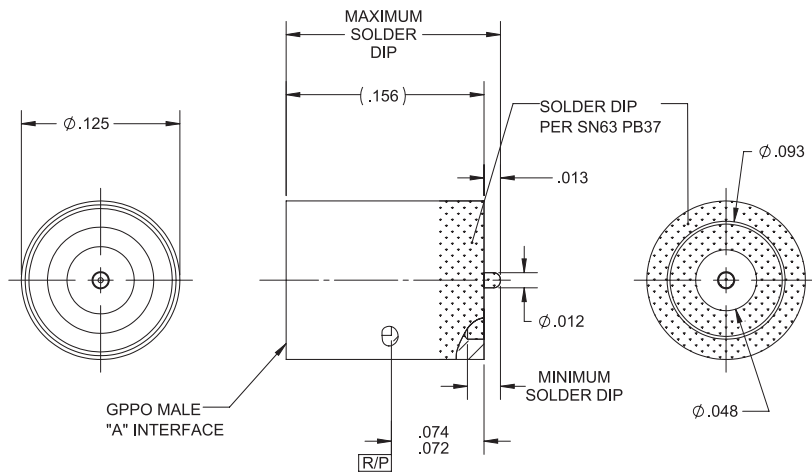

B012-L9X-04-T

NOTES:

1. NONMAGNETIC PLATING. THIS CONNECTOR IS NOT TO BE USED IN STANDARD APPLICATIONS.
2. ALL DIMENSIONS APPLY BEFORE SOLDER DIP.

B012-L9X-04-T

Cryogenic Edge Mounts

Male Edge Mount, Standard

Catalog Number	Recommended Tools	Assembly Procedure	Notes
R010-L9X-02	-	-	G3PO™

*Additional body styles and packaging options for cryogenic male edge-mount to PCB connectors are available.

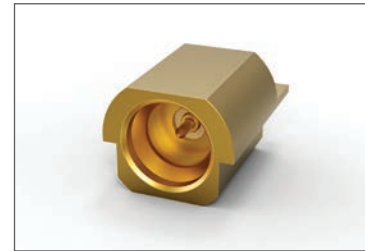
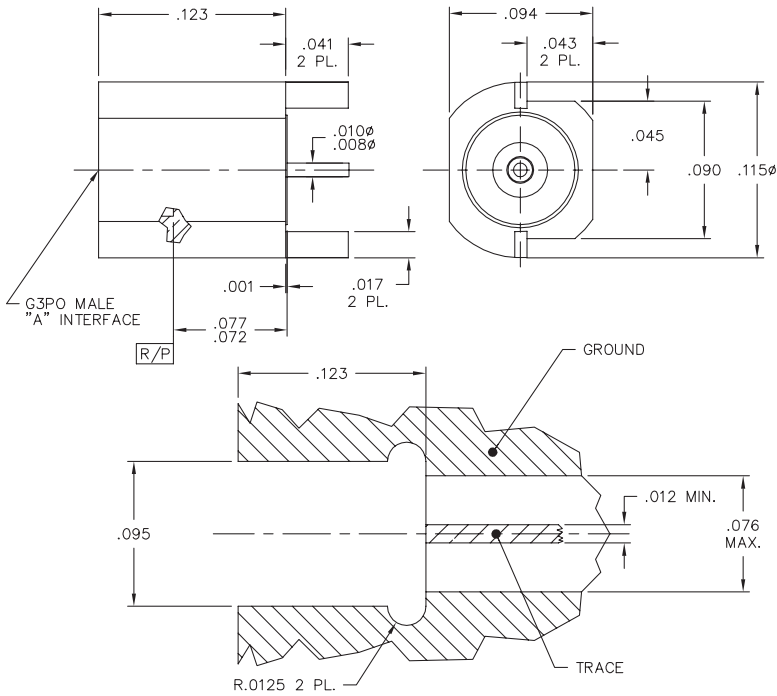

R010-L9X-02

NOTE:
PART IS NONMAGNETIC. DO NOT UNDERPLATE WITH Ni. USE Cu.

R010-L9X-02

Male Edge Mount, Non-Standard

Catalog Number	Recommended Tools	Assembly Procedure	Notes
R010-L95-01	-	-	G3PO smooth bore

*Additional body styles and packaging options for cryogenic male edge-mount to PCB connectors are available.

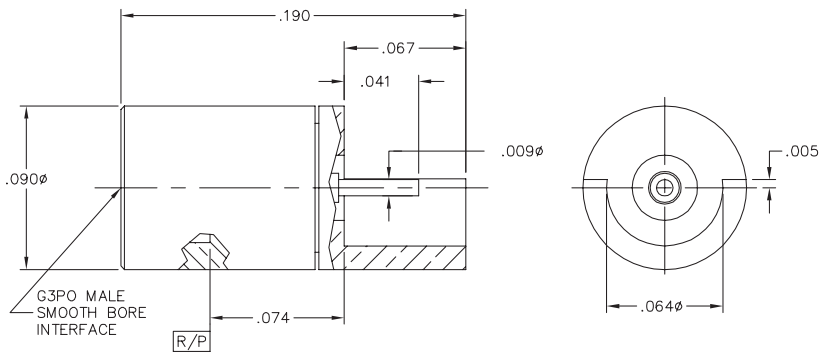

R010-L95-01

R010-L95-01

Cryogenic Solder-In Shrouds

Male Solder-In Shroud

Catalog Number	Recommended Tools	Assembly Procedure	Notes
B026-L9X-01	B096-A99-01 (FD), B096-A99-02 (SB)	-	

*Additional body styles and packaging options for cryogenic shroud connectors are available.

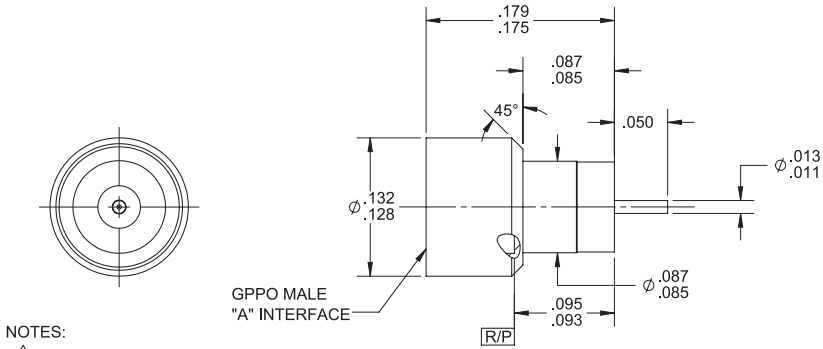

B026-L9X-01

NOTES:
 1. NONMAGNETIC PLATING. THIS CONNECTOR IS NOT TO BE USED IN STANDARD APPLICATIONS.

B026-L9X-01

Cryogenic Multiposition Blocks

Eight-Position Block

Catalog Number	Recommended Tools	Assembly Procedure	Notes
B032-L94-07	-	-	GPPO*

*Additional body styles and packaging options for cryogenic multiposition blocks are available.

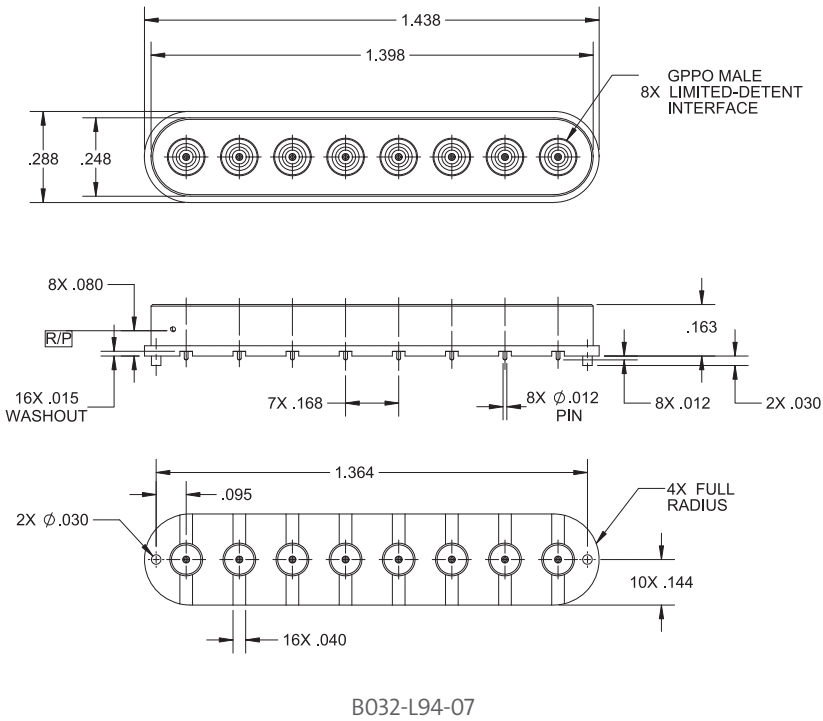

B032-L94-07

Cryogenic Accessories

Female Short

Catalog Number	Recommended Tools	Assembly Procedure	Notes
B055-A91-01	B098-A99-03	-	GPPO*

*Additional body styles and packaging options for cryogenic accessories are available.

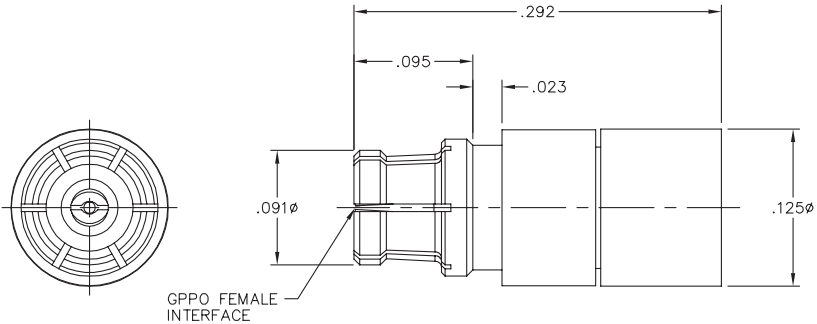

B055-A91-01

NOTES:
 ⚠️ NONMAGNETIC PLATING. THIS SHORT IS NOT TO BE USED IN STANDARD APPLICATIONS.

B055-A91-01



MIL-C-38999 Products

- Outer package designed to meet 38999 MIL specifications
- Variety of connectors available, across multiple Corning product families
- Designed to accommodate both radial and axial misalignment with negligible voltage standing wave ratio (VSWR) change

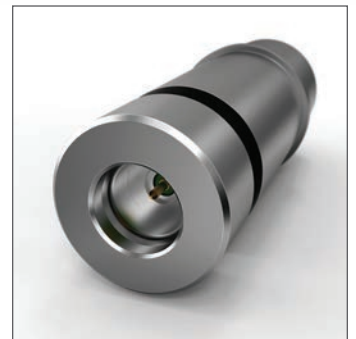

38999 Specifications

General Characteristics

Impedance	See respective product families in previous sections for specifications.
Frequency range	
Temperature range	

Electrical Characteristics

VSWR	See respective product families in previous sections for specifications.
Insertion loss	
DWV @ sea level	
Insulation resistance	
Contact resistance	
Outer conductor	
Inner conductor	
RF leakage	

Mechanical Characteristics

Mate/demate cycles	See respective product families in previous sections for specifications.
Force to engage/disengage	
Tolerated misalignment	
Radial	
Axial	

Environmental Characteristics

Thermal shock	MIL-STD-202, Method 107, Condition B
Salt spray	MIL-STD-202, Method 101
Vibration	MIL-STD-202, Method 204
Shock	MIL-STD-202, Method 213, Condition I
Moisture resistance	MIL-STD-202, Method 106, except Step 7B

Materials (typical)

Bodies	Beryllium copper per ASTM B196 and or/ASTM B197
Outer contacts	Beryllium copper per ASTM B196 and or/ASTM B197
Center contacts	Beryllium copper per ASTM B196 and or/ASTM B197
Insulators	PTFE fluorocarbon per ASTM D1710

Finish (typical)

Bodies	Gold plated per MIL-G-45204, Type I, Grade C, Class 1, over nickel plate per SAE AMS-QQ-N-290
Contacts	Gold plated per MIL-G-45204, Type I, Grade C, Class 1, over nickel plate per SAE AMS-QQ-N-290

MIL-C-38999 .047 Cable Connectors

Size No. 10 GPO® to .047 Flex Cable

Catalog Number	Recommended Tools	Assembly Procedure	Notes
A014-B11-03	-	-	GPO® female
A014-B95-01	-	-	GPO male

*Additional cable options for size no. 10 GPO 38999 connectors are available.

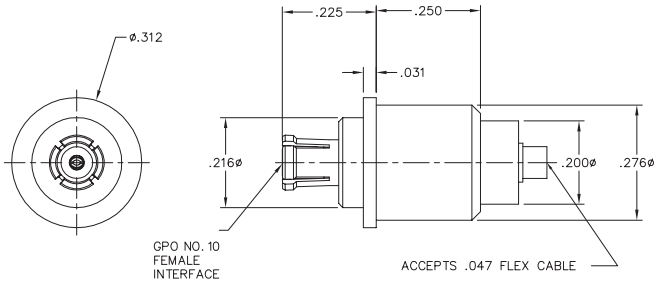

A014-B11-03

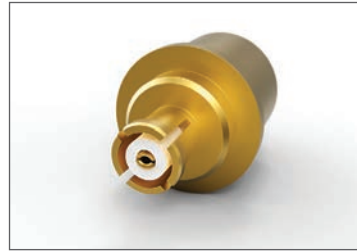

A014-B11-03

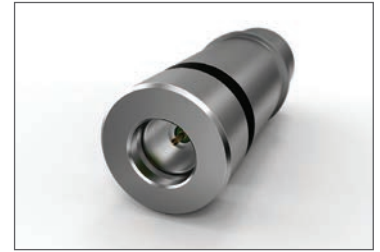

A014-B95-01

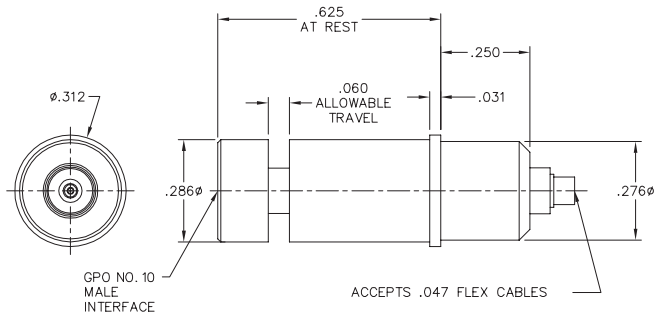

A014-B95-01

MIL-C-38999 .047 Cable Connectors

Size No. 12 GPPO® to .047 Flex Cable

Catalog Number	Recommended Tools	Assembly Procedure	Notes
B014-B11-02	-	-	GPPO® female
B014-B95-01	-	-	GPPO male

*Additional cable options for size no. 12 GPPO 38999 connectors are available.

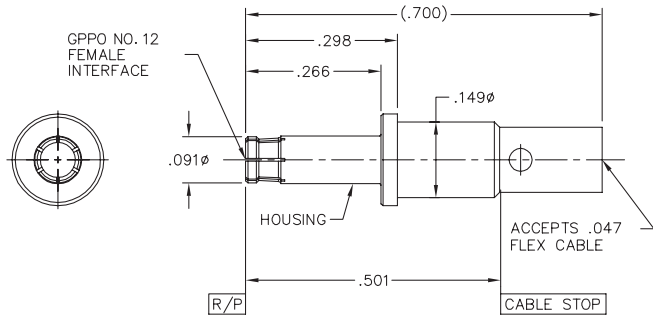

B014-B11-02



B014-B11-02



B014-B95-01

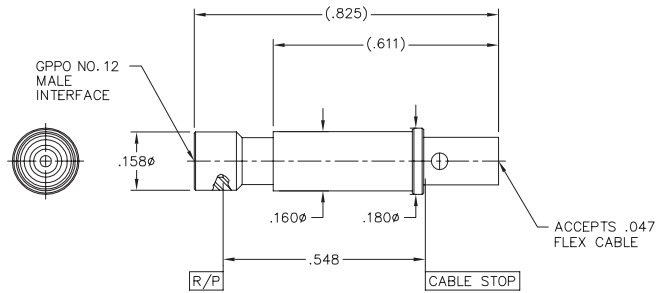

B014-B95-01

MIL-C-38999 .086 Cable Connectors

Size No. 10 GPO® to .086 Flex Cable

Catalog Number	Recommended Tools	Assembly Procedure	Notes
A014-D11-05	-	-	GPO® female
A014-D95-01	-	-	GPO male

*Additional cable options for size no. 10 GPO 38999 connectors are available.

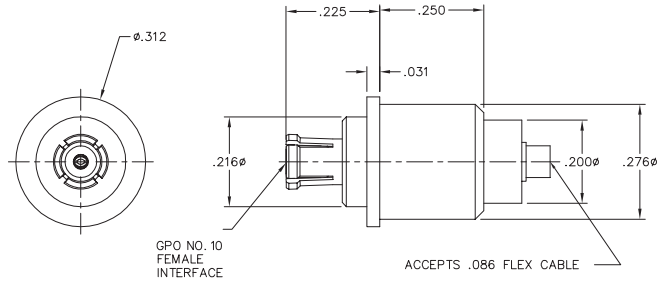

A014-D11-05



A014-D11-05



A014-D95-01

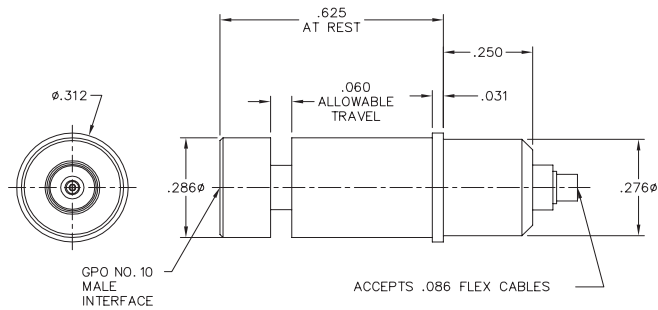

A014-D95-01

MIL-C-38999 .086 Cable Connectors

Size No. 12 GPPO® to .086 Flex Cable

Catalog Number	Recommended Tools	Assembly Procedure	Notes
B014-D11-02	-	-	GPPO® female
B014-D95-01	-	-	GPPO male

*Additional cable options for size no. 12 GPPO 38999 connectors are available.

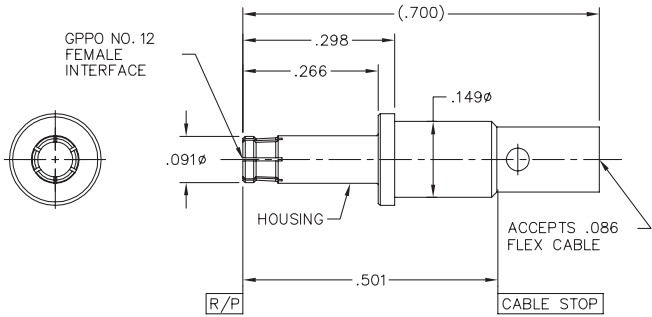

B014-D11-02



B014-D11-02



B014-D95-01

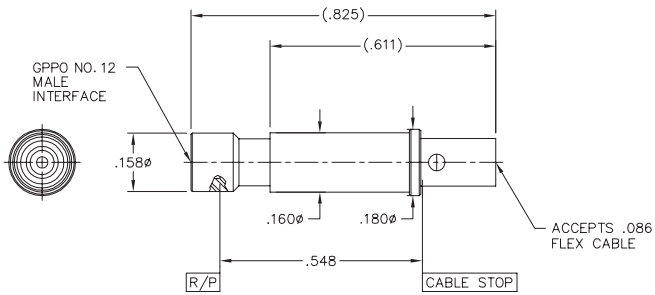

B014-D95-01

MIL-C-38999 RG-316 Cable Connectors

Size No. 10 GPO® to RG-316 Flex Cable

Catalog Number	Recommended Tools	Assembly Procedure	Notes
A014-F11-03	-	-	GPO® female
A014-F95-01	-	-	GPO male

*Additional cable options for size no. 10 GPO 38999 connectors are available.

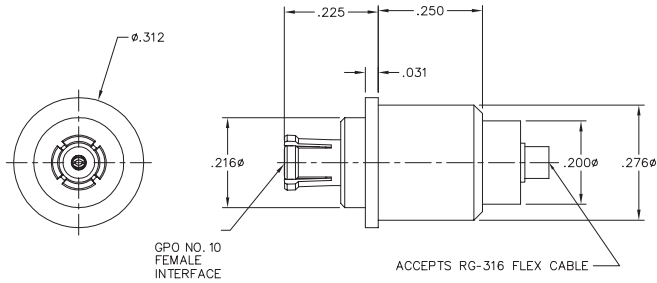

A014-F11-03

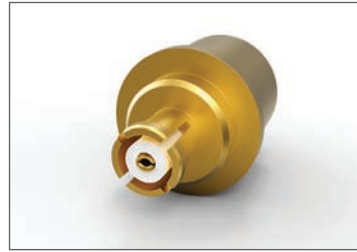

A014-F11-03



A014-F95-01

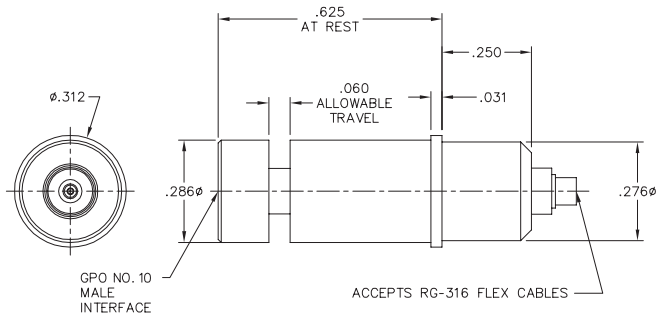

A014-F95-01

MIL-C-38999 RG-316 Cable Connectors

Size No. 12 GPPO® to RG-316 Flex Cable

Catalog Number	Recommended Tools	Assembly Procedure	Notes
B014-F11-01	-	-	GPPO® female
B014-F95-01	-	-	GPPO male

*Additional cable options for size no. 12 GPPO 38999 connectors are available.

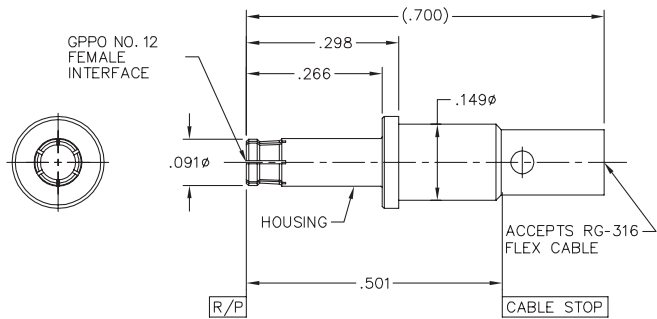

B014-F11-01



B014-F11-01



B014-F95-01

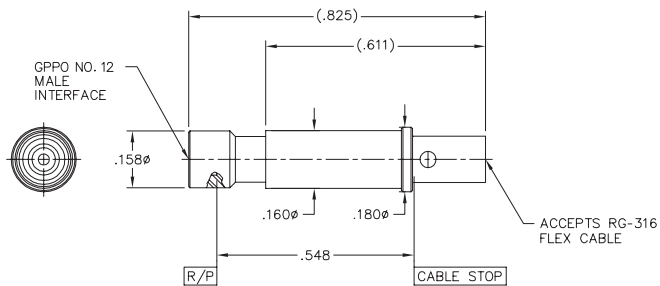

B014-F95-01



Adapters



Adapter Matrix

The chart listed below is designed to aid in locating the appropriate adapter by application. All adapters can be found in this catalog.

GPO® (female)

2.4 mm (jack)	1A1C1-0521-01
2.4 mm (plug)	1A1C2-0521-01
2.92 mm (jack)	1A1D1-0501-01
2.92 mm (plug)	1A1D2-0501-01
SMA (jack)	1A1F1-0503-01
SMA (plug)	1A1F2-0503-01
GPO® (female)	GPO bullets
GPO (male)	A1AX-0503-01
GPPO® (female)	1B1A1-0501-02

GPO (male)

2.4 mm (jack)	1AXC1-0503-01
2.4 mm (plug)	1AXC2-0503-01
2.92 mm (jack)	1AXD1-0503-01
2.92 mm (plug)	1AXD2-0503-01
SMA (jack)	1AXF1-0503-01
SMA (plug)	1AXF2-0503-01
GPO (male)	AXAX-0523-03

GPPO® (female)

1.85 mm (jack)	1B1M1-0509-01
1.85 mm (plug)	1B1M2-0509-01
2.4 mm (jack)	1B1C1-0501-01
2.4 mm (plug)	1B1C2-0501-01
2.92 mm (jack)	1B1D1-0503-01
SMA (jack)	1B1F1-0503-01
SMA (plug)	1B1F2-0503-01
GPO (female)	1B1A1-1509-01
GPO (male)	1B1A3-0541-01
GPPO® (female)	GPPO bullets

GPPO (male)

1.85 mm (jack)	1BXM1-0509-01
1.85 mm (plug)	1BXM2-0509-01
2.4 mm (jack)	1BXC1-0503-01
2.4 mm (plug)	1BXC2-0503-01
2.92 mm (jack)	1BXD1-0503-01
2.92 mm (plug)	1BXD2-0503-01
SMA (jack)	1BXF1-0503-01
SMA (plug)	1BXF2-0503-01
GPPO (male)	BXBX-0523-02

G3PO™ (female)

1.85 mm (jack)	1R1M1-0509-01
1.85 mm (plug)	1R1M2-0509-01
2.4 mm (jack)	1R1C1-0501-01
2.92 mm (jack)	1R1D1-0503-01
SMA (jack)	1R1F1-0503-01
G3PO™ (female)	G3PO bullets

G3PO (male)

1.85 mm (jack)	1RXM1-0503-01
1.85 mm (plug)	1RXM2-0503-01
2.4 mm (jack)	1RXC1-0503-01
2.92 mm (jack)	1RXD1-0503-01
2.92 mm (plug)	1RXD2-0503-01
SMA (jack)	1RXF1-0509-01
SMA (plug)	1RXF2-0503-01
G3PO (female)	R1R5-0501-01

G4PO™ (female)

G4PO™ (female)	G4PO bullets
----------------	--------------

G4PO (male)

1.85 mm (jack)	1SXM1-0503-01
2.92 mm (plug)	1SXD2-0503-01

*Note: The X listed in part numbers refers to a tabulated detent. Replace the X with 3 for full detent, 4 for limited detent (when available), or 5 for smooth bore.

† Male = plug, female = jack

‡ 1.85 mm adapters supersede 2.4 mm adapters with better performance.

§ 2.92 mm adapters supersede 3.5 mm and SMA adapters with better performance.

GPO® Female Adapters

GPO® Female to 2.4 mm Jack Adapter

Catalog Number	Recommended Tools	Assembly Procedure	Notes
1A1C1-0521-01	-	-	

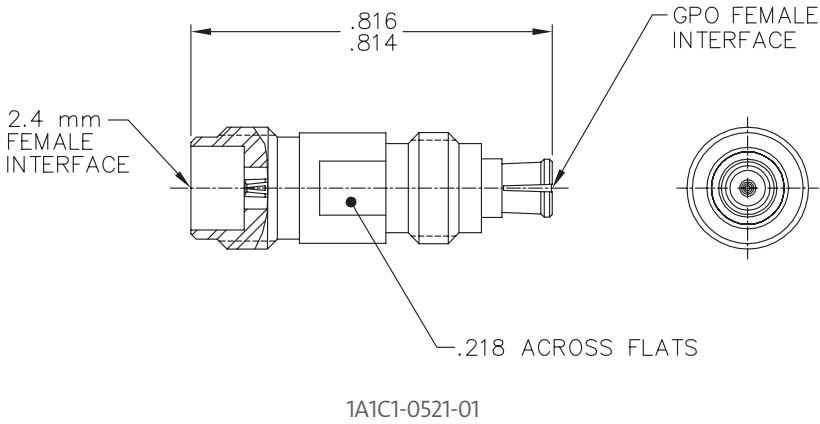

1A1C1-0521-01

GPO Female to 2.4 mm Plug Adapter

Catalog Number	Recommended Tools	Assembly Procedure	Notes
1A1C2-0521-01	-	-	

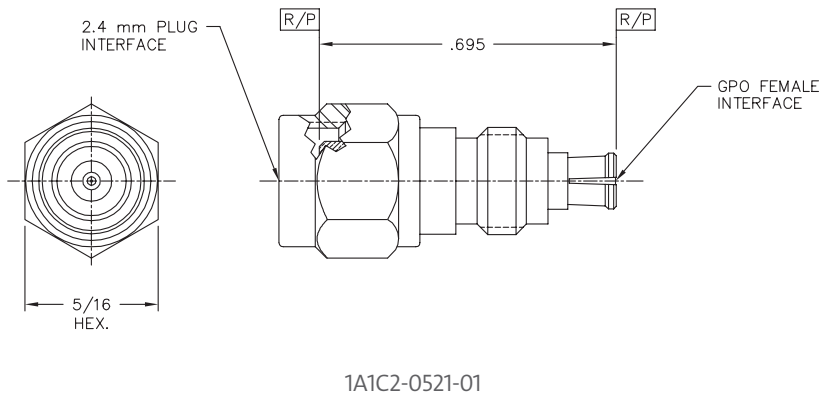

1A1C2-0521-01

GPO® Female Adapters

GPO® Female to 2.92 mm Jack Adapter

Catalog Number	Recommended Tools	Assembly Procedure	Notes
1A1D1-0501-01	-	-	

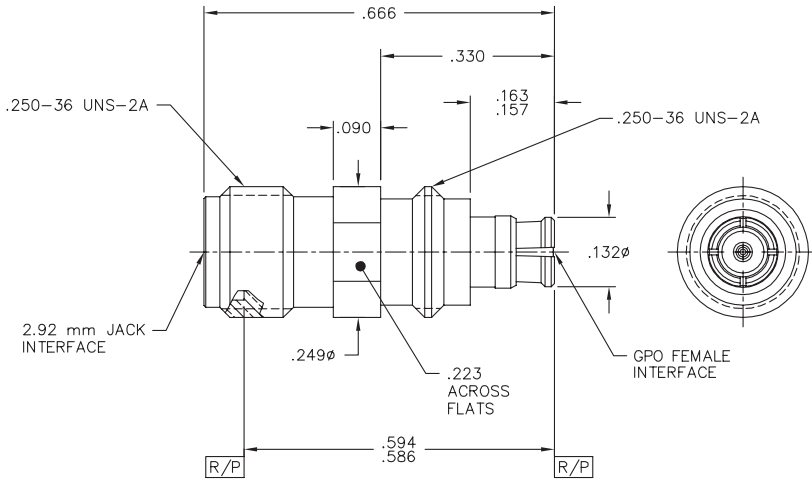

1A1D1-0501-01



1A1D1-0501-01

GPO Female to 2.92 mm Plug Adapter

Catalog Number	Recommended Tools	Assembly Procedure	Notes
1A1D2-0501-01	-	-	

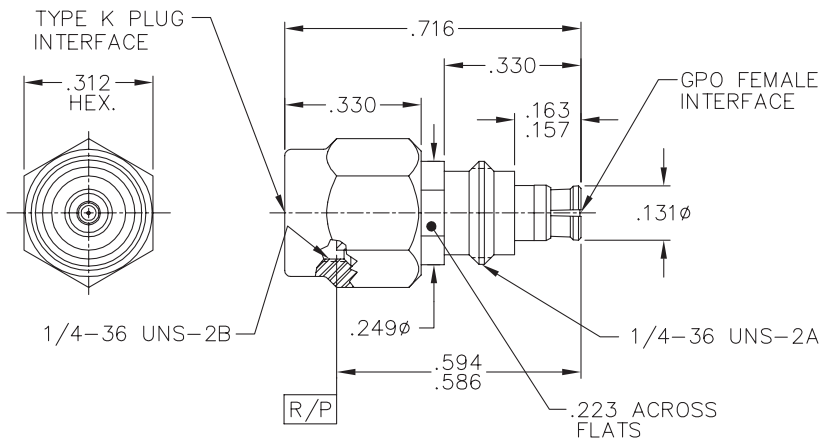

1A1D2-0501-01

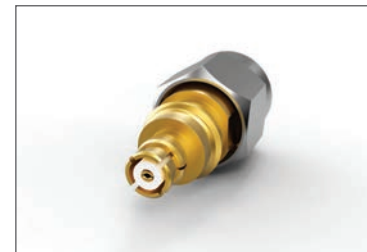

1A1D2-0501-01

GPO® Female Adapters

GPO® Female to SMA Jack Adapter

Catalog Number	Recommended Tools	Assembly Procedure	Notes
1A1F1-0503-01	-	-	

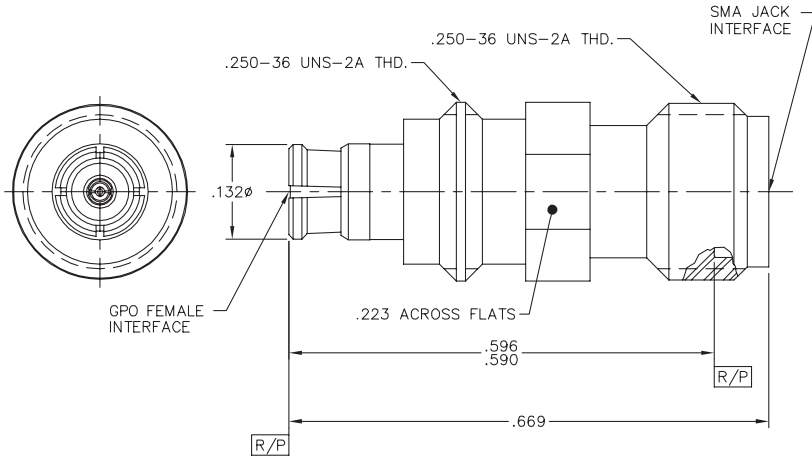

1A1F1-0503-01



1A1F1-0503-01

GPO Female to SMA Plug Adapter

Catalog Number	Recommended Tools	Assembly Procedure	Notes
1A1F2-0503-01	-	-	

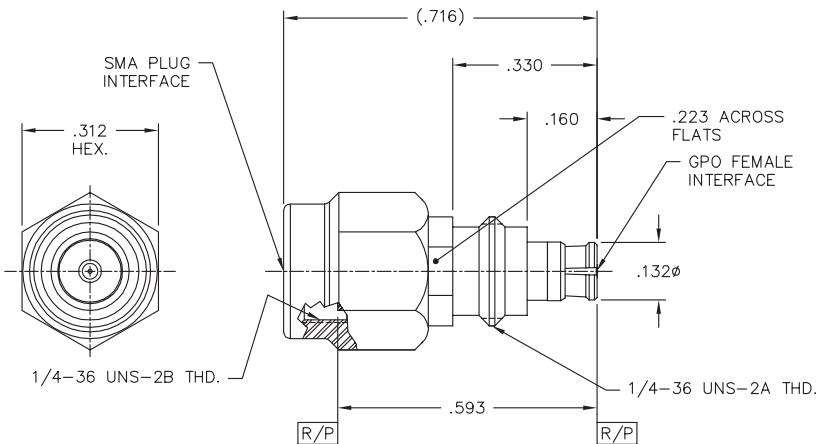

1A1F2-0503-01



1A1F2-0503-01

GPO® Female Adapters

GPO® Female to GPO Male Adapter

Catalog Number	Recommended Tools	Assembly Procedure	Notes
A1AX-0503-01	-	-	

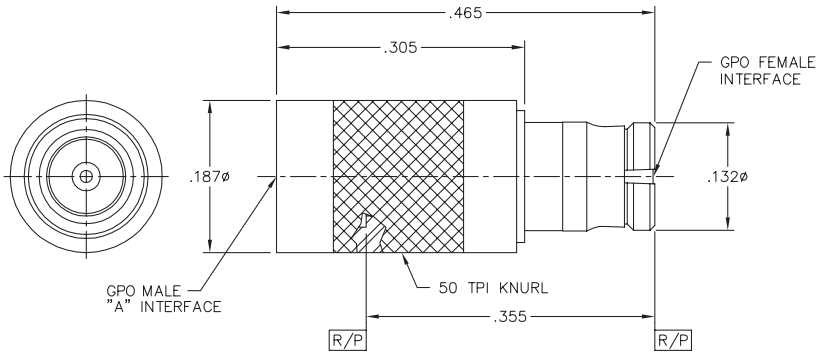

A1AX-0503-01



A1AX-0503-01

GPO Female to GPPO® Female Adapter

Catalog Number	Recommended Tools	Assembly Procedure	Notes
1B1A1-0501-02	-	-	

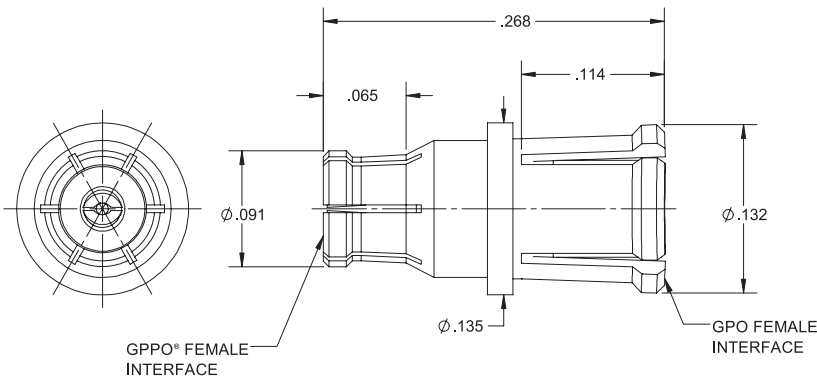

1B1A1-0501-02



1B1A1-0501-02

GPO® Male Adapters

GPO® Male to 2.4 mm Jack Adapter

Catalog Number	Recommended Tools	Assembly Procedure	Notes
1AXC1-0503-01	-	-	

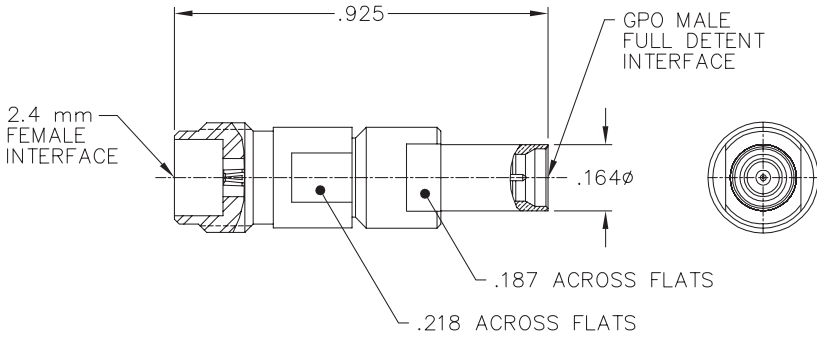

1AXC1-0503-01



1AXC1-0503-01

GPO Male to 2.4 mm Plug Adapter

Catalog Number	Recommended Tools	Assembly Procedure	Notes
1AXC2-0503-01	-	-	

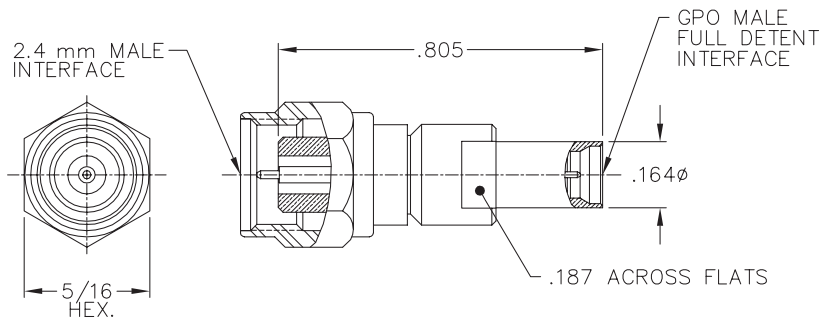

1AXC2-0503-01



1AXC2-0503-01

GPO® Male Adapters

GPO® Male to 2.92 mm Jack Adapter

Catalog Number	Recommended Tools	Assembly Procedure	Notes
1AXD1-0503-01	-	-	

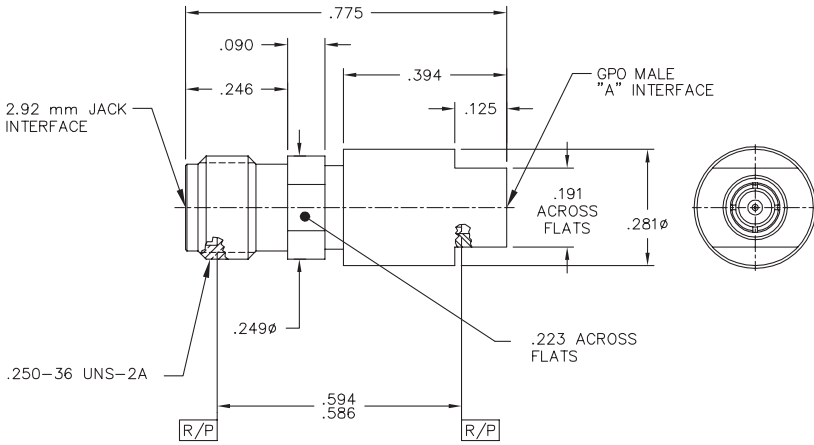

1AXD1-0503-01



1AXD1-0503-01

GPO Male to 2.92 mm Plug Adapter

Catalog Number	Recommended Tools	Assembly Procedure	Notes
1AXD2-0503-01	-	-	

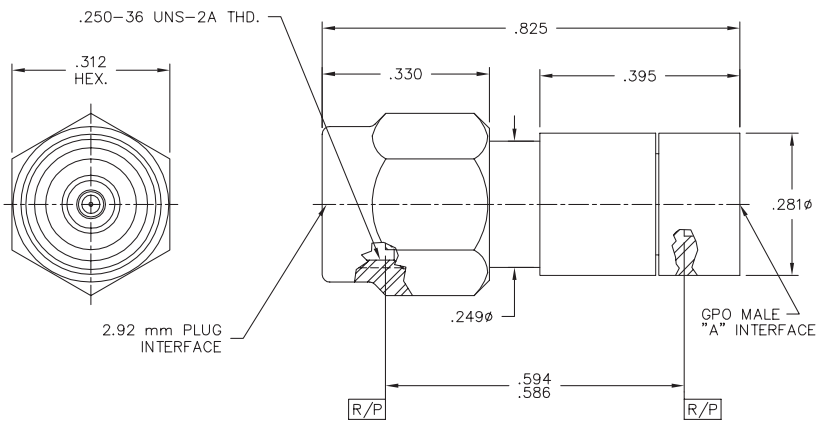

1AXD2-0503-01



1AXD2-0503-01

GPO® Male Adapters

GPO® Male to SMA Jack Adapter

Catalog Number	Recommended Tools	Assembly Procedure	Notes
1AXF1-0503-01	-	-	

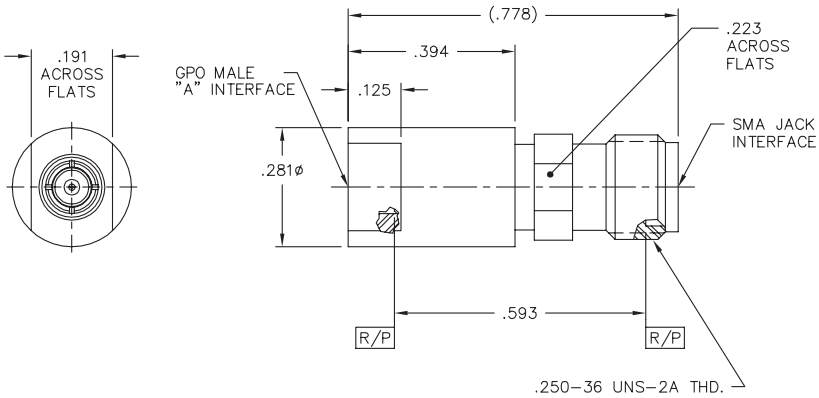

1AXF1-0503-01



1AXF1-0503-01

GPO Male to SMA Plug Adapter

Catalog Number	Recommended Tools	Assembly Procedure	Notes
1AXF2-0503-01	-	-	

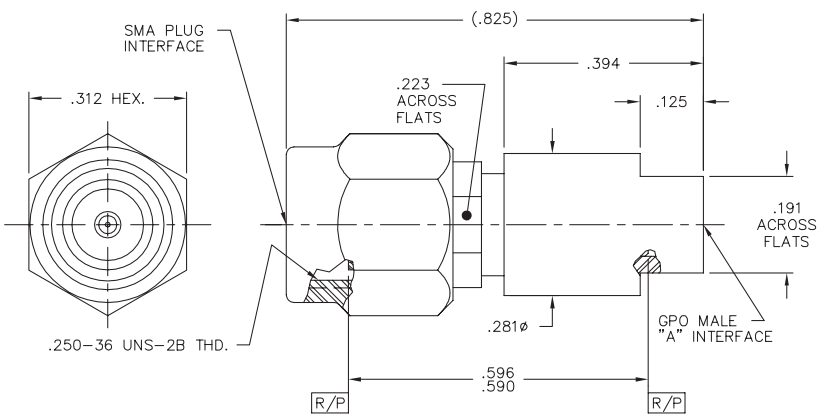

1AXF2-0503-01



1AXF2-0503-01

GPO® Male Adapters

GPO® Male to GPO Male Adapter

Catalog Number	Recommended Tools	Assembly Procedure	Notes
AXAX-0523-03	-	-	

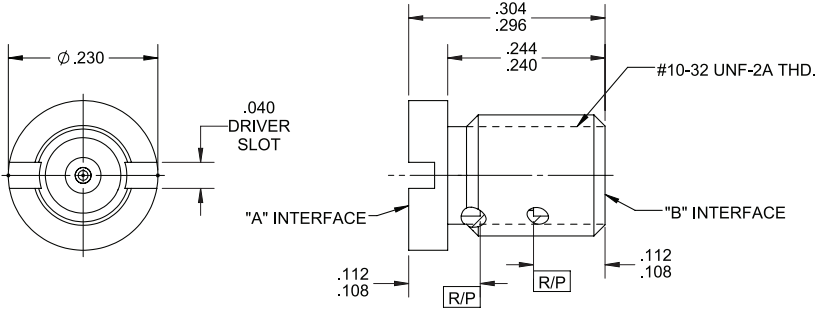

AXAX-0523-03



AXAX-0523-03

GPPO® Female Adapters

GPPO® Female to 1.85 mm Jack Adapter

Catalog Number	Recommended Tools	Assembly Procedure	Notes
1B1M1-0509-01	-	-	

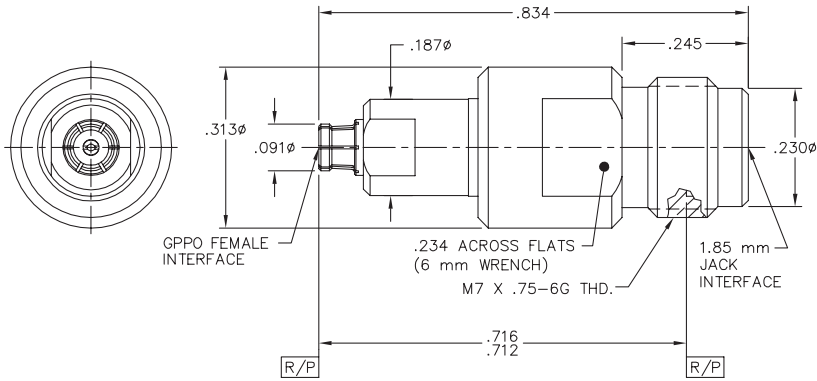

1B1M1-0509-01



1B1M1-0509-01

GPPO Female to 1.85 mm Plug Adapter

Catalog Number	Recommended Tools	Assembly Procedure	Notes
1B1M2-0509-01	-	-	

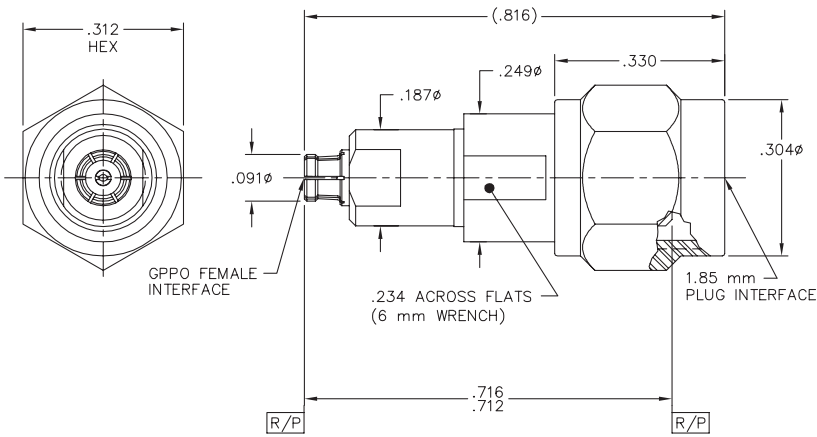

1B1M2-0509-01



1B1M2-0509-01

GPPO® Female Adapters

GPPO® Female to 2.4 mm Jack Adapter

Catalog Number	Recommended Tools	Assembly Procedure	Notes
1B1C1-0501-01	-	-	

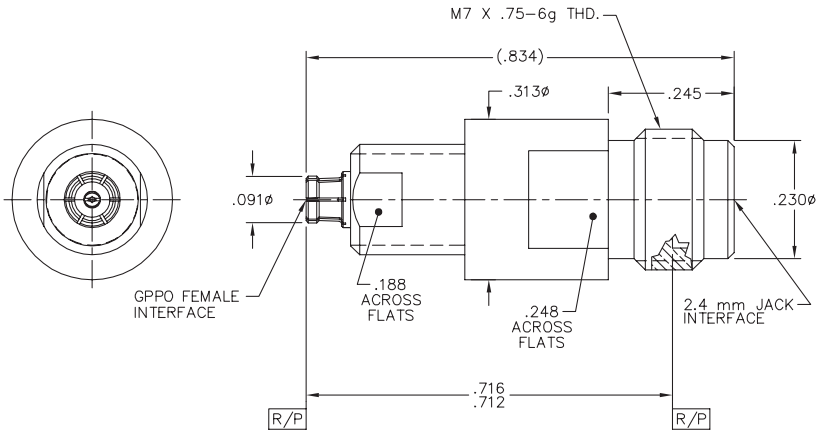

1B1C1-0501-01



1B1C1-0501-01

GPO Female to 2.4 mm Plug Adapter

Catalog Number	Recommended Tools	Assembly Procedure	Notes
1B1C2-0501-01	-	-	

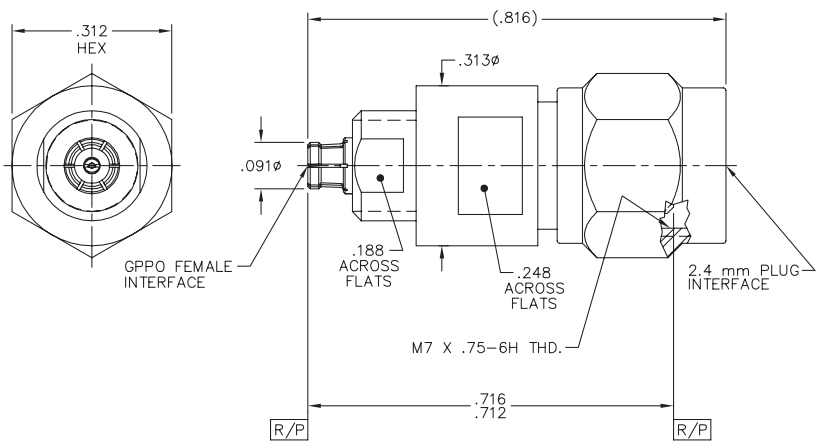

1B1C2-0501-01



1B1C2-0501-01

GPPO® Female Adapters

GPPO® Female to 2.92 mm Jack Adapter

Catalog Number	Recommended Tools	Assembly Procedure	Notes
1B1D1-0503-01	-	-	

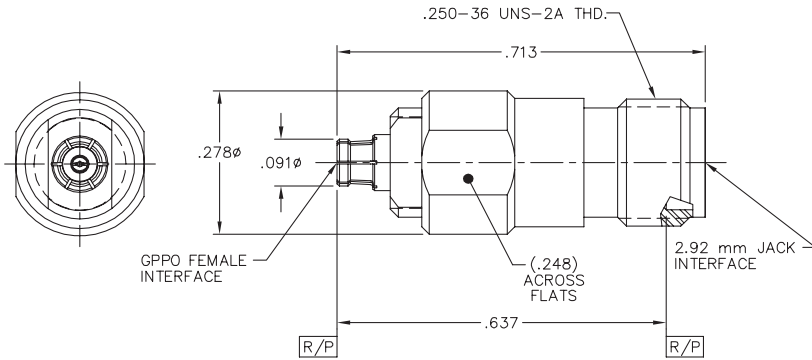

1B1D1-0503-01



1B1D1-0503-01

GPPO Female to SMA Jack Adapter

Catalog Number	Recommended Tools	Assembly Procedure	Notes
1B1F1-0503-01	-	-	

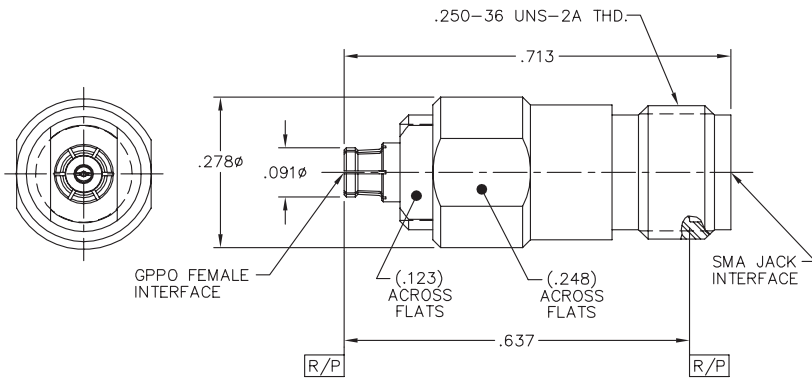

1B1F1-0503-01



1B1F1-0503-01

GPPO® Female Adapters

GPPO® Female to SMA Plug Adapter

Catalog Number	Recommended Tools	Assembly Procedure	Notes
1B1F2-0503-01	-	-	

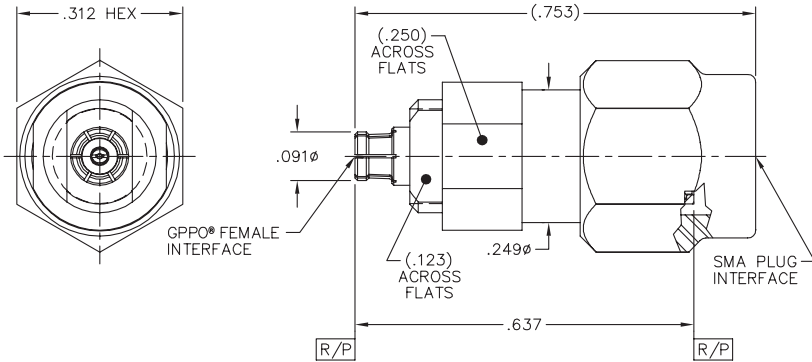

1B1F2-0503-01

1B1F2-0503-01

GPPO Female to GPO® Female Adapter

Catalog Number	Recommended Tools	Assembly Procedure	Notes
1B1A1-1509-01	-	-	

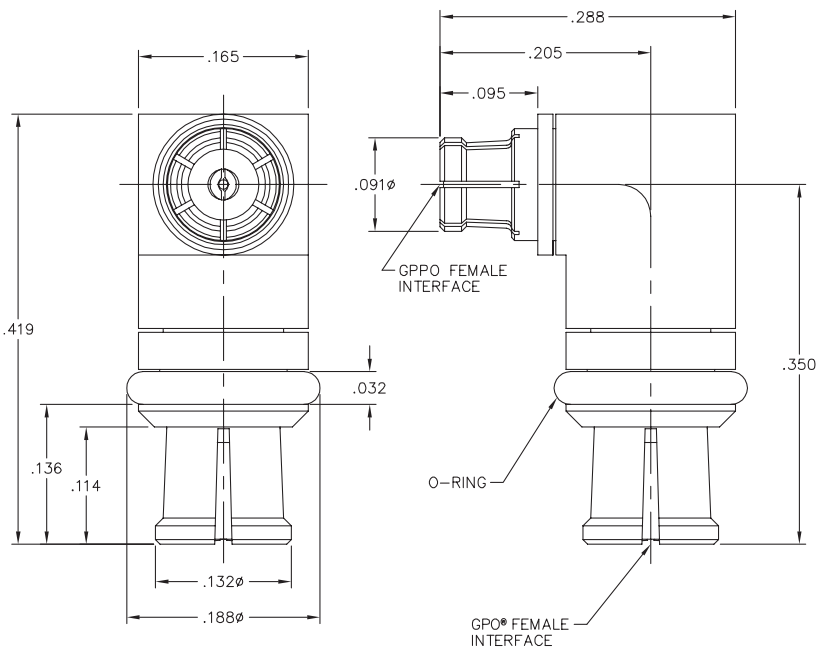

1B1A1-1509-01

1B1A1-1509-01

GPPO® Female Adapters

GPPO® Female to GPO® Male Adapter

Catalog Number	Recommended Tools	Assembly Procedure	Notes
1B1A3-0541-01	-	-	

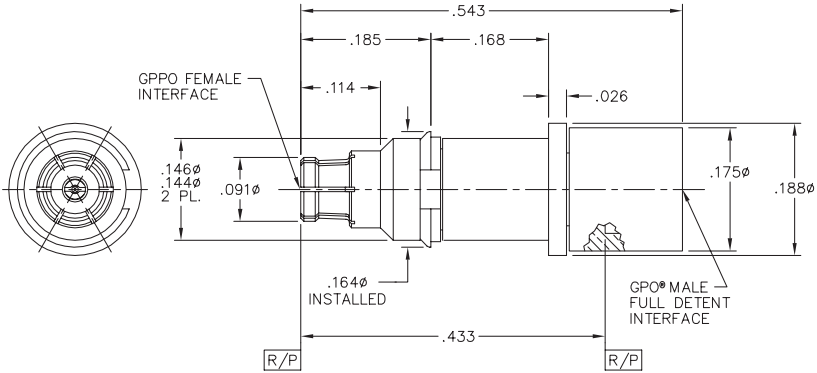

1B1A3-0541-01

1B1A3-0541-01

GPPO® Male Adapters

GPPO® Male to 1.85 mm Jack Adapter

Catalog Number	Recommended Tools	Assembly Procedure	Notes
1BXM1-0509-01	-	-	

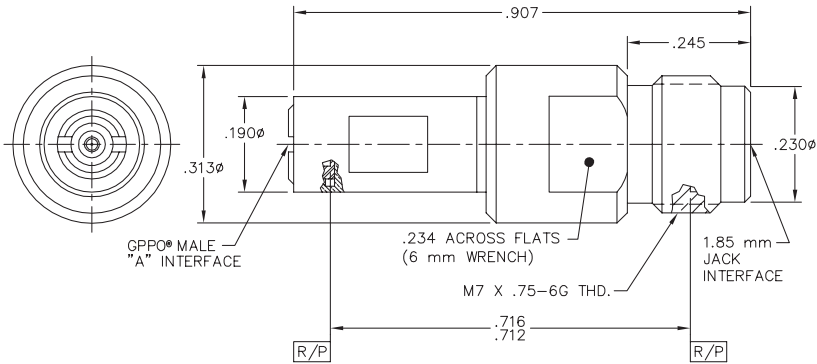

1BXM1-0509-01



1BXM1-0509-01

GPPO Male to 1.85 mm Plug Adapter

Catalog Number	Recommended Tools	Assembly Procedure	Notes
1BXM2-0509-01	-	-	

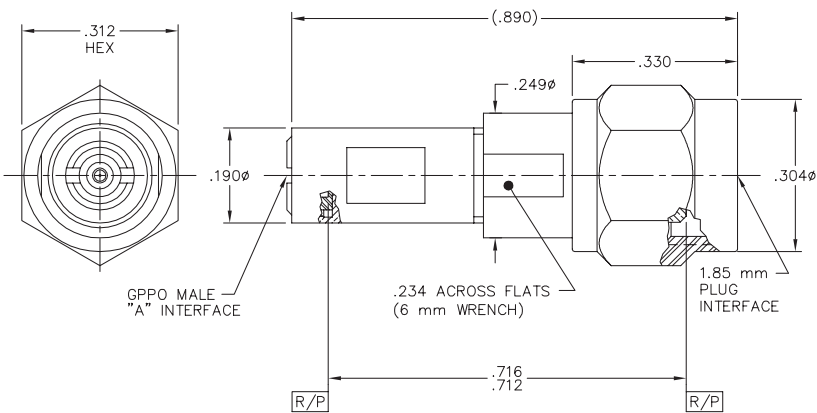

1BXM2-0509-01



1BXM2-0509-01

GPPO® Male Adapters

GPPO® Male to 2.4 mm Jack Adapter

Catalog Number	Recommended Tools	Assembly Procedure	Notes
1BXC1-0503-01	-	-	

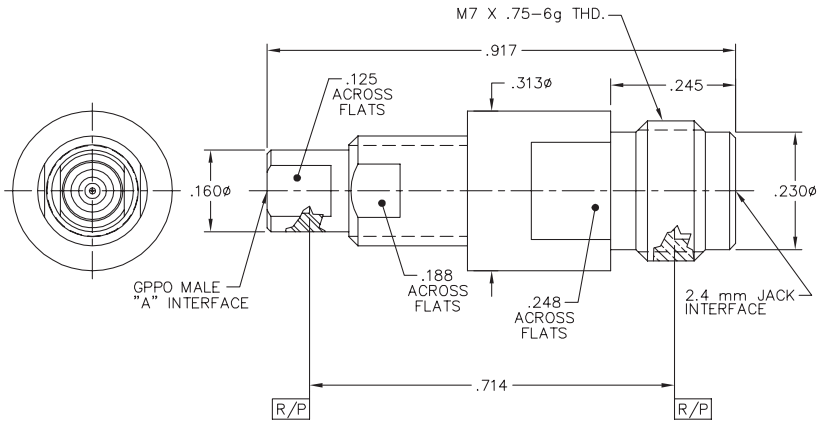

1BXC1-0503-01



1BXC1-0503-01

GPPO Male to 2.4 mm Plug Adapter

Catalog Number	Recommended Tools	Assembly Procedure	Notes
1BXC2-0503-01	-	-	

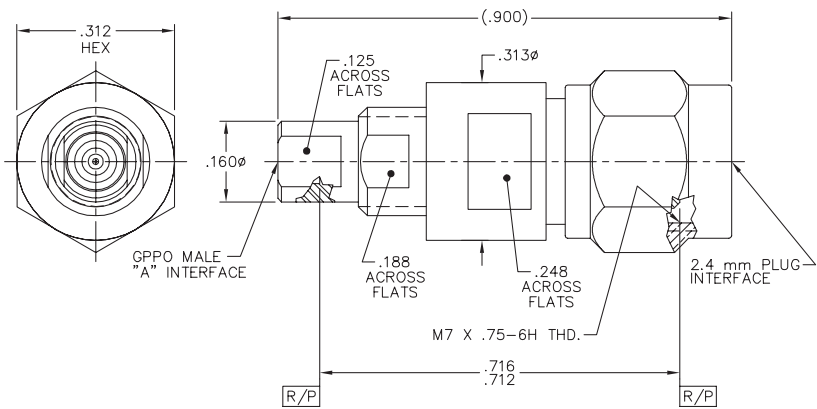

1BXC2-0503-01



1BXC2-0503-01

GPPO® Male Adapters

GPPO® Male to 2.92 mm Jack Adapter

Catalog Number	Recommended Tools	Assembly Procedure	Notes
1BXD1-0503-01	-	-	

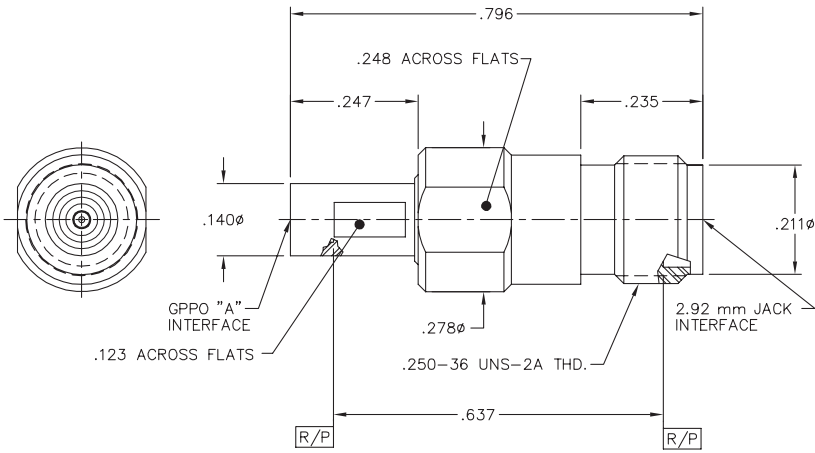

1BXD1-0503-01



1BXD1-0503-01

GPPO Male to 2.92 mm Plug Adapter

Catalog Number	Recommended Tools	Assembly Procedure	Notes
1BXD2-0503-01	-	-	

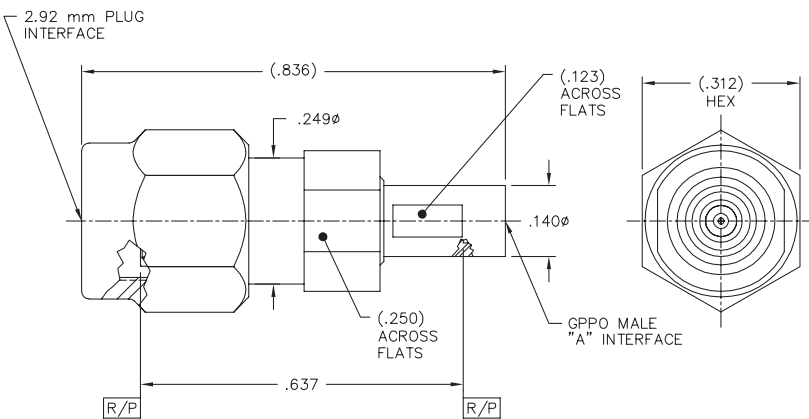

1BXD2-0503-01



1BXD2-0503-01

GPPO® Male Adapters

GPPO® Male to SMA Jack Adapter

Catalog Number	Recommended Tools	Assembly Procedure	Notes
1BXF1-0503-01	-	-	

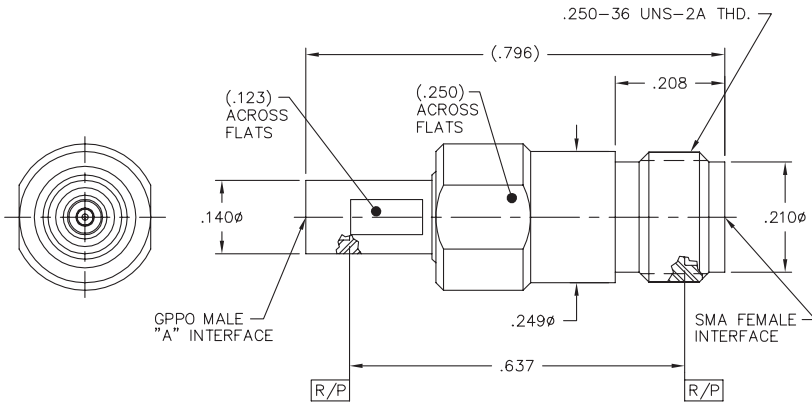

1BXF1-0503-01



1BXF1-0503-01

GPPO Male to SMA Plug Adapter

Catalog Number	Recommended Tools	Assembly Procedure	Notes
1BXF2-0503-01	-	-	

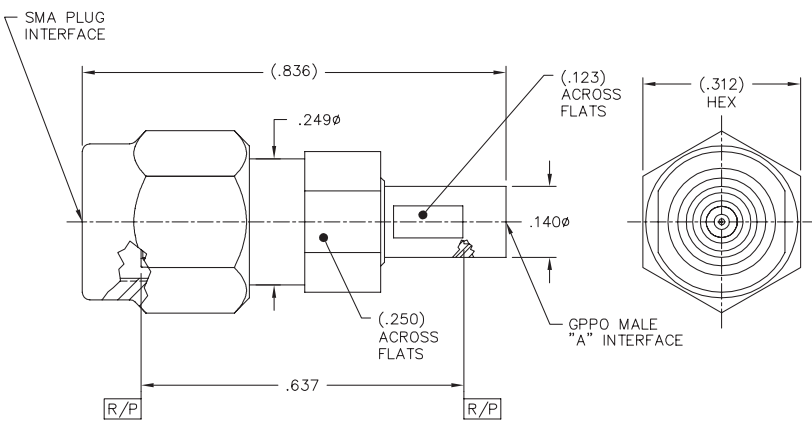

1BXF2-0503-01



1BXF2-0503-01

GPPO® Male Adapters

GPPO® Male to GPPO Male Adapter

Catalog Number	Recommended Tools	Assembly Procedure	Notes
BXBX-0523-02	-	-	

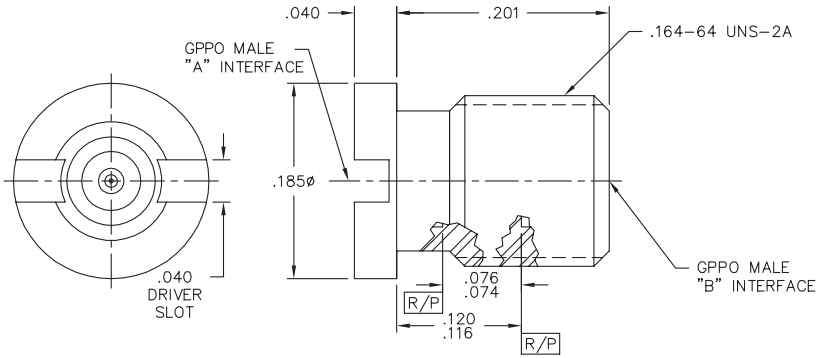

BXBX-0523-02



BXBX-0523-02

G3PO™ Female Adapters

G3PO™ Female to 1.85 mm Jack Adapter

Catalog Number	Recommended Tools	Assembly Procedure	Notes
1R1M1-0509-01	-	-	

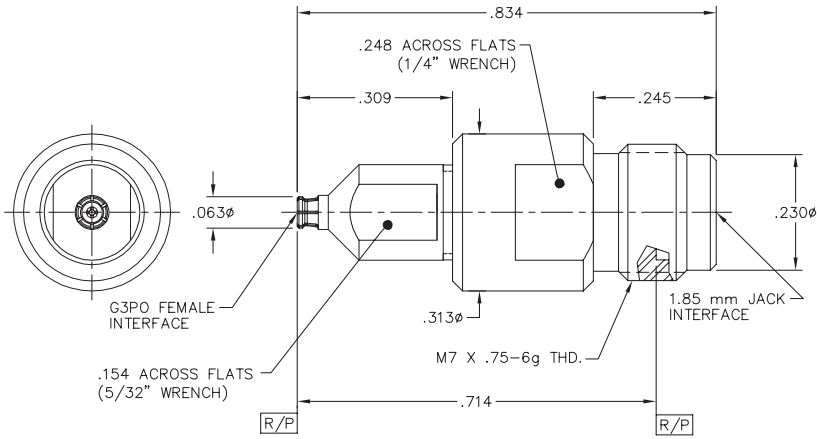

1R1M1-0509-01



1R1M1-0509-01

G3PO Female to 1.85 mm Plug Adapter

Catalog Number	Recommended Tools	Assembly Procedure	Notes
1R1M2-0509-01	-	-	

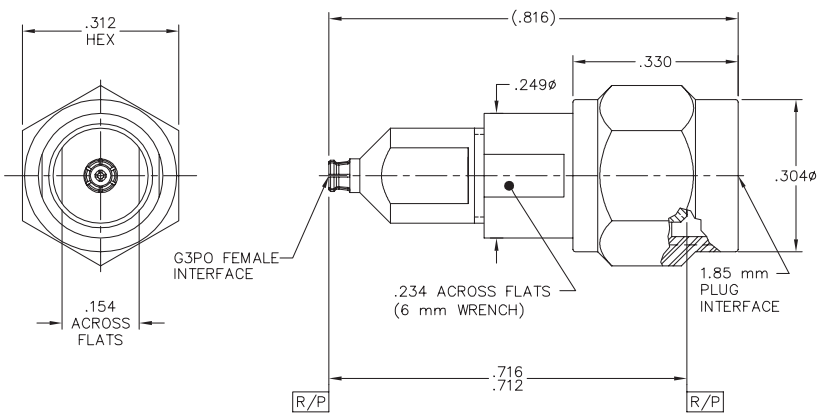

1R1M2-0509-01



1R1M2-0509-01

G3PO™ Female Adapters

G3PO™ Female to 2.4 mm Jack Adapter

Catalog Number	Recommended Tools	Assembly Procedure	Notes
1R1C1-0501-01	-	-	

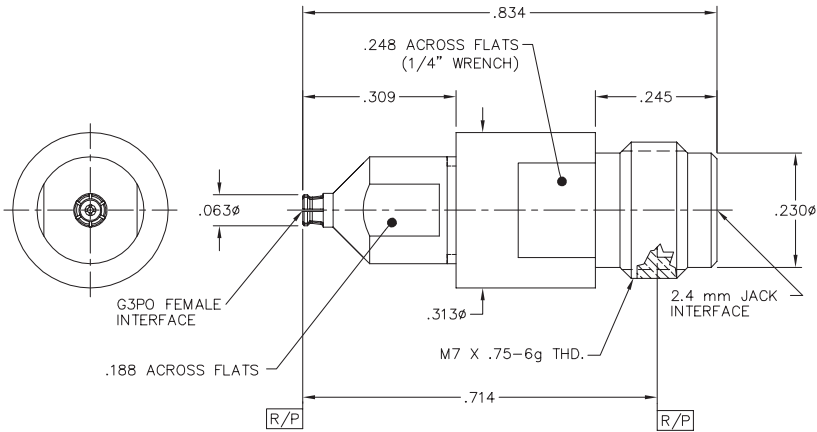

1R1C1-0501-01



1R1C1-0501-01

G3PO Female to 2.92 mm Jack Adapter

Catalog Number	Recommended Tools	Assembly Procedure	Notes
1R1D1-0503-01	-	-	

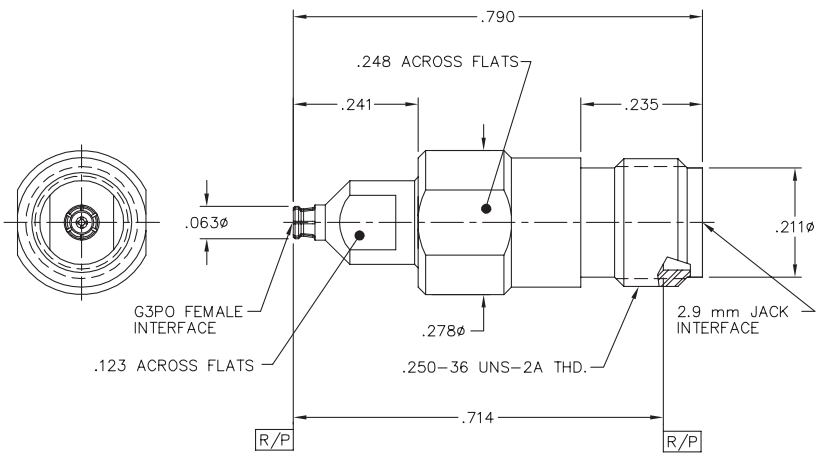

1R1D1-0503-01



1R1D1-0503-01

G3PO™ Female Adapters

G3PO™ Female to SMA Jack Adapter

Catalog Number	Recommended Tools	Assembly Procedure	Notes
1R1F1-0503-01	-	-	

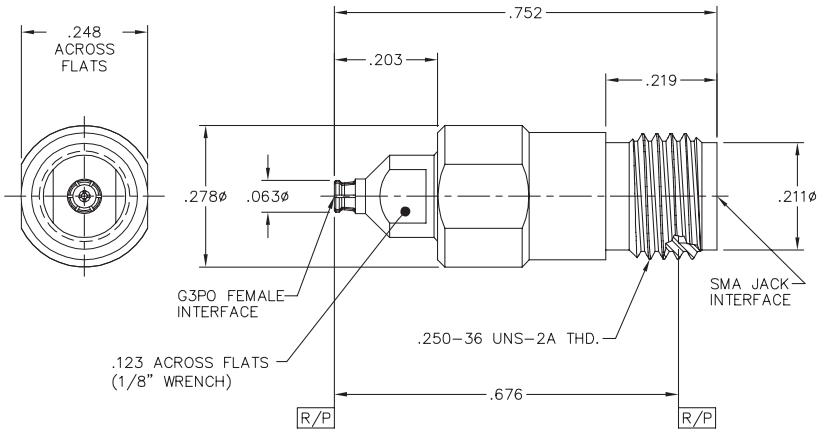

1R1F1-0503-01

1R1F1-0503-01

G3PO™ Male Adapters

G3PO™ Male to 1.85 mm Jack Adapter

Catalog Number	Recommended Tools	Assembly Procedure	Notes
1RXM1-0503-01	-	-	

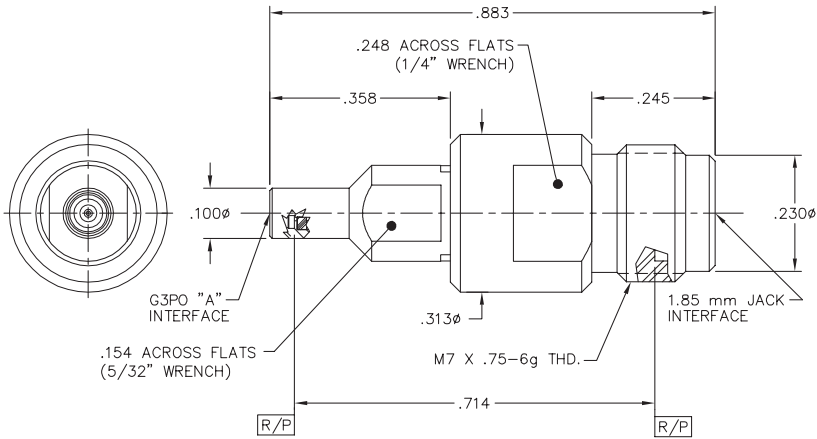

1RXM1-0503-01



1RXM1-0503-01

G3PO Male to 1.85 mm Plug Adapter

Catalog Number	Recommended Tools	Assembly Procedure	Notes
1RXM2-0503-01	-	-	

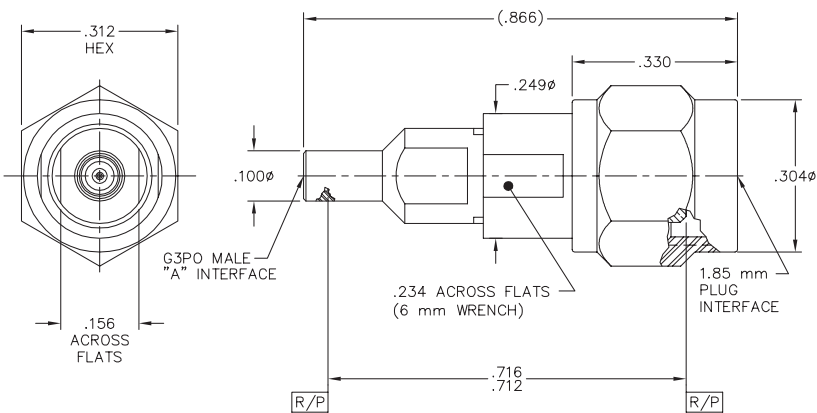

1RXM2-0503-01



1RXM2-0503-01

G3PO™ Male Adapters

G3PO™ Male to 2.4 mm Jack Adapter

Catalog Number	Recommended Tools	Assembly Procedure	Notes
1RXC1-0503-01	-	-	

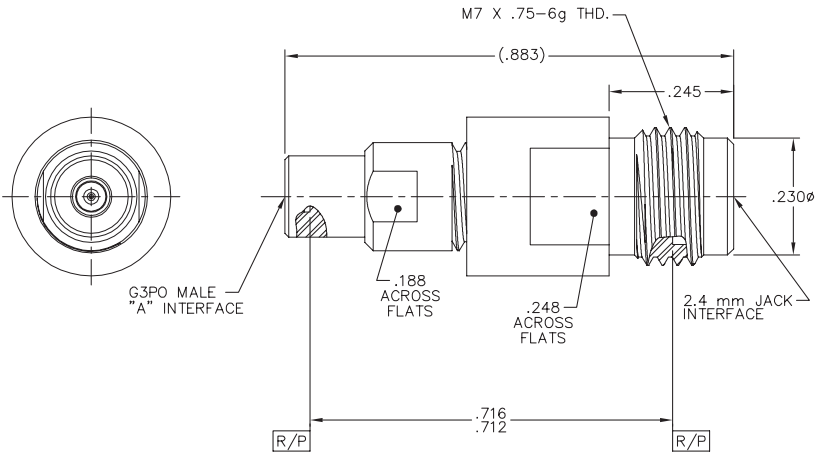

1RXC1-0503-01



1RXC1-0503-01

G3PO Male to 2.92 mm Jack Adapter

Catalog Number	Recommended Tools	Assembly Procedure	Notes
1RXD1-0503-01	-	-	

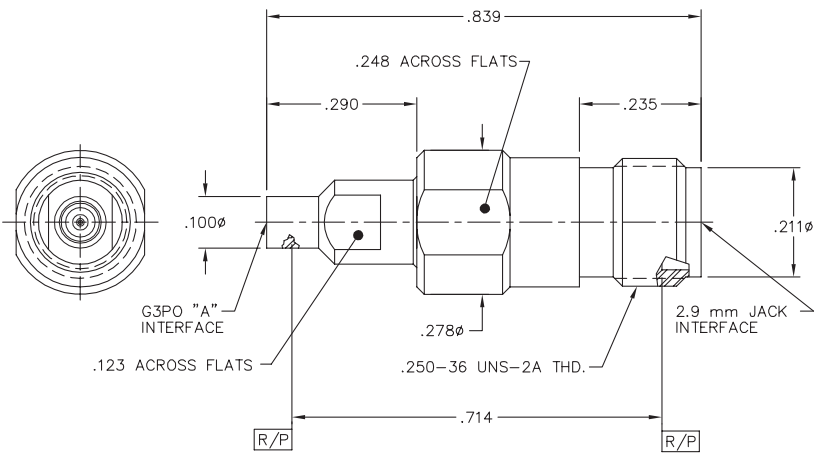

1RXD1-0503-01



1RXD1-0503-01

G3PO™ Male Adapters

G3PO™ Male to 2.92 mm Plug Adapter

Catalog Number	Recommended Tools	Assembly Procedure	Notes
1RXD2-0503-01	-	-	

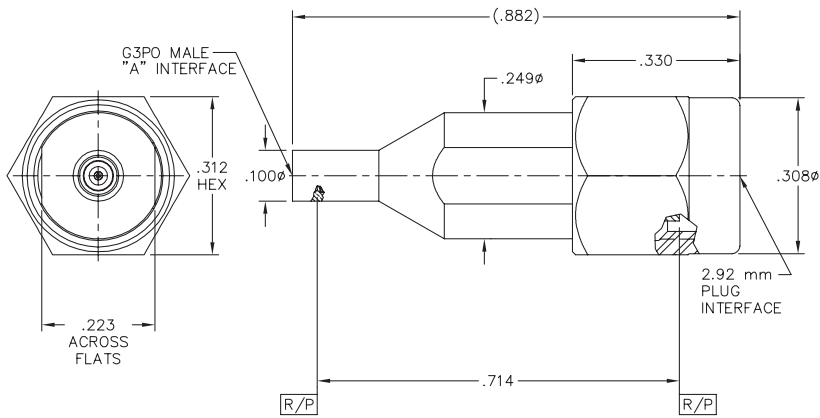

1RXD2-0503-01



1RXD2-0503-01

G3PO Male to SMA Jack Adapter

Catalog Number	Recommended Tools	Assembly Procedure	Notes
1RXF1-0509-01	-	-	

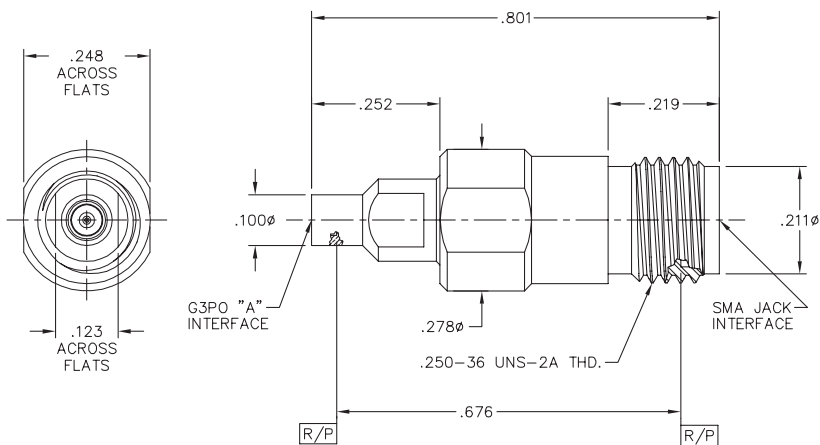

1RXF1-0509-01



1RXF1-0509-01

G3PO™ Male Adapters

G3PO™ Male to SMA Plug Adapter

Catalog Number	Recommended Tools	Assembly Procedure	Notes
1RXF2-0503-01	-	-	

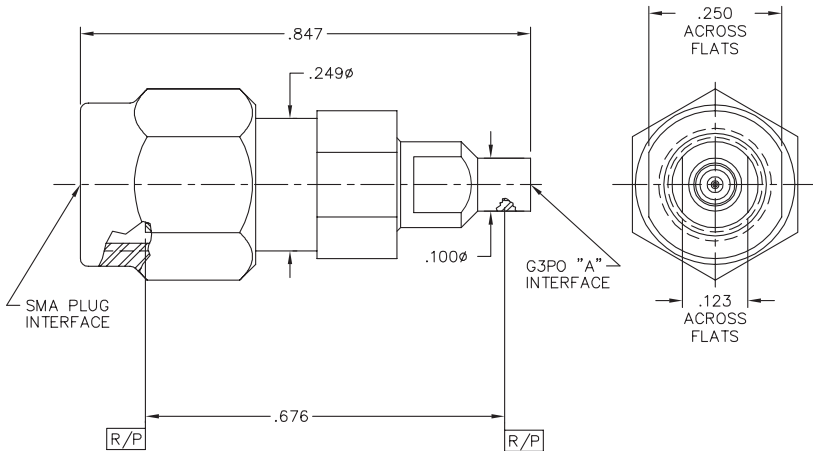

1RXF2-0503-01



1RXF2-0503-01

G3PO Male to G3PO Female Adapter

Catalog Number	Recommended Tools	Assembly Procedure	Notes
R1R5-0501-01	-	-	

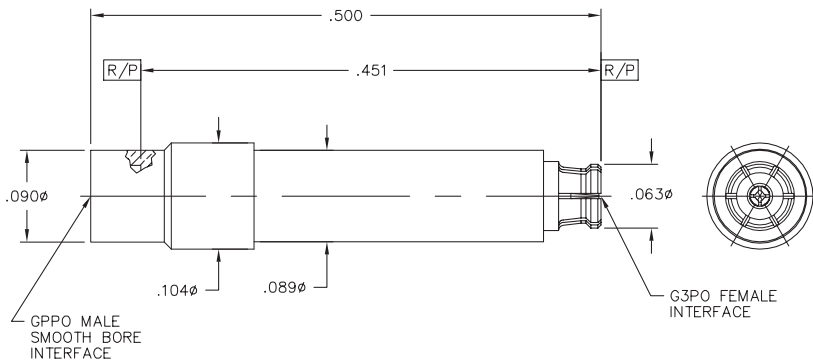

R1R5-0501-01



R1R5-0501-01

G4PO™ Male Adapters

G4PO™ Male to 1.85 mm Jack Adapter

Catalog Number	Recommended Tools	Assembly Procedure	Notes
1SXM1-0503-01	-	-	

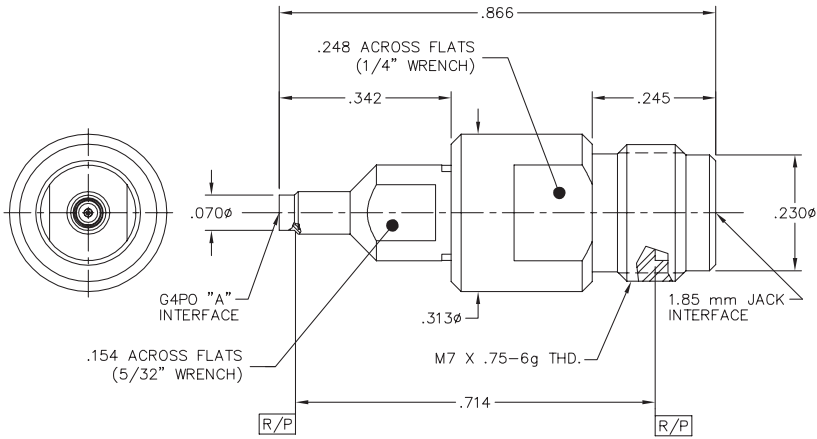

1SXM1-0503-01



1SXM1-0503-01

G4PO Male to 2.92 mm Plug Adapter

Catalog Number	Recommended Tools	Assembly Procedure	Notes
1SXD2-0503-01	-	-	

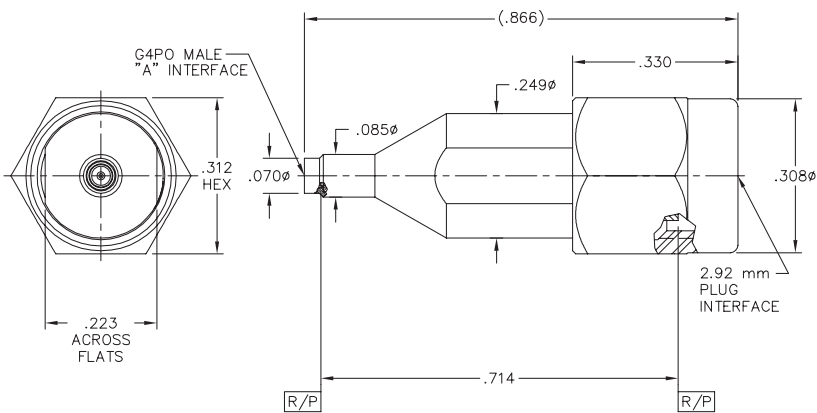

1SXD2-0503-01



1SXD2-0503-01

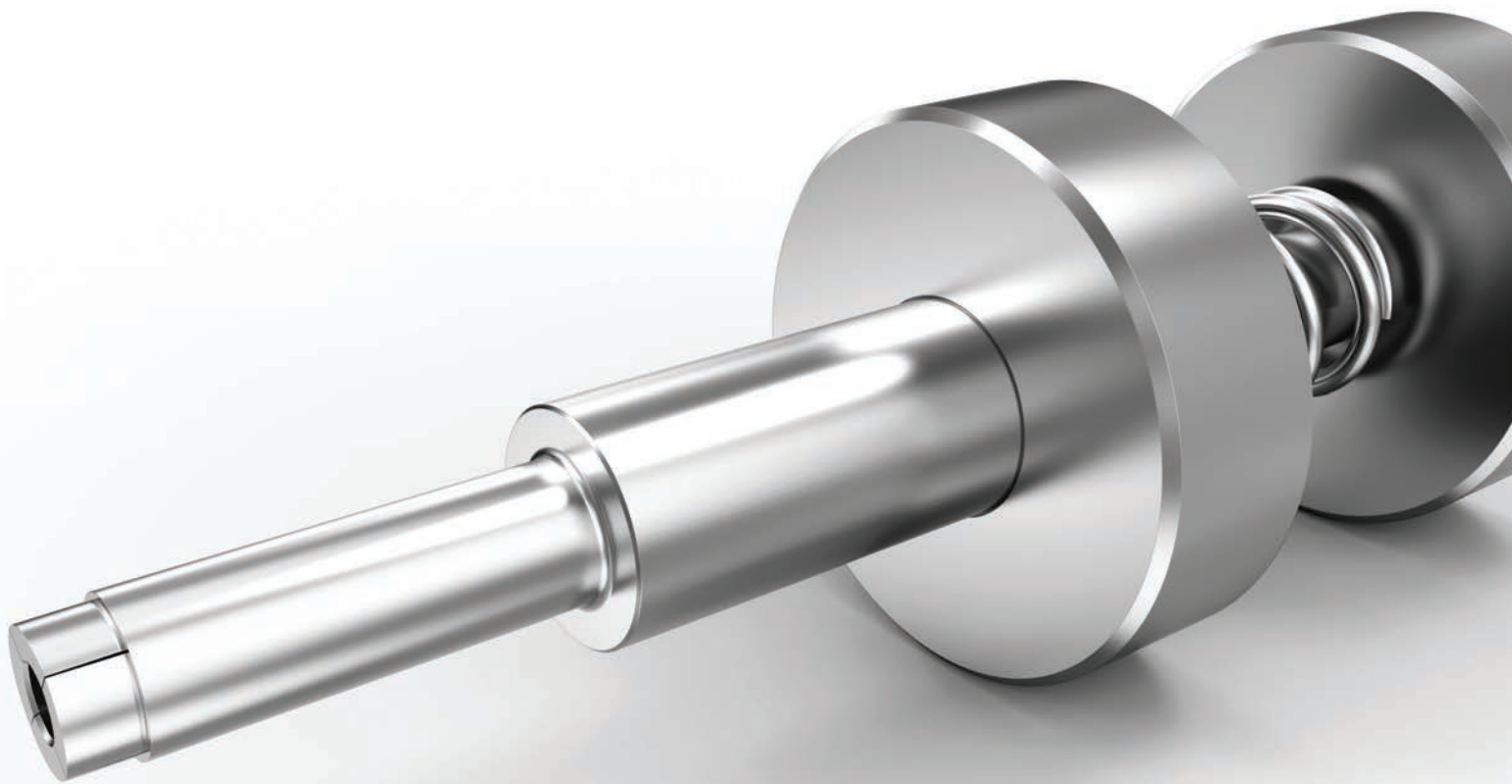

Tools

- From GPO® to G4PO™, Corning offers installation and removal tools in plunger styles, 90 degree pry bar styles, and straight pry bar styles
- We recognize precision and performance matter, which is why our product portfolio also includes a range of drivers, locating tools, centering tools, holding fixtures, and more

Installation/Removal Tools

Blind Mate Interconnect (Bullet) Installation/Removal Tools

Catalog Number	Notes	Package Dimensions (Inches)
A095-A99-01	GPO® Install/Removal Tool, plunger style	2.79 length, Ø1.00 max
A095-A99-03	GPO Low-Impact Removal Tool, plunger style	2.87 length, Ø1.00 max
B095-A99-01	GPPO® Install/Removal Tool, plunger style	2.79 length, Ø1.00 max
B095-A99-05	GPPO Low-Impact Removal Tool, plunger style	2.86 length, Ø1.00 max
R095-A99-01	G3PO™ Low-Profile Install/Removal Tool, plunger style	2.36 length, Ø1.00 max
S094-A91-01	G4PO™ Insertion Tool, plunger style	3.00 length, Ø0.25 max
S095-A99-01	G4PO Removal Tool, plunger style	4.25 length, Ø0.25 max

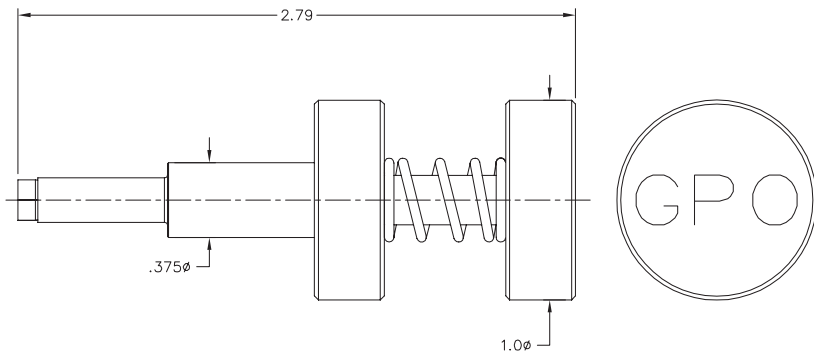

A095-A99-01



A095-A99-01

Installation/Removal Tools

Straight Cable Connector Removal Tools

Catalog Number	Notes	Package Dimensions (Inches)
A098-A99-10	GPO® Removal Tool, plunger style	1.62 length, 0.35 tip, 0.77 grip
A098-A99-02	GPO Removal Tool, straight pry bar style	2.50 length, 0.50 width, 0.03 height
A098-A99-03	GPO Removal Tool, 90-degree pry bar style	3.35 length, 0.25 width, 0.80 height
B098-A99-08	GPPO® Removal Tool, plunger style	1.62 length, 0.35 tip, 0.77 grip
B098-A99-07	GPPO Removal Tool, plunger style	4.31 length, Ø1.00 max
B098-A99-03	GPPO Removal Tool, straight pry bar style	3.00 length, 0.50 width, 0.30 height
B098-A99-02	GPPO Removal Tool, 30-degree pry bar style	3.00 length, 0.50 width, 0.60 height
B098-A99-04	GPPO Removal Tool, 90-degree pry bar style	6.00 length, 0.38 width, 0.32 height
R098-A99-01	G3PO™ Removal Tool, straight pry bar style	3.00 length, 0.50 width, 0.30 height
R098-A99-02	G3PO Removal Tool, straight pry bar style	2.80 height, 0.50 width, 0.30 height

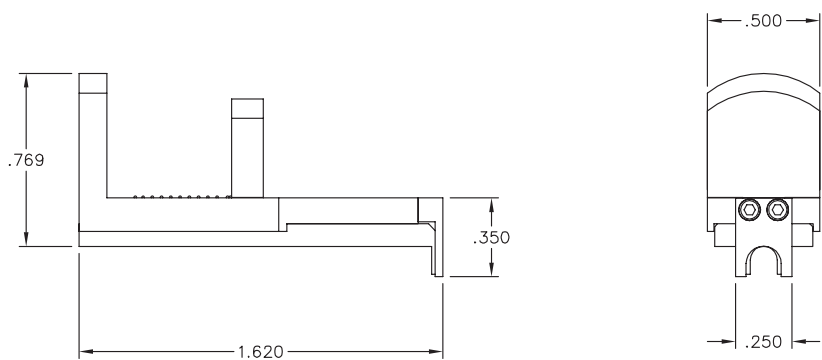

A098-A99-10

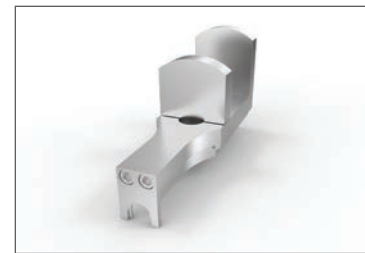

A098-A99-10

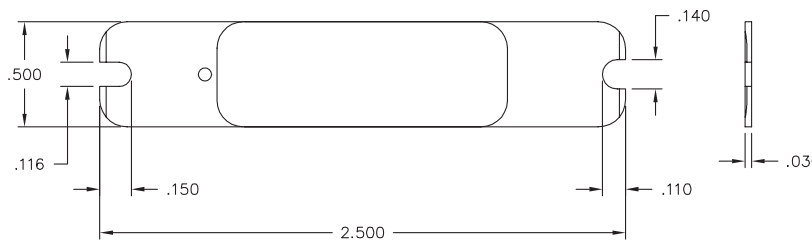

A098-A99-02



A098-A99-02

Installation/Removal Tools

Right-Angle (R/A) Cable Connector/Installation Removal Tools

Catalog Number	Notes	Package Dimensions (Inches)
A098-A98-08	GPO® Right-Angle Removal Tool, plunger style	4.31 length, Ø1.00 max
A098-A99-04	GPO Female Right-Angle Install Tool	2.50 length, Ø0.31 max
A098-A99-01	GPO Right-Angle Removal Tool, 90-degree pry bar style	2.50 length, 0.38 width, 0.32 height
B098-A99-01	GPPO® Female Right-Angle Install Tool	2.40 length, Ø0.31 max

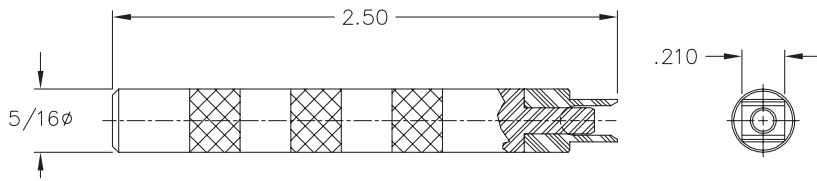

A098-A99-04



A098-A99-04

Female Snap-In Removal Tools

Catalog Number	Notes	Package Dimensions (Inches)
9001-824-0	GPO Removal Tool, plunger style	4.15 length, Ø0.75 max
A098-A99-05	GPO Snap-In Float-Mount Removal Tool	3.04 length, Ø1.00 max

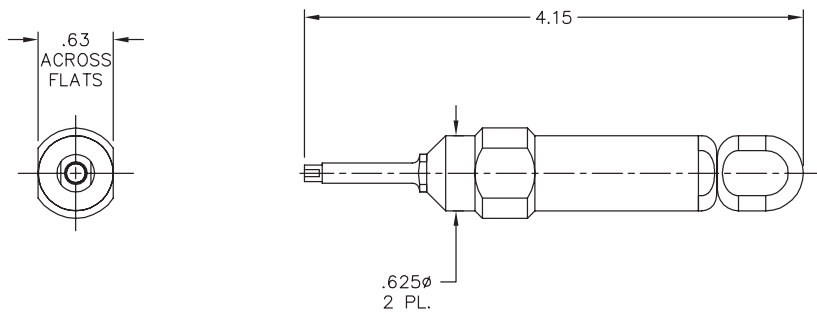

9001-824-0



9001-824-0

Installation/Removal Tools

Male Snap-In Removal Tools

Catalog Number	Notes	Package Dimensions (Inches)
9001-820-4	GPO® Removal Tool, plunger style	4.00 length, Ø1.14 max
9001-823-0	GPPO® Removal Tool, plunger style	4.00 length, Ø0.75 max
9001-819-4	GPPO Removal Tool, plunger style	4.00 length, Ø1.14 max

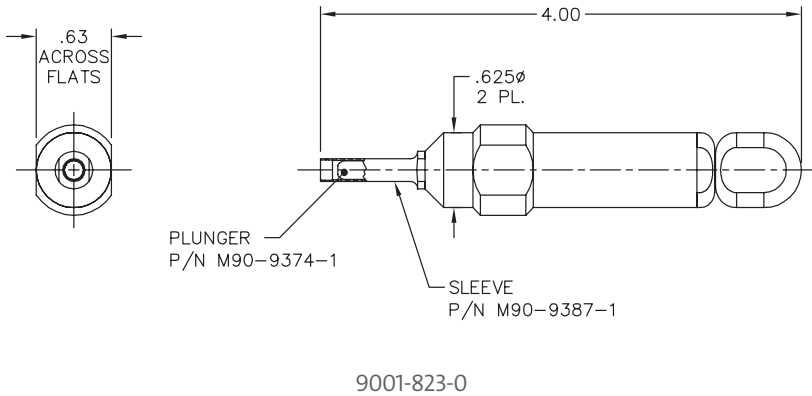

9001-823-0

Female Load Removal Tools

Catalog Number	Notes	Package Dimensions (Inches)
A093-A99-01	GPO No-Impact Load Removal Tool	2.87 length, Ø1.00 max

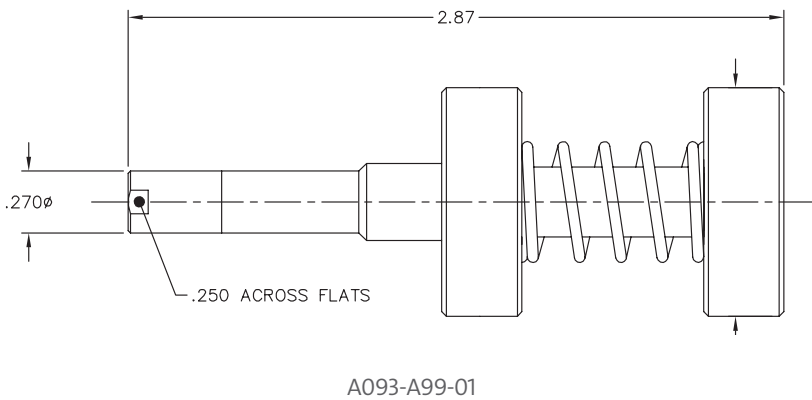

A093-A99-01

Driver Tools

Thread-In Drivers

Catalog Number	Notes	Package Dimensions (Inches)
A097-A99-01	GPO® Full-Detent Driver	2.50 length, Ø0.36 max
A097-A99-02	GPO Limited-Detent Driver	2.50 length, Ø0.36 max
A097-A99-03	GPO Smooth-Bore Driver	2.50 length, Ø0.36 max
A097-A99-07	GPO Load-Shroud Driver	2.50 length, Ø0.41 max
B097-A99-01	GPPO® Full-Detent Driver	2.50 length, Ø0.36 max
B097-A99-02	GPPO Smooth-Bore Driver	2.50 length, Ø0.36 max

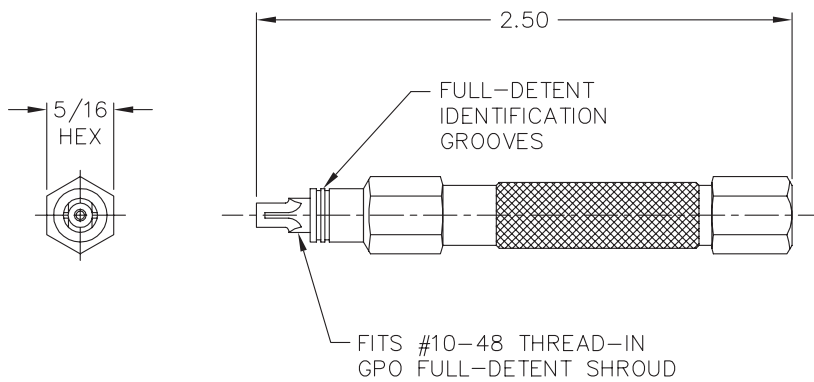

A097-A99-01



A097-A99-01

Thread-On Drivers

Catalog Number	Notes	Package Dimensions (Inches)
A097-A99-04	GPO Full-Detent Driver	2.50 length, Ø0.36 max
A097-A99-05	GPO Limited-Detent Driver	2.50 length, Ø0.36 max
A097-A99-06	GPO Smooth-Bore Driver	2.50 length, Ø0.36 max

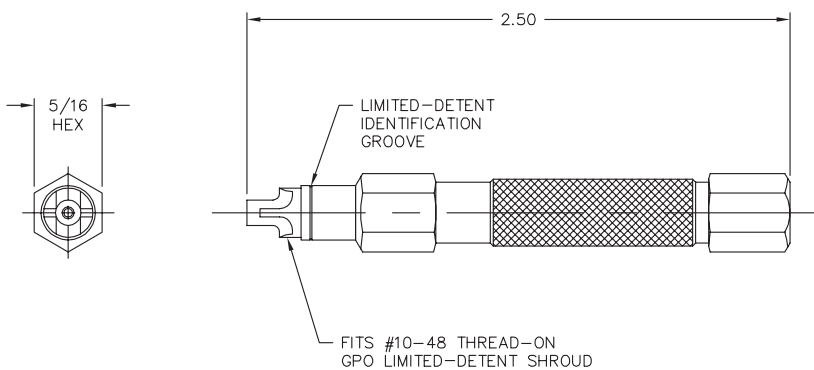

A097-A99-04



A097-A99-04

Driver Tools

Shroud Drivers

Catalog Number	Notes	Package Dimensions (Inches)
B097-A99-04	GPPO® Full-Detent Driver	0.85 length, Ø0.29 max

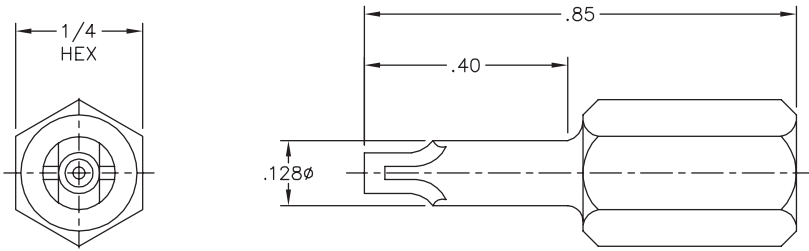

B097-A99-04



B097-A99-04

Locating Tools

Interface Locating Tools

Catalog Number	Notes	Package Dimensions (Inches)
A096-A99-02	GPO® Locator Tool, 5/16-18 UNC-2A outer thread	2.50 length, Ø0.58 max
A096-A99-03	GPO Locator Tool, 5/16-18 UNC-2A outer thread	2.50 length, Ø0.58 max
A096-A99-04	GPO Locator Tool, 5/16-18 UNC-2A outer thread	2.50 length, Ø0.58 max
A096-A99-09	GPO Locator Tool, 5/16-18 UNC-2A outer thread	2.50 length, Ø0.58 max
A096-A99-06	GPO Locator Tool, 5/16-18 UNC-2A outer thread	2.50 length, Ø0.58 max
9001-984-0	GPO Locator Tool, 5/16-18 UNC-2A outer thread	2.50 length, Ø0.58 max
B096-A99-01	GPPO Full-Detent Locator Tool	2.50 length, Ø0.58 max
B096-A99-02	GPPO Smooth-Bore Locator Tool	2.50 length, Ø0.58 max

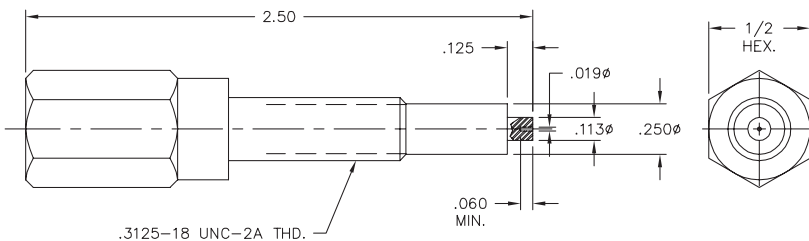

A096-A99-03



A096-A99-03

Locating Tools

Right-Angle Locating Tools

Catalog Number	Notes	Package Dimensions (Inches)
A096-A99-07	GPO® Locator Tool, 5/16-18 UNC-2A outer thread	2.50 length, Ø0.58 max
A096-A99-08	GPO Locator Tool, 5/16-18 UNC-2A outer thread	2.50 length, Ø0.58 max
A096-A99-10	GPO Locator Tool, 5/16-18 UNC-2A outer thread	2.50 length, Ø0.58 max

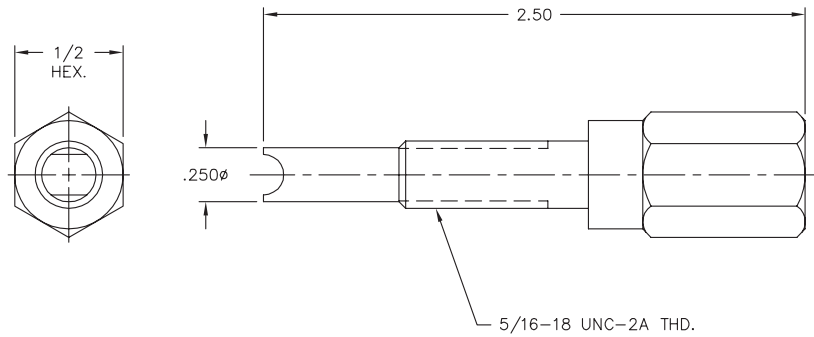

A096-A99-07



A096-A99-07

Contact Locating Tools

Catalog Number	Notes	Package Dimensions (Inches)
R096-A95-01	G3PO™ Female Contact Locator	0.30 length, Ø0.19 max
R096-A23-01	G3PO Male Full-Detent Contact Locator	0.30 length, Ø0.19 max
R096-A25-01	G3PO Male Smooth-Bore Contact Locator	0.30 length, Ø0.19 max

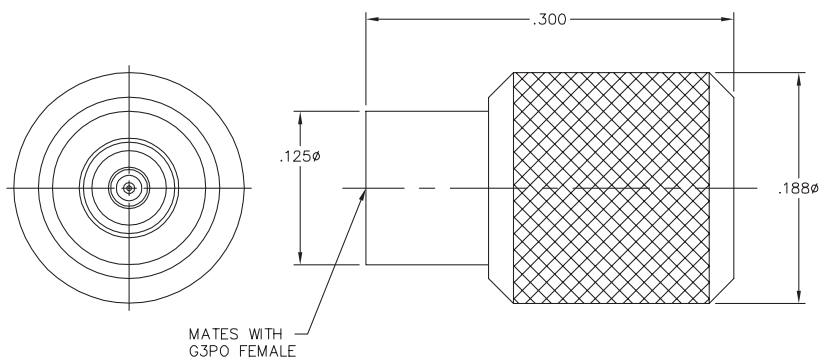

R096-A95-01



R096-A95-01

Retaining Tools

Contact Retaining Tools

Catalog Number	Notes	Package Dimensions (Inches)
A096-A99-01	GPO® Contact Retainer	0.50 length, Ø0.25 max
B096-A93-01	GPPO® Contact Retainer	0.30 length, Ø0.19 max

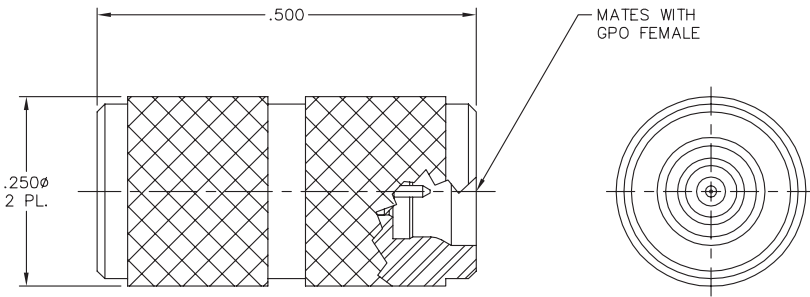

A096-A99-01

A096-A99-01

Seal Locating Tools

Seal Locating Tools for Thread-In Shrouds

Catalog Number	Notes	Package Dimensions (Inches)
A090-A99-01	GPO Seal Locator, #10-48 UNS-2A outer thread	0.50 length, Ø0.25 max
B090-A99-05	GPPO Seal Locator, .164-64 UNS-2A outer thread	0.50 length, Ø0.25 max

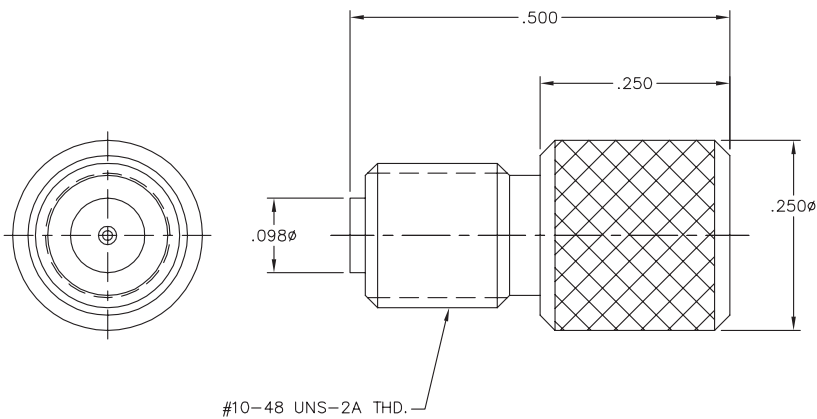

A090-A99-01

A090-A99-01

Seal Locating Tools

Seal Locators for Flanged Connectors

Catalog Number	Notes	Package Dimensions (Inches)
A090-A99-10	GPO® Flange Seal Locator for .282 hole spacing	0.65 length, Ø0.24 max
A090-A99-11	GPO Flange Seal Locator for .328 hole spacing	0.65 length, Ø0.24 max
A090-A99-09	GPO Flange Seal Locator for .481 hole spacing	0.65 length, Ø0.24 max
B090-A99-09	GPPO® Flange Seal Locator for .282 hole spacing	0.50 length, Ø0.13 max
B090-A99-08	GPPO Flange Seal Locator for .481 hole spacing	0.50 length, Ø0.13 max

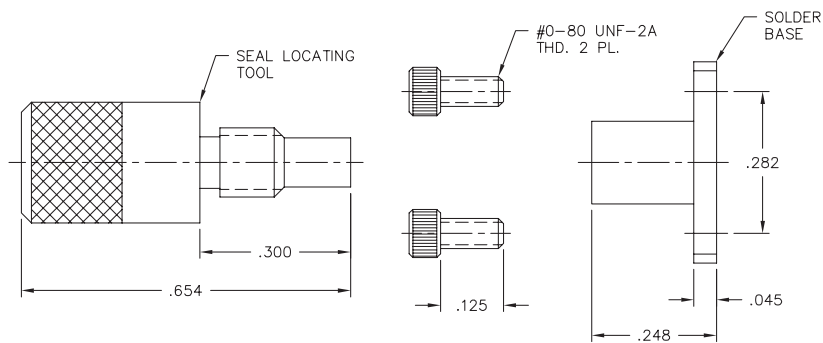

A090-A99-10

A090-A99-10

Seal Locators for Center Conductors

Catalog Number	Notes	Package Dimensions (Inches)
9001-923-3	Seal Locating Fixture for Ø .018 center conductor	0.50 length, Ø0.33 max
A090-A99-07	Seal Locating Fixture for Ø .012 center conductor, 1/4-36 UNS-2A outer thread	0.50 length, Ø0.33 max
B090-A99-07	Seal Locating Fixture for Ø .009 center conductor, M6 x .75-6g outer thread	0.50 length, Ø0.33 max

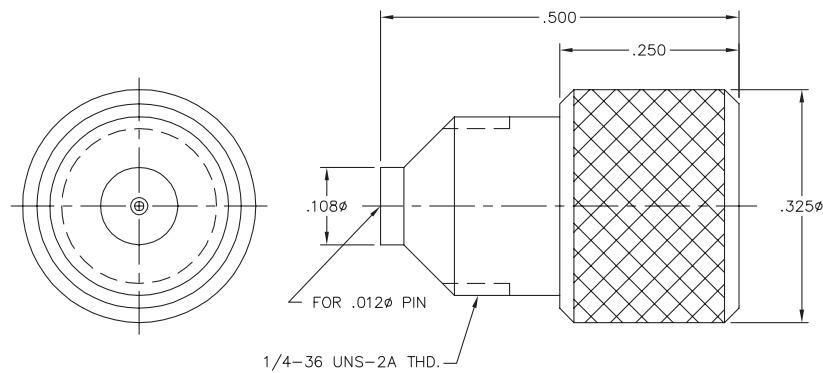

A090-A99-07

A090-A99-07

Centering Tools

Shroud Centering Tools

Catalog Number	Notes	Package Dimensions (Inches)
A090-A99-03	GPO® Shroud Centering Tool for \varnothing .015 center conductor	0.62 length, \varnothing 0.19 max
B090-A99-01	GPPO® Shroud Centering Tool	0.60 length, \varnothing 0.19 max
B090-A99-02	GPPO Smooth-Bore Shroud Centering Tool	0.60 length, \varnothing 0.19 max

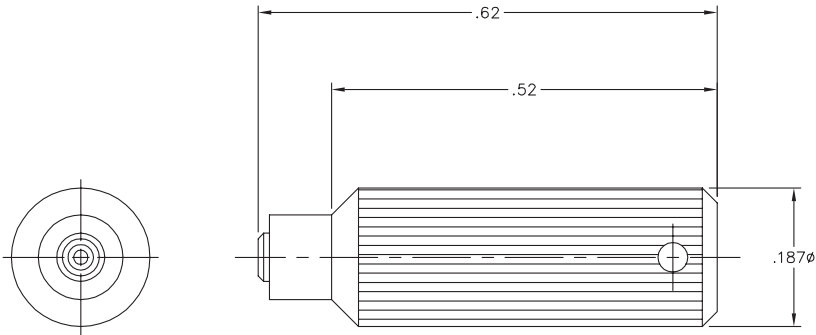

A090-A99-03



A090-A99-03

Seal Centering Tools for Press-In Shrouds

Catalog Number	Notes	Package Dimensions (Inches)
B090-A99-06	GPPO Seal Centering Tool for press-in shroud	0.32 length, \varnothing 0.17 max

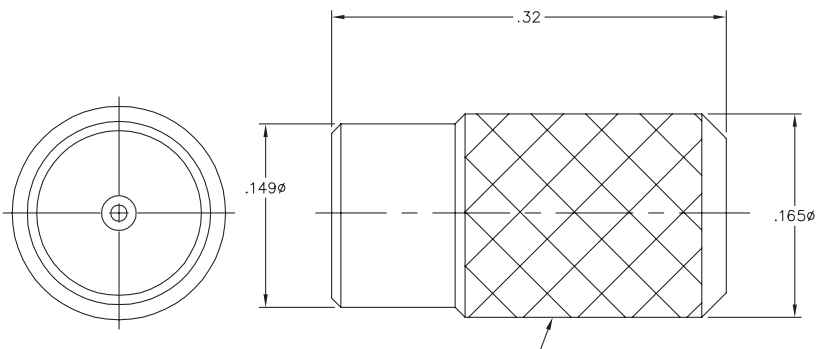

A090-A99-10



B090-A99-06

Cable Fixtures

Cable Holding Fixtures

Catalog Number	Notes	Package Dimensions (Inches)
L096-A99-05	Cable Holding Fixture, no cable inserts	2.50 length, 0.73 width, 1.50 height
L096-A99-02	Cable Holding Fixture with inserts for .047 S/R cable	2.50 length, 0.73 width, 1.50 height
OMNI Model No. T-4567	Cable Holding Fixture for .047 S/R cable, see L096-A99-02	2.50 length, 0.73 width, 1.50 height
L096-A99-07	Inserts for .047 S/R cable	2 x 0.50 length, 0.50 width, 0.28 height
L096-A99-01	Cable Holding Fixture with inserts for .086 S/R cable	2.50 length, 0.73 width, 1.50 height
OSI Model No. T-4567	Cable Holding Fixture for .086 S/R cable, see L096-A99-01	2.50 length, 0.73 width, 1.50 height
L096-A99-06	Inserts for .086 S/R cable	2 x 0.50 length, 0.50 width, 0.28 height
L096-A99-10	Cable Holding Fixture for .141 cable	2.50 length, 0.73 width, 1.50 height

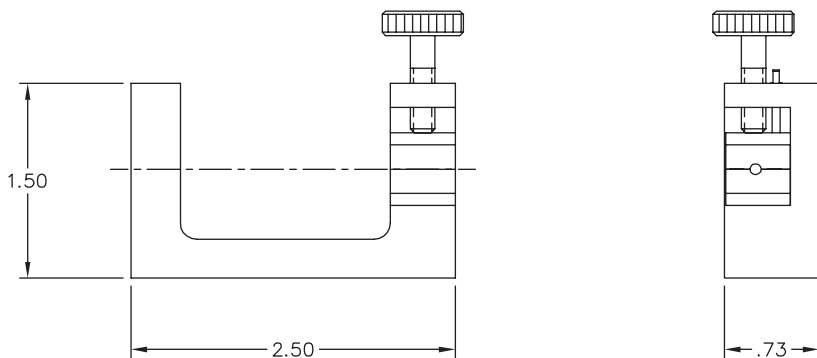

L096-A99-01



L096-A99-01

Cable Assembly Clamp Nut Torque Tool

Catalog Number	Notes	Package Dimensions (Inches)
L096-A99-12	Cable Assembly Clamp Nut Torque Tool	3.0 length, Ø0.29 max

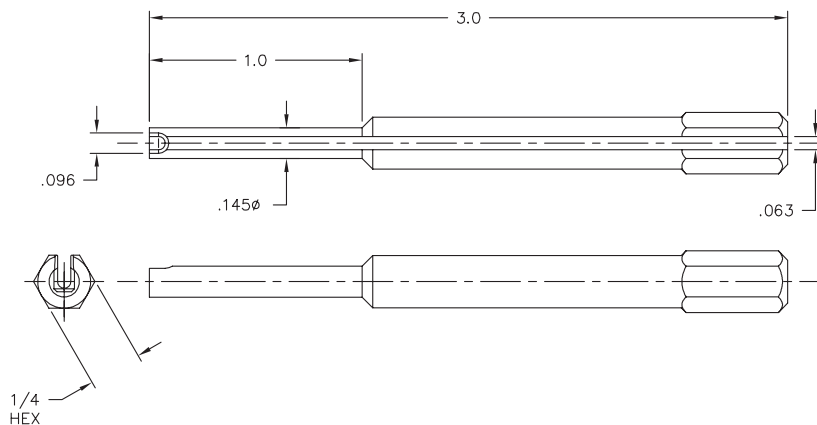

L096-A99-12



L096-A99-12

Miscellaneous

Interface Gauges

Catalog Number	Notes
9160-112-3	GPO® Contact Interface Gauge for male bulkhead shrouds
9160-110-3	GPO Dielectric Interface Gauge
9160-107-3	GPO Female Contact Interface Gauge
9160-108-3	GPO Female Dielectric Interface Gauge
9160-109-3	GPO Male Contact Interface Gauge
9160-123-3	GPPO® Male Dielectric Interface Gauge
9160-115-3	GPPO Female Contact Interface Gauge
9160-116-3	GPPO Male Contact Interface Gauge

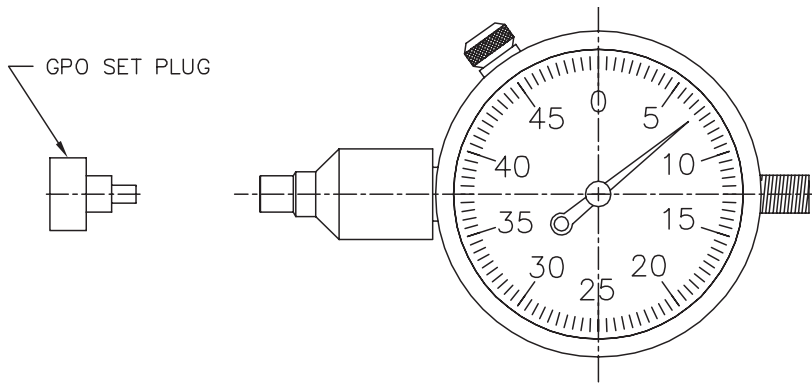

9160-107-3



9160-107-3

Press-In Punches

Catalog Number	Notes	Package Dimensions (Inches)
9001-964-0-FD	GPO Full-Detent Press-In Punch	2.50 length, Ø0.37 max
9001-964-0-LD	GPO Limited-Detent Press-In Punch	2.50 length, Ø0.37 max
9001-964-0-SB	GPO Smooth-Bore Press-In Punch	2.50 length, Ø0.37 max
B097-A99-03	GPPO Press-In Punch	2.50 length, Ø0.37 max

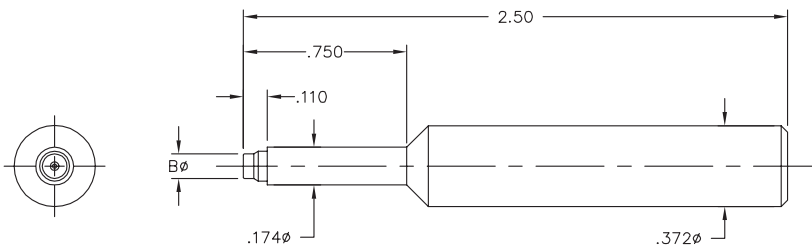

9001-964-0-FD



9001-964-0-FD

Miscellaneous

Starting and Bottoming Taps

Catalog Number	Notes	Package Dimensions (Inches)
L091-A99-01	Three Flute Plug Starting Tap for #10-48 GH3 thread	2.00 length, Ø0.15 max
L091-A99-02	Four Flute Bottoming Tap for #10-48 H2 thread	2.00 length, Ø0.15 max
L091-A99-05	Four Flute Bottoming Tap for #10-48 H2 thread	2.50 length, Ø0.23 max
L091-A99-06	Four Flute Bottoming Tap for #10-48 H2 thread	2.50 length, Ø0.23 max
B099-A99-01	Four Flute Bottom Tap for .164-64 UNS-2B thread	2.00 length, Ø0.15 max
B099-A99-02	Four Flute Bottom Tap for .164-64 UNS-2B thread	2.00 length, Ø0.15 max

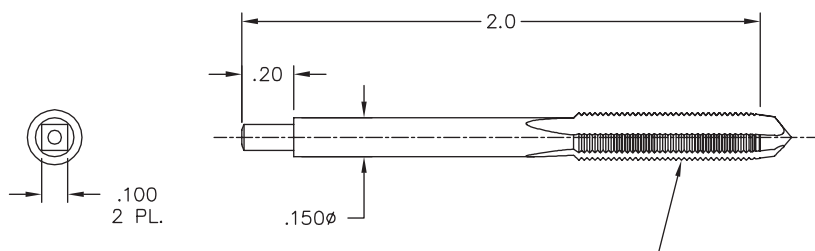

L091-A99-01



L091-A99-01

Seal Locating Tools for Thread-In Shrouds

Catalog Number	Notes	Package Dimensions (Inches)
L096-A99-04	Shim Gauge .006 thick with .0235 slot	0.25 length, 0.19 width, 0.007 height
L096-A99-03	Shim Gauge .010 thick with .0235 slot	0.25 length, 0.19 width, 0.01 height

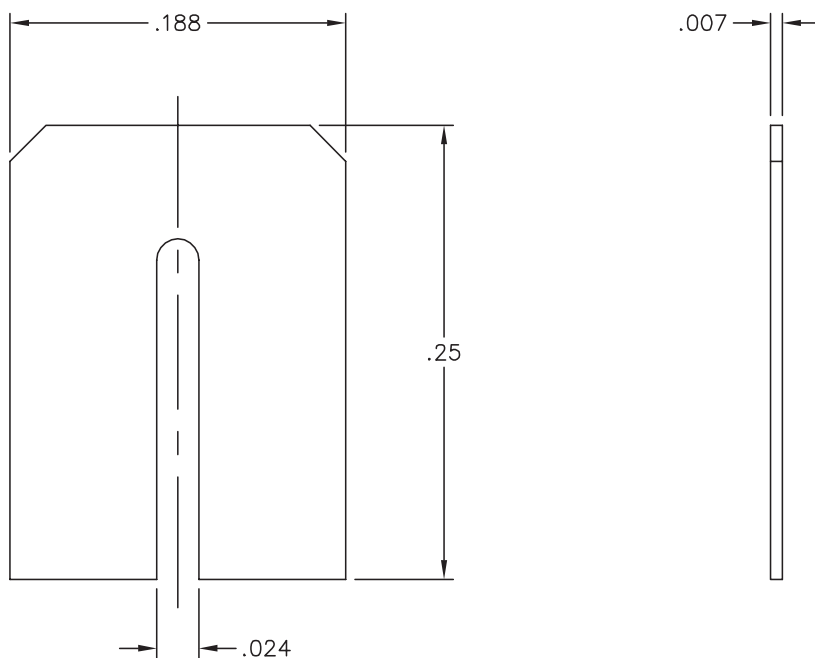

L096-A99-04



L096-A99-04



Technical Guide

Test Capabilities

Corning's commitment to quality has made it a leader in the connector industry. Mechanical and electrical quality is verified in every lot of connectors via the internal standard testing procedures. These standard tests include, but are not limited to:

- Visual and mechanical inspection
- Dielectric withstanding voltage (DWV)
- Hermetic seal
- Leakage
- Force to engage/disengage
- Mating characteristics
- Permeability
- Insulation resistance
- Voltage standing wave ratio (VSWR)

All tests listed above are standard and part of groups A and B testing, per MIL-PRF-39012.

Expanded testing may be obtained by requesting ATP-2000. This test includes all of ATP-1000, as well as 100 percent thermal shock testing and 100 percent visual and mechanical inspection.

Since many Corning connectors are utilized in military or aerospace applications, custom test inspection documents (TIDs) are created on a regular basis for those requiring heightened or special testing. The TIDs verify compliance to the customers' requests and/or their submitted source-controlled documents (SCDs).

Whether you are looking for a commercial, off-the-shelf part, or need extensive qualification and acceptance testing, Corning can assure you and your customers that the parts you need are the parts you receive.

Custom Packaging

Corning is a leader in designing custom solutions, whether it is with specialty connectors or for special packaging/delivery requirements. Our in-house surface-mount device (SMD) tape and reel capabilities provide a turnkey solution with a quick turnaround, while maintaining compliance with EIA-481C.

Other Packaging Options

In addition to tape and reel, we offer custom packaging that can be incorporated into various programs for quick and efficient distribution to the manufacturing floor. For example, highly compact waffle packs are designed to accommodate G3PO™ blind mate interconnects in excess of 200 pieces in trays as small as 2 x 2 x 0.5 in. Available options also include color coding, electrostatic discharge (ESD), and bar code labeling.

Introduction

Corning provides push-on interconnect solutions that are designed for blind mating and electrical performance when fully mated or mechanically misaligned. The push-on interface features ease of mating along with a high-reliability electro-mechanical connection. This solution enables high-density system flexibility while maintaining functionality from DC to 65 GHz.

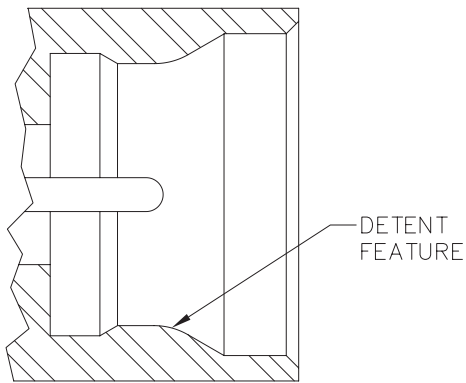

Figure 1 – Full Detent

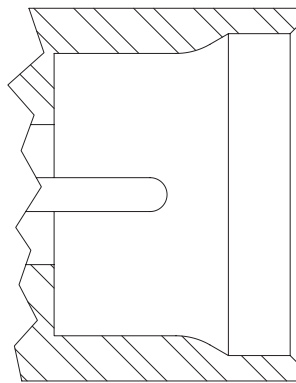

Figure 2 – Smooth Bore

Detent features are provided to retain the push-on connectors in the mated condition. Different levels of engage and disengage forces are accomplished by the stepped feature on the inside of the shroud housing. Figure 1 shows the full detent interfaces are also available with reduced engage and disengage forces. Figure 2 shows the smooth bore interface which has the lowest mating forces (no stepped detent feature).

Module-to-module and board-to-board applications typically use a three-connector system. One blind-mate interconnect (BMI), also known as a bullet, is mated between a full detent and a smooth bore shroud. The full detent interface retains the BMI yet allows radial misalignment. The smooth bore interface allows misalignment in both radial and axial orientations.

Mechanical misalignment is the result of multiple component systems and the associated positional tolerances. Axial misalignment is the offset distance between the shroud and BMI reference planes. For most connectors, coplanar reference planes provide the best electrical performance. Corning can design connectors for optimal performance with a preset amount of axial misalignment. This enables good electrical performance with movement in both axial directions. Radial misalignment is the distance between the centerlines of the mated shroud connectors. Also known as gimbaling, radial misalignment is directly related to the BMI length.

Introduction

Figure 3 shows the BMI axially misaligned with an offset distance between the shroud and BMI reference planes. The fully mated condition (no offset) is ideal for best electrical performance on most connectors.

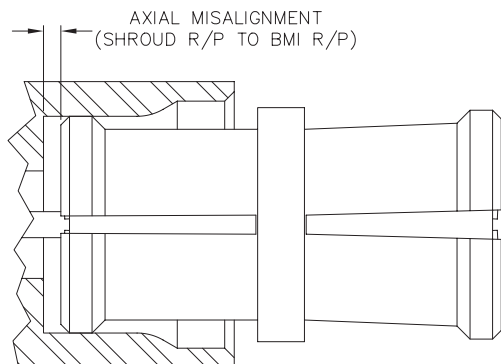

Figure 3 – Axial Misalignment

Figure 4 shows the BMI mated between two connectors that are radially misaligned from centerline to centerline. The amount of radial misalignment is dependent upon the length and angle of the BMI. The GPO® standard angle of three degrees is mainly a function of the allowable connector housing movement.

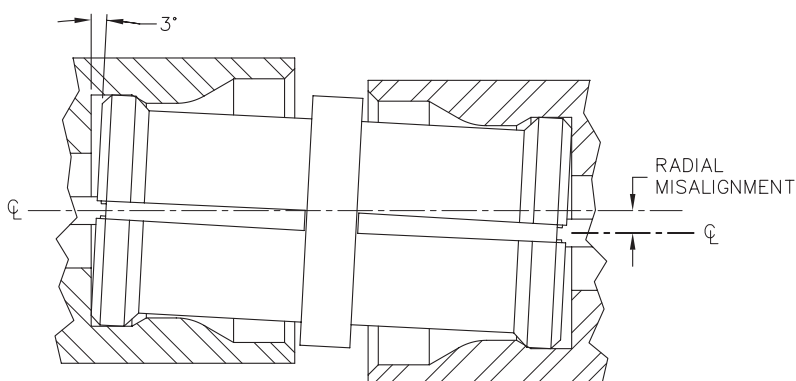

Figure 4 – Radial Misalignment

Various configurations are available such as blind mate interconnects, printed circuit board connectors, cable connectors, and hermetic panel connectors. The GPO connectors are also functionally compliant with the SMP interface of MIL-PRF-31031. Performance and reliability make Corning the push-on connector of choice.

1.0 Materials and Finishes

Tables 1A, 1B, and 1C show the standard materials and finishes used to manufacture Corning push-on connectors. This includes various configurations across our GPO®, GPPO®, G3PO™, and G4PO™ product families.

Table 1A – Metal Materials

Material	Specification
BeCu (beryllium copper)	ASTM B 196 and/or ASTM B 197
Brass	ASTM B 36, B121, B16, B16M
Stainless steel	ASTM A484/A582 or A555/581
Iron-nickel-cobalt	ASTM F-15

Table 1B – Metal Finishes

Finish	Specification
Gold (75u in. Typ)	ASTM-B488 Type 1, Class 1.25
Nickel (1007 in. Typ)	SAE AMS-QQ-N-290

Table 1C – Dielectric Materials

Material	Specification
Virgin PTFE fluorocarbon	ASTM D 1710 and ASTM D 1457
Polyamide-imide	ASTM D5204 Group 2 Class 1
Glass	Corning 7070 or Equivalent

The characteristics of the above materials enable the standard storage and operating temperature range of -65 to +165 degrees Celsius.

2.0 GPO®

2.1 GPO® Detents – Full, Limited, and Smooth Bore

Table 2 shows the available GPO detents, typical engage/disengage forces, and mating cycles.

Table 2 – GPO Detent Forces and Mating Cycles

Detent	GPO		
	Engage*	Disengage*	Cycles (Minutes)
Full	7.0	9.0	100
Limited	5.0	7.0	500
Smooth Bore	3.0	0.5	1,000

*The engage/disengage force values (shown in pounds) are typical and based upon actual data

2.2 GPO Axial Misalignment

Figure 5 shows the GPO VSWR electrical performance vs. frequency and axial misalignment.

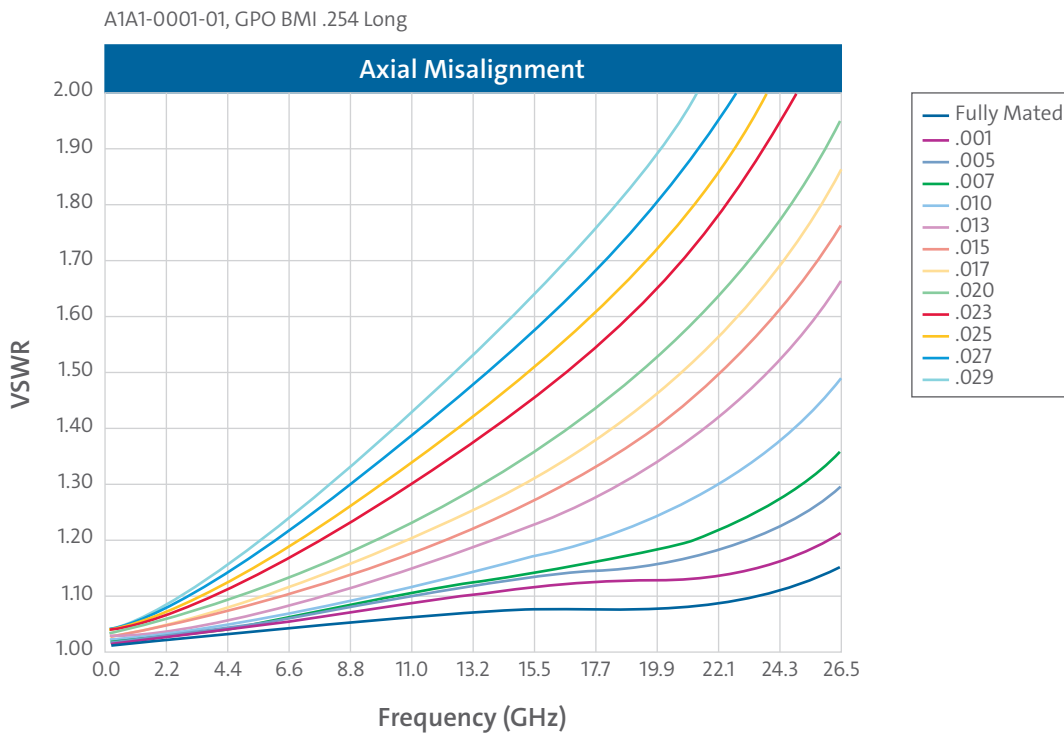

Figure 5 – GPO Axial Misalignment Performance

2.0 GPO®

2.3 GPO® Radial Misalignment

Figure 6 shows the GPO VSWR electrical performance vs. frequency and radial misalignment.

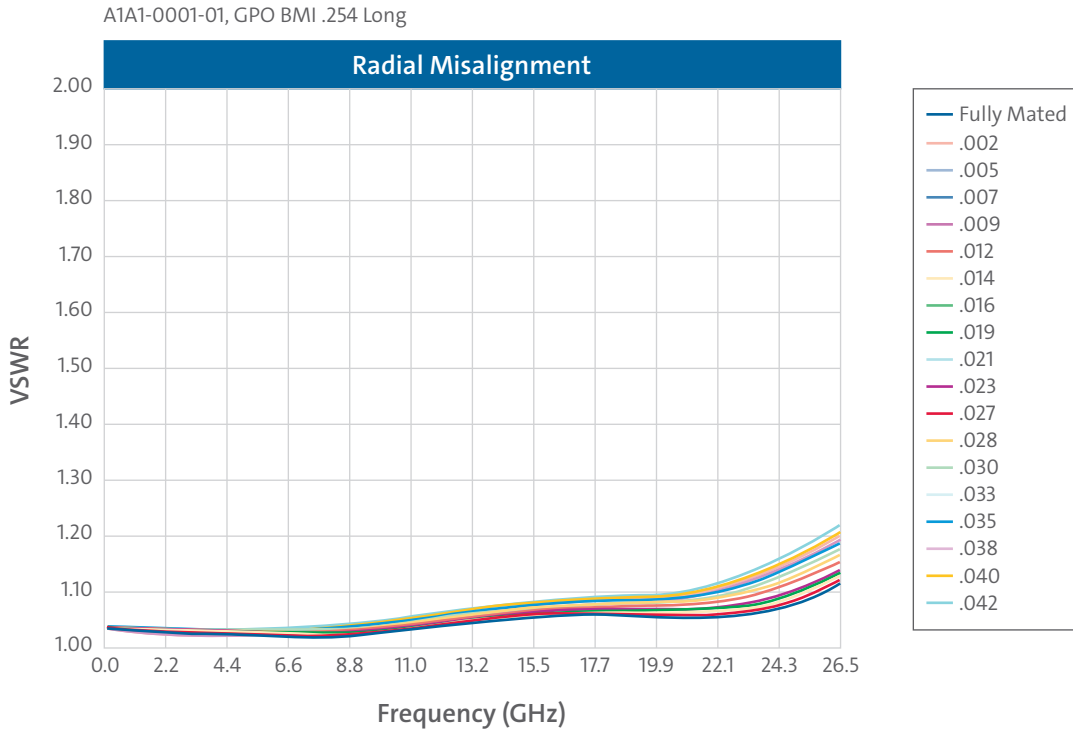

Figure 6 – GPO Radial Misalignment Performance

2.4 GPO VSWR and Insertion Loss



Figure 7 – GPO BMI A1A1-0001-01

2.0 GPO®

2.4 GPO® VSWR and Insertion Loss

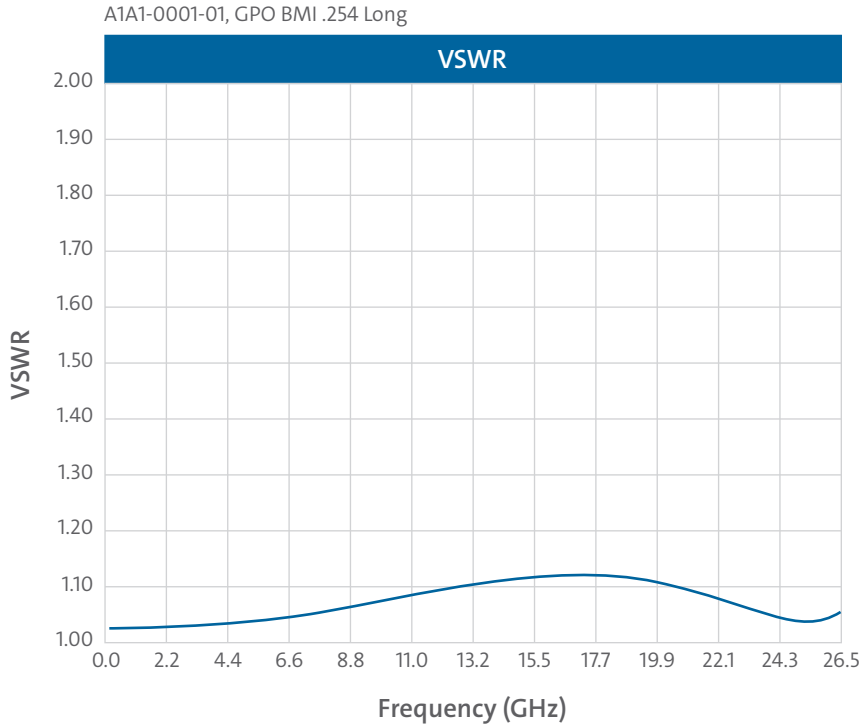

Figure 7A – GPO BMI VSWR Performance

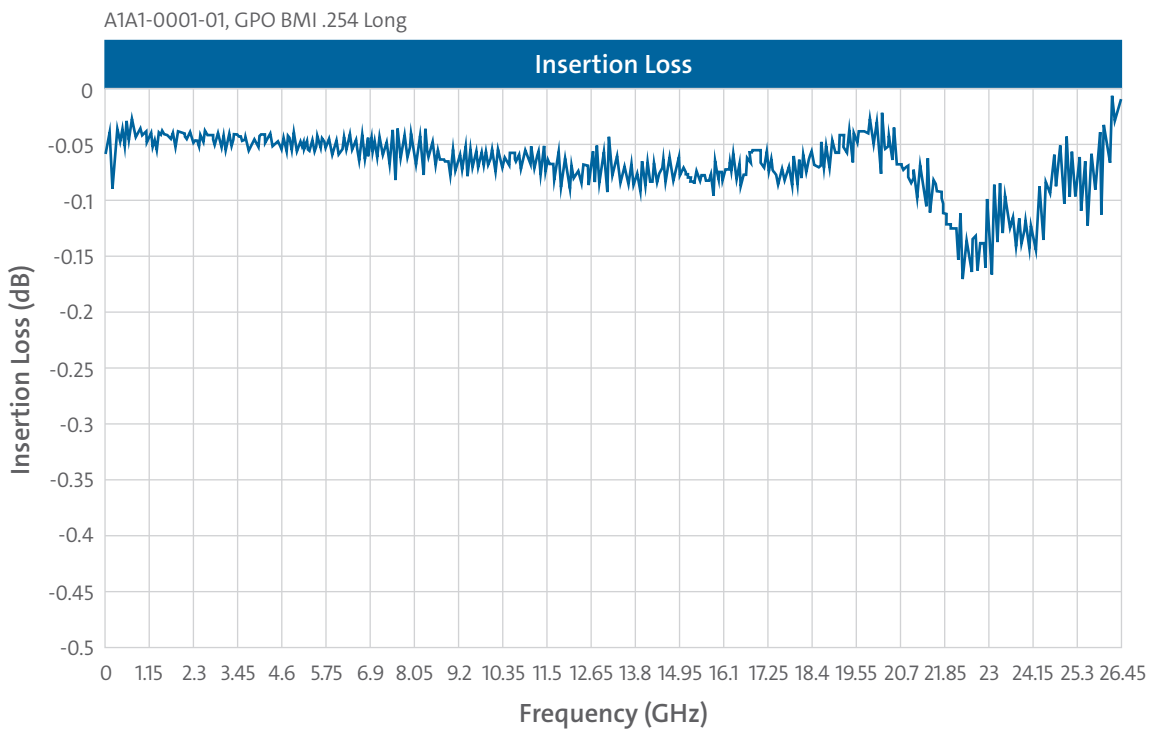

Figure 7B – GPO BMI Insertion Loss Performance

2.0 GPO®

2.4 GPO® VSWR and Insertion Loss

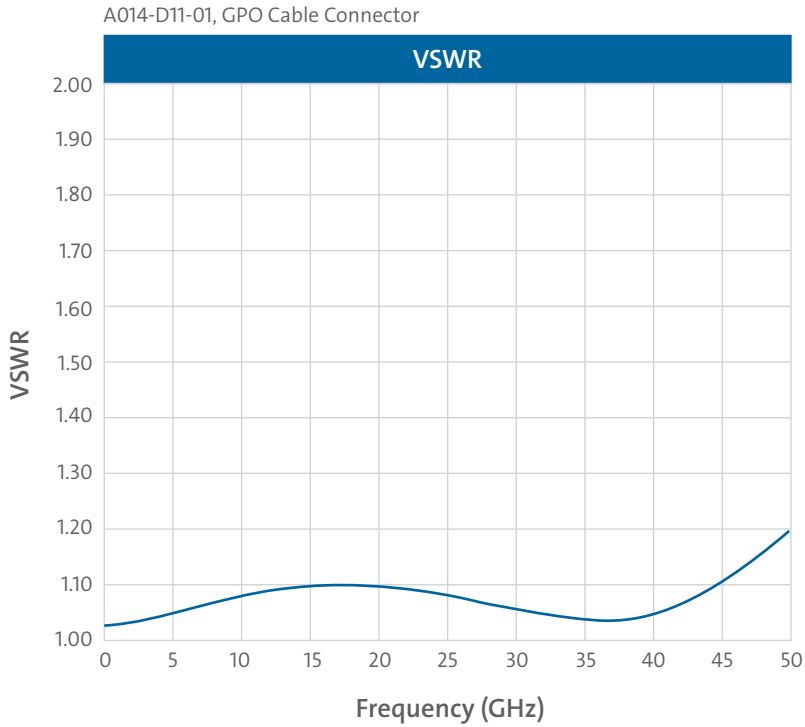

Figure 8 – GPO Cable Connector VSWR Performance



Figure 8A – GPO Cable Connector
A014-D11-01

3.0 GPPO®

3.1 GPPO® Detents – Full and Smooth Bore

Table 3 shows the available GPPO detents, typical engage/disengage forces, and mating cycles.

Table 3 – GPPO Detent Forces and Mating Cycles

Detent	GPPO		
	Engage*	Disengage*	Cycles (Minutes)
Full	4.5	6.5	100
Smooth Bore	2.5	1.5	500

*The engage/disengage force values (shown in pounds) are typical and based upon actual data

3.2 GPPO Axial Misalignment

Figure 9 shows the GPPO VSWR electrical performance vs. frequency and axial misalignment.

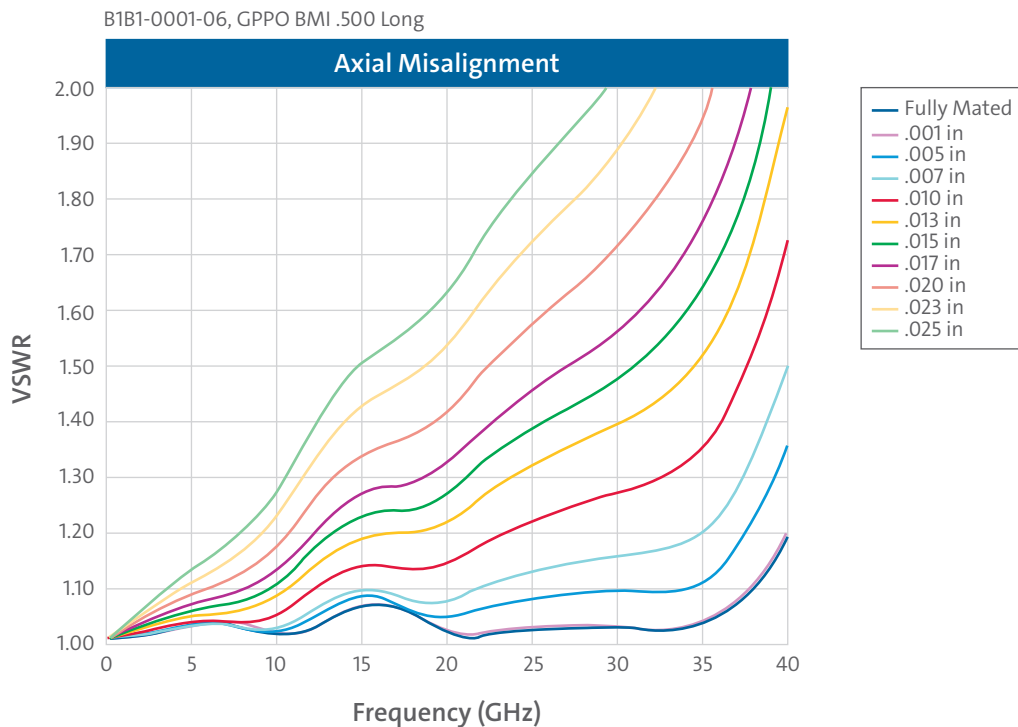

Figure 9 – GPPO Axial Misalignment Performance

3.0 GPPO®

3.3 GPPO® Radial Misalignment

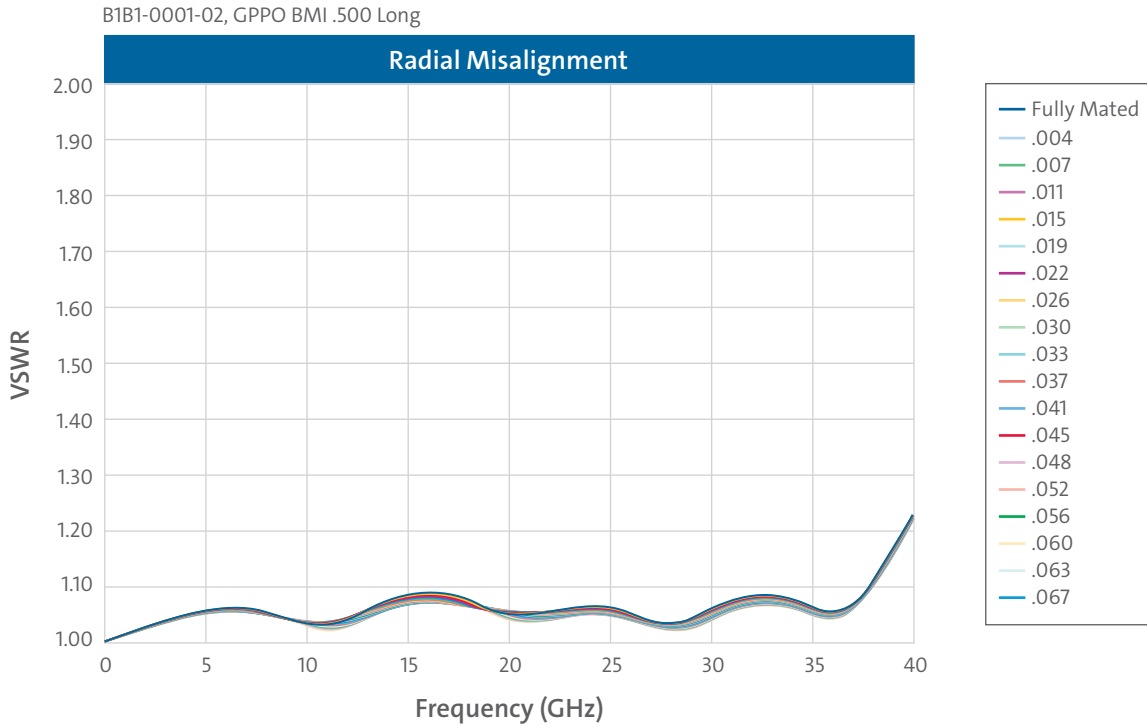

Figure 10 – GPPO Radial Misalignment Performance

3.4 GPPO VSWR and Insertion Loss



Figure 11 – GPPO BMI B1B1-0001-01

3.0 GPPO®

3.4 GPPO® VSWR and Insertion Loss

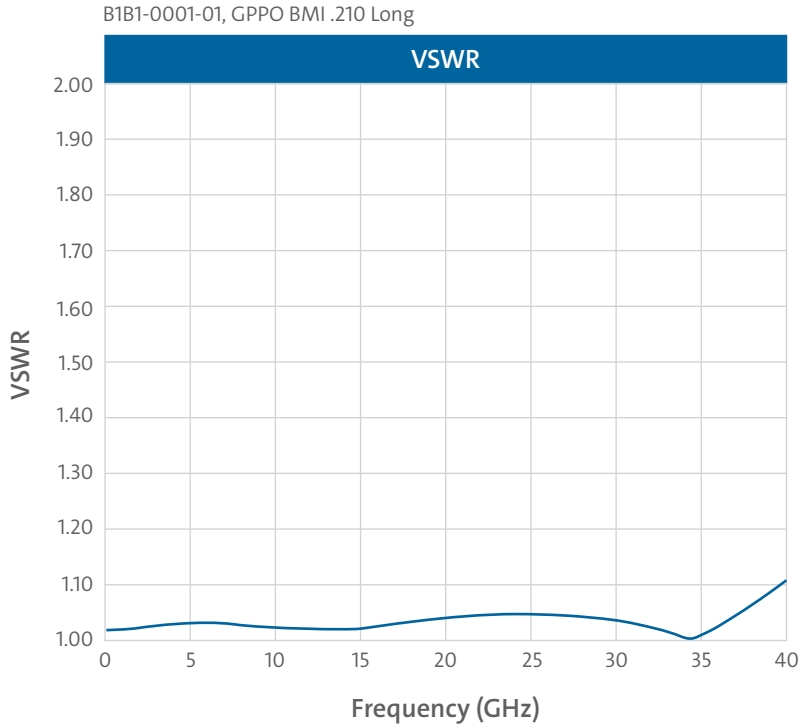

Figure 11A – GPPO BMI VSWR Performance

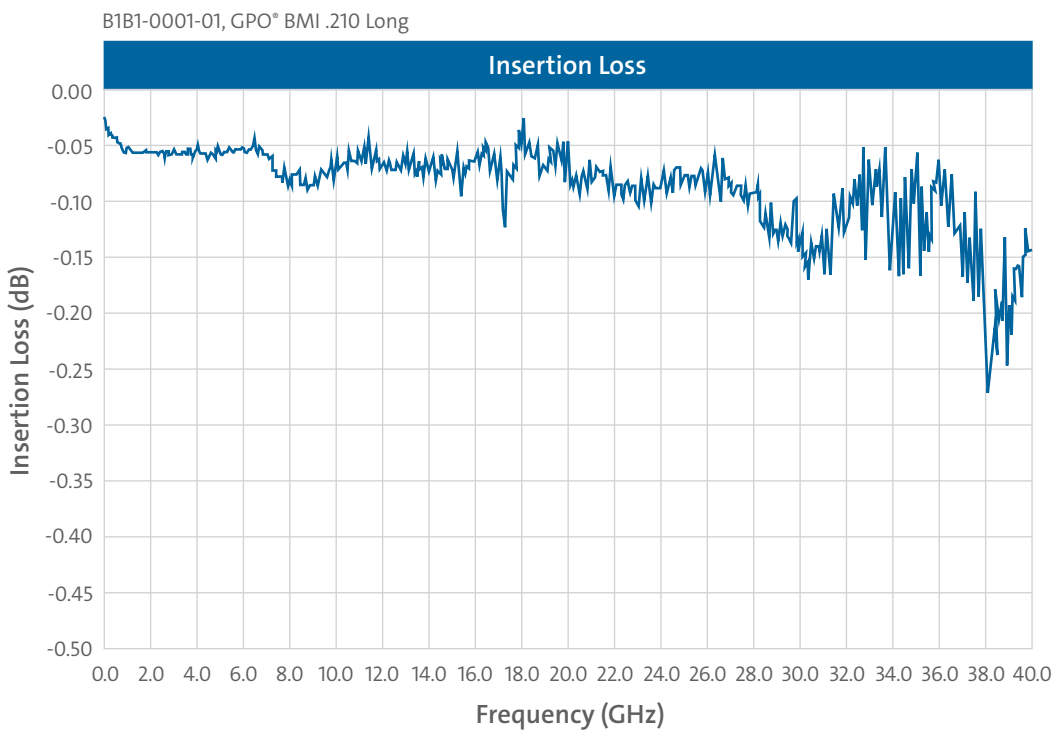

Figure 11B – GPPO BMI Insertion Loss Performance

3.0 GPPO®

3.4 GPPO® VSWR and Insertion Loss

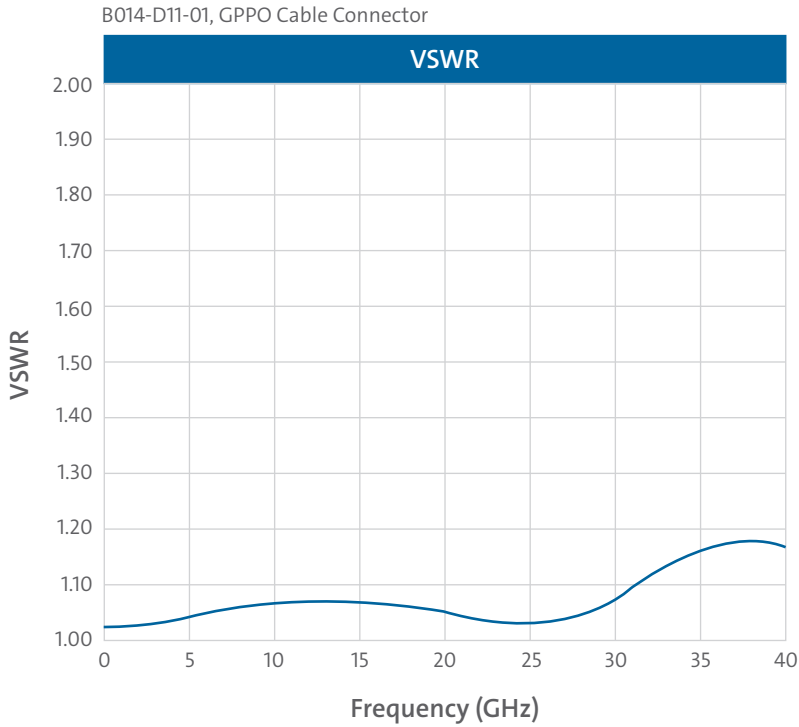

Figure 12 – GPPO Cable Connector VSWR Performance



Figure 12A – GPPO Cable Connector B014-D11-01

4.0 G3PO™

4.1 G3PO™ Detents – Full and Smooth Bore

Table 4 shows the available G3PO detents, typical engage/disengage forces, and mating cycles.

Table 4 – G3PO Detent Forces and Mating Cycles

Detent	G3PO		
	Engage*	Disengage*	Cycles (Minutes)
Full	2.5	4.5	100
Smooth Bore	1.2	1.0	500

*The engage/disengage force values (shown in pounds) are typical and based upon actual data

4.2 G3PO Axial Misalignment

Figure 13 shows the G3PO VSWR electrical performance vs. frequency and axial misalignment.

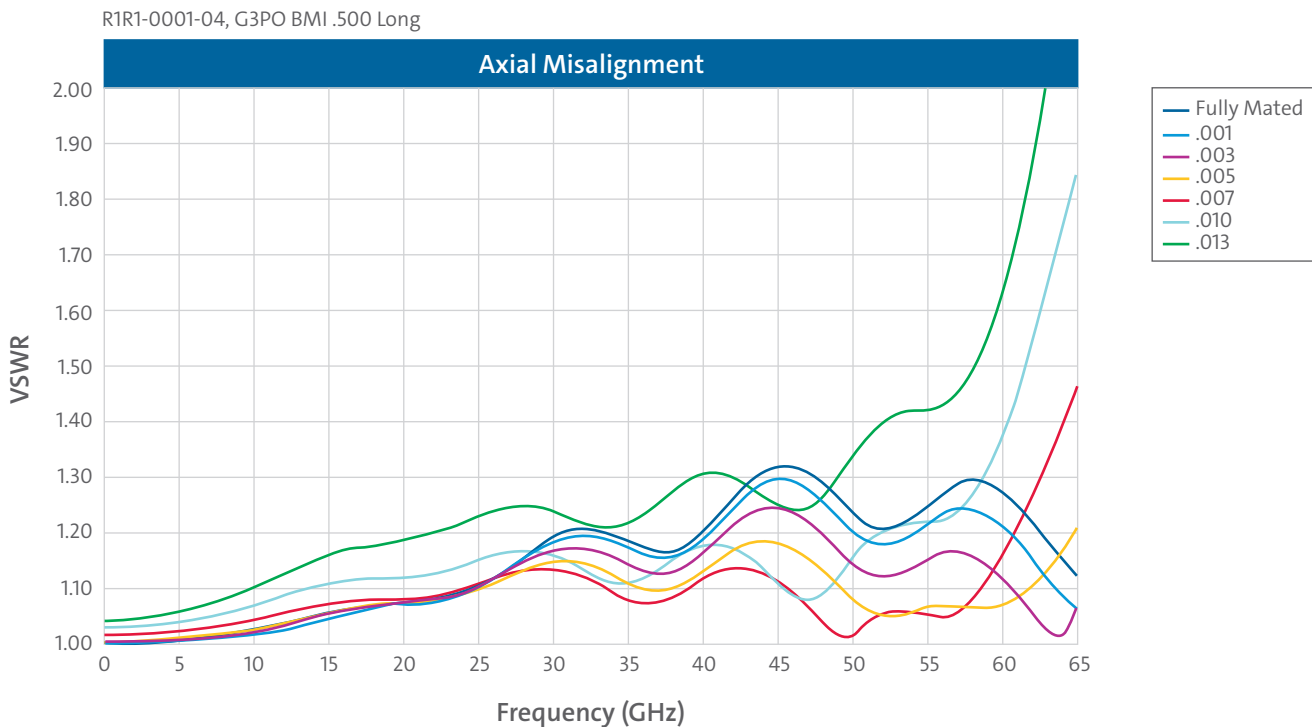

Figure 13 – G3PO Axial Misalignment Performance

4.0 G3PO™

4.3 G3PO™ Radial Misalignment

Figure 14 shows the G3PO VSWR electrical performance vs. frequency and radial misalignment.

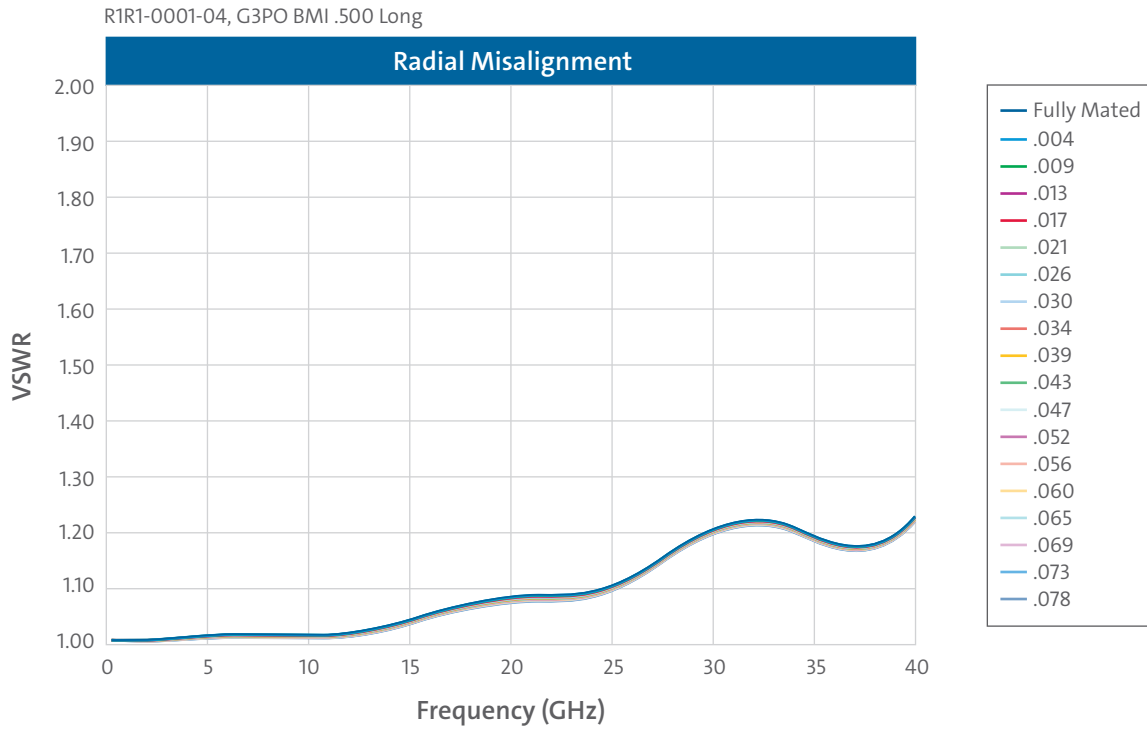

Figure 14 – G3PO Radial Misalignment Performance

4.4 G3PO VSWR and Insertion Loss



Figure 15 – G3PO BMI R1R1-0001-01

4.0 G3PO™

4.4 G3PO™ VSWR and Insertion Loss

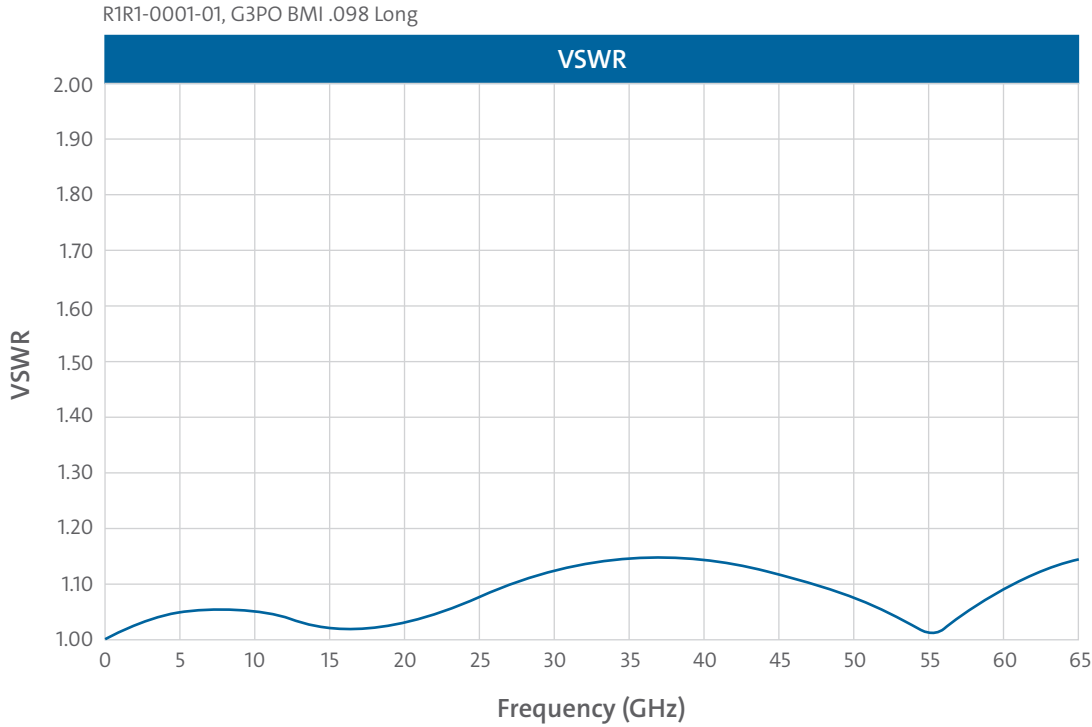

Figure 15A – G3PO BMI VSWR Performance

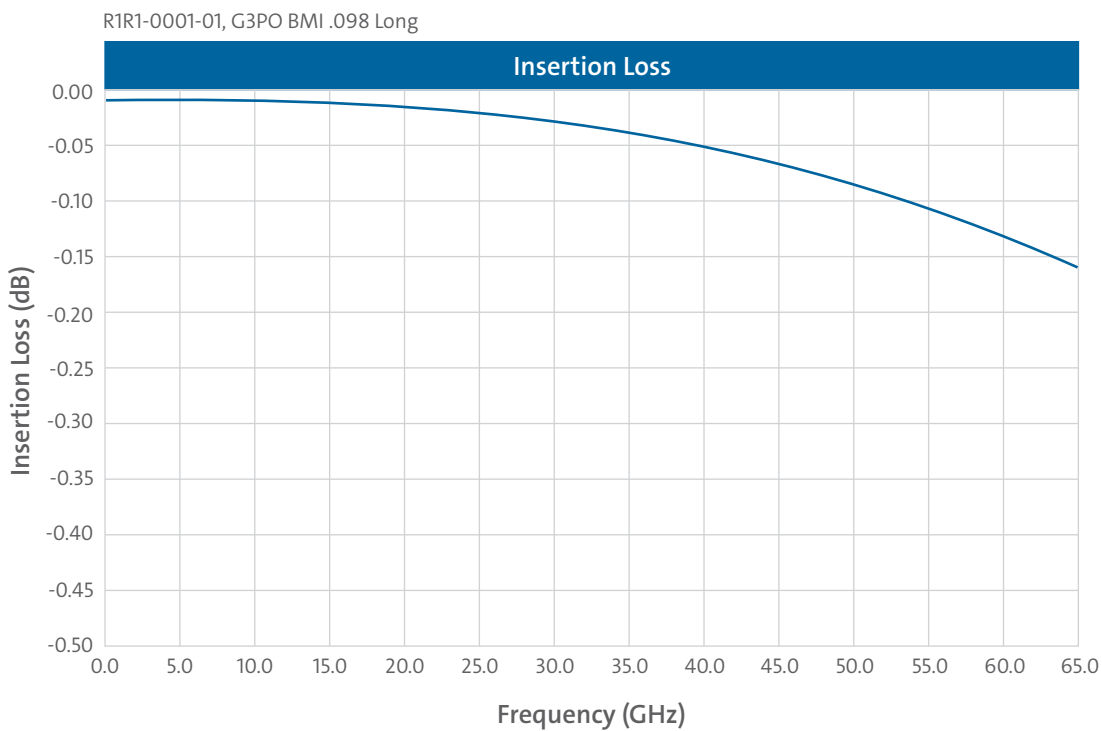

Figure 15B – G3PO BMI Insertion Loss Performance

4.0 G3PO™

4.4 G3PO™ VSWR and Insertion Loss

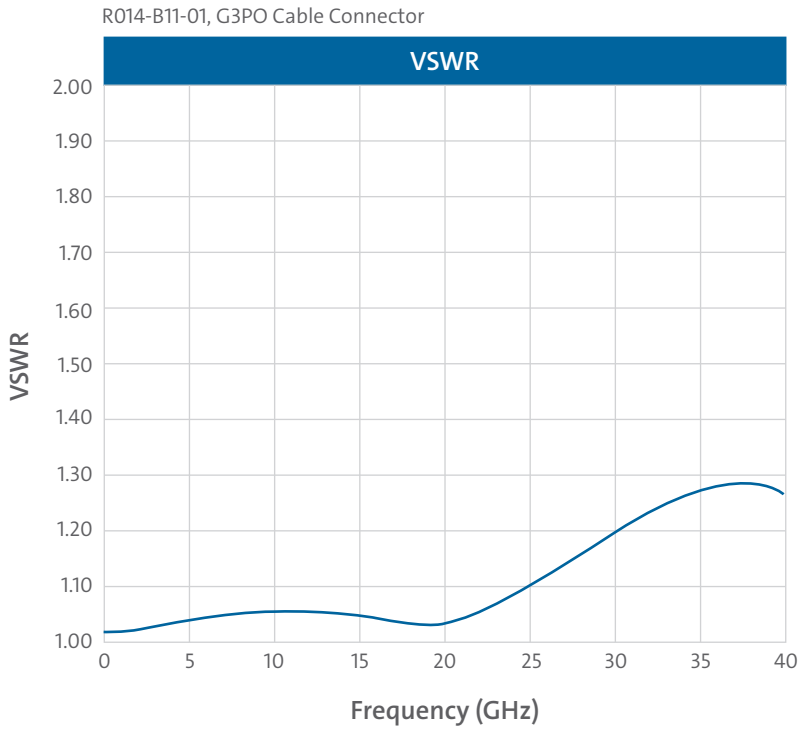

Figure 16- G3PO Cable Connector VSWR Performance



Figure 16A – G3PO Cable Connector R014-B11-01

5.0 G4PO™

5.1 G4PO™ Detents – Full and Smooth Bore

Table 5 shows the available G4PO detents, typical engage/disengage forces, and mating cycles.

Table 5 – G4PO Detent Forces and Mating Cycles

Detent	G4PO		
	Engage*	Disengage*	Cycles (Minutes)
Full	.65	2.2	100
Smooth Bore	.20	.15	500

*The engage/disengage force values (shown in pounds) are typical and based upon actual data

5.2 G4PO VSWR

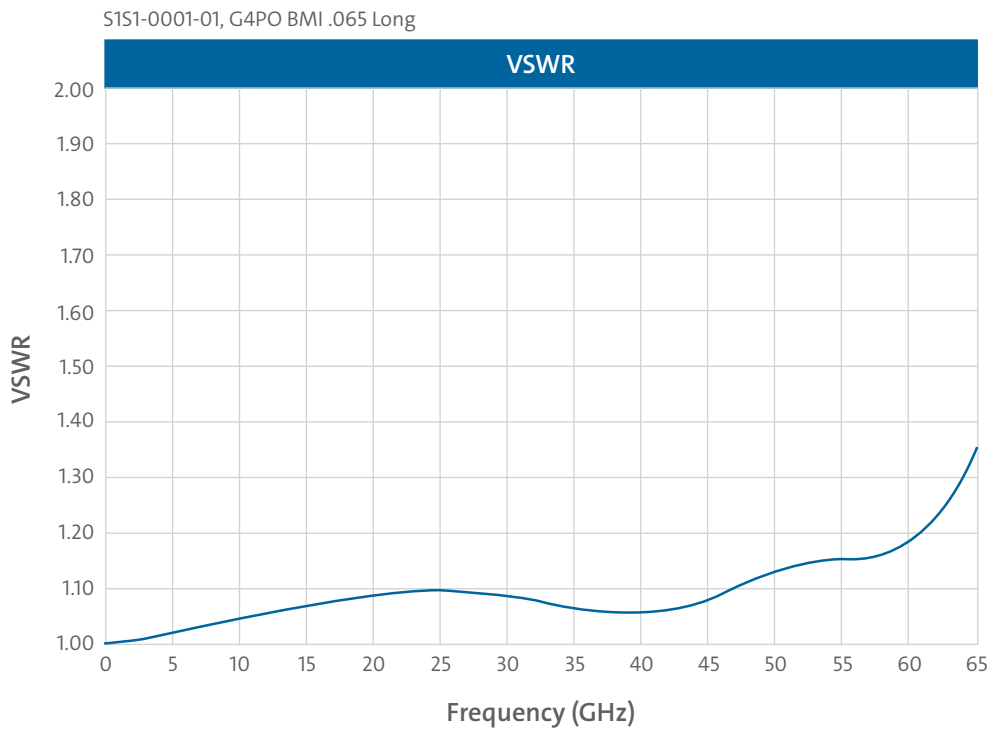

Figure 17 – G4PO BMI VSWR Performance



Figure 17A – G4PO BMI S151-0001-01

6.0 Electrical – GPO®, GPPO®, G3PO™, and G4PO™

6.1 General Electrical Specifications

Table 6 – GPO®, GPPO®, G3PO™, and G4PO™ General Electrical Specifications

Parameter	GPO	GPPO	G3PO	G4PO
Dielectric Withstanding Voltage (DWV)	500 V _{rms}	325 V _{rms}	250 V _{rms}	250 V _{rms}
Insulation Resistance (IR)	5000 mohms @ 500 VDC	5000 mohms @ 500 VDC	3500 mohms @ 100 VDC	3500 mohms @ 100 VDC
RF High Pot. @ 5 MHz	325 V _{rms}	200 V _{rms}	150 V _{rms}	150 V _{rms}
Corona Level @ 70,000 ft	190 V _{rms}	125 V _{rms}	100 V _{rms}	100 V _{rms}
Center Conductor Contact Resistance	6.0 mohms max	6.0 mohms max	6.0 mohms max	6.0 mohms max

6.2 Average Power Handling

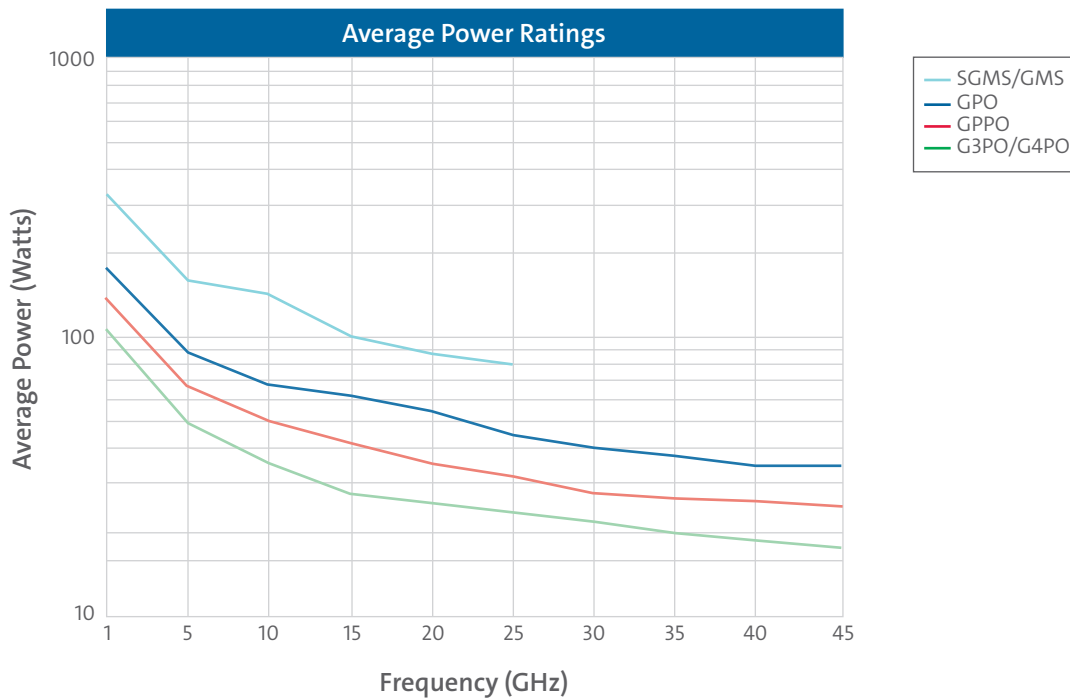

Figure 18 – GPO, GPPO, G3PO and G4PO Average Power Handling

6.0 Electrical – GPO®, GPPO®, G3PO™, and G4PO™

6.3 Temperature and Altitude Derating

Table 7 – Typical Temperature and Altitude Derating Factors

Temperature Degrees Celsius	Derating Factor	Altitude x 1000 ft	Derating Factor
0	1.2	0	1.0
40	1.0	20	0.8
80	0.8	30	0.7
120	0.6	40	0.6
160	0.4	50	0.5
200	0.2	60	0.4
240	0.05	70	0.3

6.4 VSWR Derating

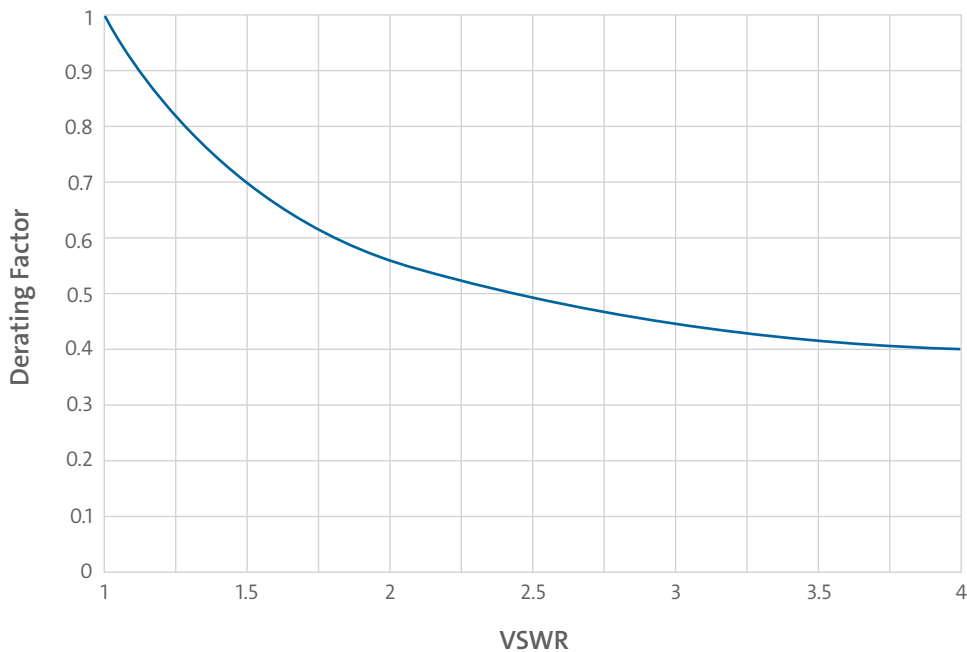

Figure 19 – Typical VSWR Derating Factors

7.0 Board-to-Board Tolerance Analysis

7.1 GPO® Minimum Tolerance Analysis

Figure 20 shows the minimum GPO® board-to-board tolerance analysis using a surface-mount configuration. The BMI length and associated gap are dependent on the board-to-board spacing, shroud reference plane (R/P), and solder thickness.

Determine the shroud R/P to shroud R/P:

.258 ± .005	Board-to-board
-.010 ± .001	Shroud R/P
-.010 ± .001	Shroud R/P
-.002 ± .001	Solder thickness
-.002 ± .001	Solder thickness

.234 ± .009 Shroud R/P to R/P (-in)

The minimum shroud R/P-to-R/P spacing is therefore $.234 - .009 = .225$ -in. This dimension is also the maximum BMI length. This spacing ensures that the BMI does not bottom out between the shroud reference planes. The nominal BMI length is the minimum R/P-to-R/P spacing minus the BMI length tolerance (.001-in). The nominal BMI length is therefore $.225 - .001 = .224$ -in.

Next determine the gap between the smooth bore shroud R/P and the BMI as follows:

.234 ± .009	Shroud R/P to shroud R/P
-.224 ± .001	BMI length

.010 ± .010 Gap (-in)

The tolerance analysis shows that the BMI can be flush (.010 - .010) to .020 (.010 + .010) away from the smooth bore shroud R/P. The gap tolerance should be minimized whenever possible to ensure optimal electrical performance.

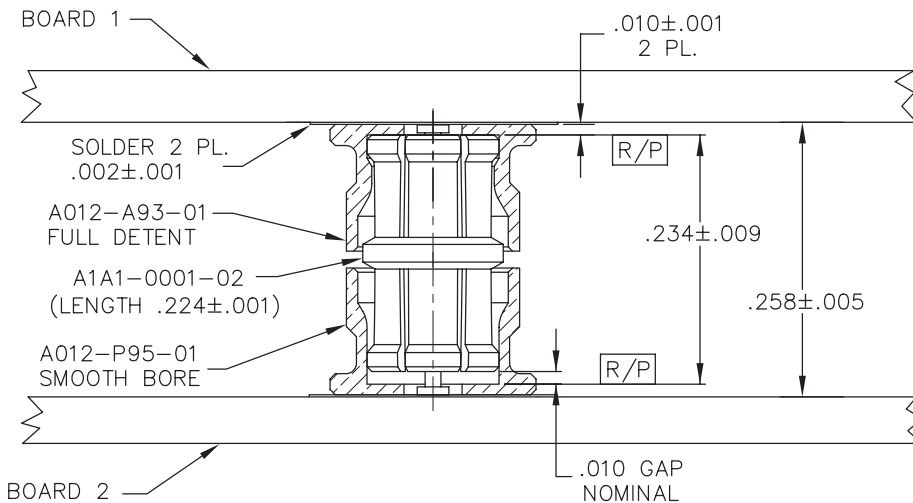

Figure 20 – GPO Minimum Board-to-Board Tolerance Analysis

7.0 Board-to-Board Tolerance Analysis

7.2 GPPO® Tolerance Analysis

Figure 21 shows a typical GPPO® board-to-board tolerance analysis using a surface-mount configuration. The BMI length and associated gap are dependent on the board-to-board spacing, shroud reference plane (R/P), and solder thickness.

Determine the shroud R/P to shroud R/P:

$.360 \pm .005$	Board-to-board
$-.067 \pm .002$	Shroud R/P
$-.067 \pm .002$	Shroud R/P
$-.002 \pm .001$	Solder thickness
$-.002 \pm .001$	Solder thickness

$.222 \pm .011$ Shroud R/P to R/P (-in)

The minimum shroud R/P-to-R/P spacing is therefore $.222 - .011 = .211$ -in. This dimension is also the maximum BMI length. This spacing ensures that the BMI does not bottom out between the shroud reference planes. The nominal BMI length is the minimum R/P-to-R/P spacing minus the BMI length tolerance ($.001$ -in). The nominal BMI length is therefore $.211 - .001 = .210$ -in.

Next determine the gap between the smooth bore shroud R/P and the BMI as follows:

$.222 \pm .011$	Shroud R/P to shroud R/P
$-.210 \pm .001$	BMI length

$.012 \pm .012$ Gap (-in)

The tolerance analysis shows that the BMI can be flush ($.012 - .012$) to $.024$ ($.012 + .012$) away from the smooth bore shroud R/P. The gap tolerance should be minimized whenever possible to ensure optimal electrical performance.

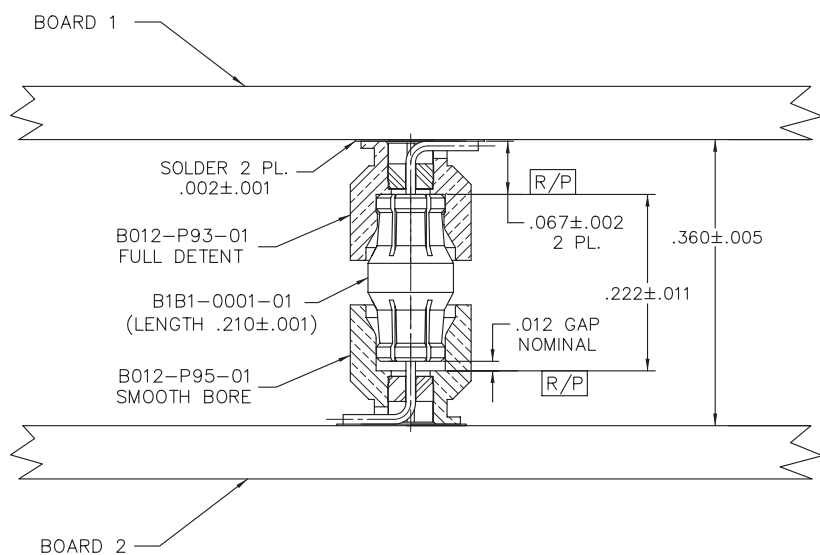

Figure 21 – GPPO Board-to-Board Tolerance Analysis

7.0 Board-to-Board Tolerance Analysis

7.3 GPPO® Minimum Tolerance Analysis

Figure 22 shows a typical GPPO® board-to-board tolerance analysis using a surface-mount configuration. The BMI length and associated gap are dependent on the board-to-board spacing, shroud reference plane (R/P), and solder thickness.

Determine the shroud R/P to shroud R/P:

.196 ± .005	Board-to-board
-.008 ± .001	Shroud R/P
-.008 ± .001	Shroud R/P
-.002 ± .001	Solder thickness
-.002 ± .001	Solder thickness

.176 ± .009 Shroud R/P to R/P (-in)

The minimum shroud R/P-to-R/P spacing is therefore $.176 - .009 = .167$ -in. This dimension is also the maximum BMI length. This spacing ensures that the BMI does not bottom out between the shroud reference planes. The nominal BMI length is the minimum R/P-to-R/P spacing minus the BMI length tolerance (.001-in). The nominal BMI length is therefore $.167 - .001 = .166$ -in.

Next determine the gap between the smooth bore shroud R/P and the BMI as follows:

.176 ± .009	Shroud R/P to shroud R/P
-.166 ± .001	BMI length

.010 ± .010 Gap (-in)

The tolerance analysis shows that the BMI can be flush (.010 - .010) to .020 (.010 + .010) away from the smooth bore shroud R/P. The gap tolerance should be minimized whenever possible to ensure optimal electrical performance.

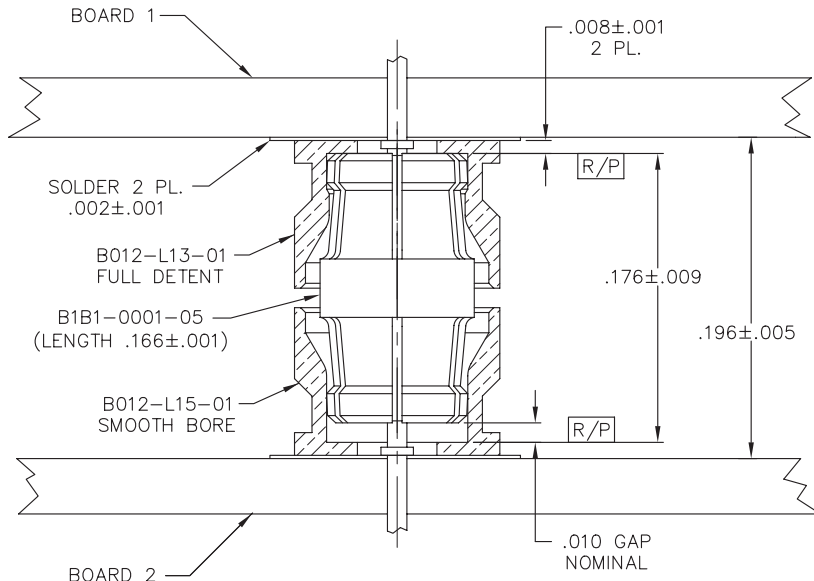

Figure 22 – GPPO Minimum Board-to-Board Tolerance Analysis

7.0 Board-to-Board Tolerance Analysis

7.4 G3PO™ Tolerance Analysis

Figure 23 shows a typical G3PO™ board-to-board tolerance analysis using a surface-mount configuration. The BMI length and associated gap are dependent on the board-to-board spacing, shroud reference plane (R/P), and solder thickness.

Determine the shroud R/P to shroud R/P:

.1485 ± .002	Board-to-board
-.020 ± .001	Shroud R/P
-.020 ± .001	Shroud R/P
-.002 ± .001	Solder thickness
-.002 ± .001	Solder thickness

.1045 ± .006 Shroud R/P to R/P (-in)

The minimum shroud R/P-to-R/P spacing is therefore $.1045 - .006 = .0985$ -in. This dimension is also the maximum BMI length. This spacing ensures that the BMI does not bottom out between the shroud reference planes. The nominal BMI length is the minimum R/P-to-R/P spacing minus the BMI length tolerance ($.0005$ -in). The nominal BMI length is therefore $.0985 - .0005 = .098$ -in.

Next determine the gap between the smooth bore shroud R/P and the BMI as follows:

.1045 ± .006	Shroud R/P to shroud R/P
-.098 ± .0005	BMI length

.0065 ± .0065 Gap (-in)

The tolerance analysis shows that the BMI can be flush ($.0065 - .0065$) to $.013$ ($.0065 + .0065$) away from the smooth bore shroud R/P. The gap tolerance should be minimized whenever possible to ensure optimal electrical performance.

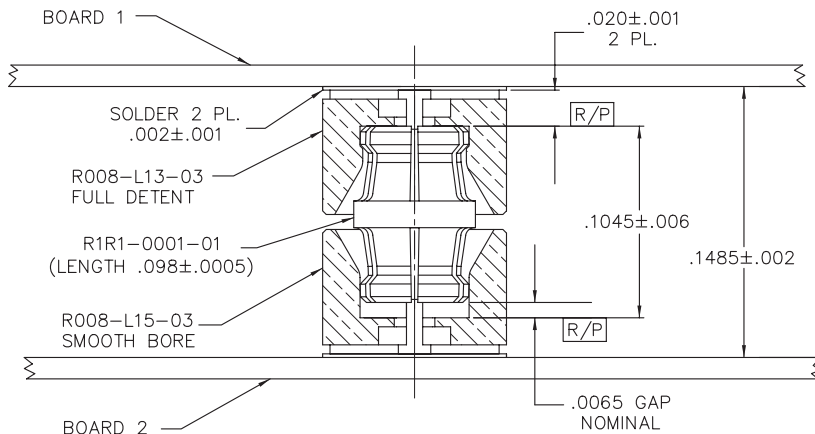

Figure 23 – G3PO Board-to-Board Tolerance Analysis

7.0 Board-to-Board Tolerance Analysis

7.5 G4PO™ Tolerance Analysis

Figure 24 shows a typical G4PO™ board-to-board tolerance analysis using a surface-mount configuration. The BMI length and associated gap are dependent on the board-to-board spacing, shroud reference plane (R/P), and solder thickness.

Determine the shroud R/P to shroud R/P:

$.122 \pm .0015$	Board-to-board
$-.0235 \pm .001$	Shroud R/P
$-.0235 \pm .001$	Shroud R/P
$-.002 \pm .001$	Solder thickness
$-.002 \pm .001$	Solder thickness

$.071 \pm .0055$ Shroud R/P to R/P (-in)

The minimum shroud R/P-to-R/P spacing is therefore $.071 - .0055 = .0655$ -in. This dimension is also the maximum BMI length. This spacing ensures that the BMI does not bottom out between the shroud reference planes. The nominal BMI length is the minimum R/P-to-R/P spacing minus the BMI length tolerance ($.0005$ -in). The nominal BMI length is therefore $.0655 - .0005 = .065$ -in.

Next determine the gap between the smooth bore shroud R/P and the BMI as follows:

$.071 \pm .0055$	Shroud R/P to shroud R/P
$-.065 \pm .0005$	BMI length

$.006 \pm .006$ Gap (-in)

The tolerance analysis shows that the BMI can be flush ($.006 - .006$) to $.012$ ($.006 + .006$) away from the smooth bore shroud R/P. The gap tolerance should be minimized whenever possible to ensure optimal electrical performance.

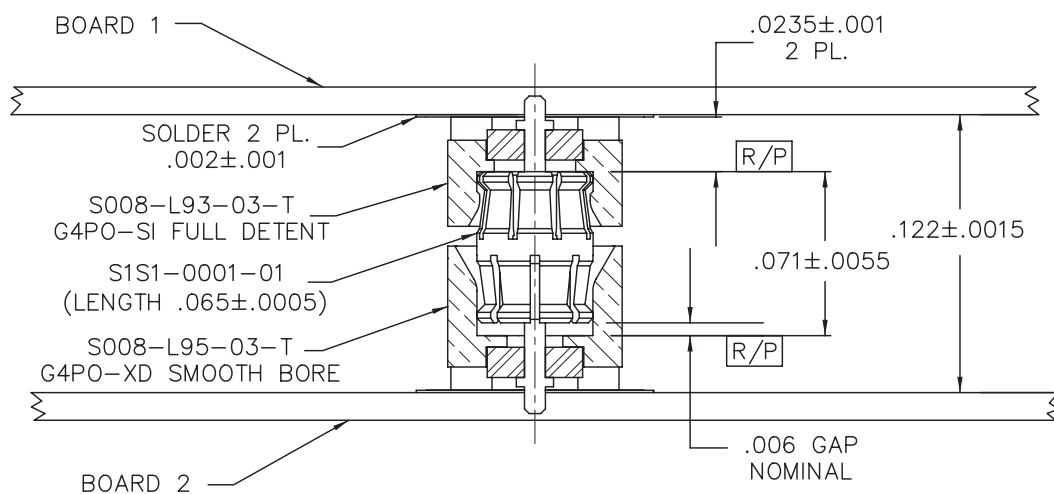

Figure 24 – G4PO Board-to-Board Tolerance Analysis

Are you Corning connected?

1-828-901-5000 (International)

800-743-2675 (United States and Canada)

ccsamericas@corning.com

www.corning.com/microwave

Corning Representative: _____

Distribution Representative: _____

Phone Number: _____

Phone Number: _____

Email: _____

Email: _____

Authorized Distributors

East Coast Microwave

70 Tower Office Park

Woburn, Massachusetts 01801

www.ecmstockroom.com/products/search?q=Corning

1-781-279-0900 (International)

1-800-786-2576 (United States and Canada)

sales@ecmstockroom.com

Microwave Components

3171 SE Dominica Terrace

Stuart, Florida 34997

www.microwavecomponentsinc.com

1-772-286-4455 (International)

800-282-4771 (United States and Canada)

admin@microwavecomponentsinc.com



CORNING

Corning Optical Communications LLC • PO Box 489 • Hickory, NC 28603-0489 USA
800-743-2675 • FAX: 828-325-5060 • International: +1-828-901-5000 • www.corning.com/opcomm

Corning Optical Communications reserves the right to improve, enhance, and modify the features and specifications of Corning Optical Communications products without prior notification. A complete listing of the trademarks of Corning Optical Communications is available at www.corning.com/opcomm/trademarks. All other trademarks are the properties of their respective owners. Corning Optical Communications is ISO 9001 certified. © 2018 Corning Optical Communications. All rights reserved. CRR-721-AEN / April 2018